

ORION

冷熱と真空でイノベーション
Innovating with Thermal Control and Vacuum

Chiller Unit without Water Tank

RKS Series

Cooling Capacity :
0.59/0.62 kW to 4.30/4.65 kW



RKL Series

Cooling Capacity :
7.9/8.5 kW to 25.0/27.1 kW



ORION UNIT COOLER

Adopted stainless steel coil type heat exchanger which is hard to clog

Feb.2021

D-RG12E

Chiller Unit without Water Tank Catalog

Striving to Make Products that Move You

Unit Cooler Series Configurations

ORION Unit Coolers have built-in circulation pumps, so by simply connecting to an open-type water tank and priming with water, tank water can be circulated and maintained at a set temperature.

RKS Series

Compact Unit Cooler



	Model	Power Supply	Cooling Capacity (kW)	Operable Ambient Temp (°C)	Operable Liquid Temp Range (°C)	Req. Water Tank Capacity (L)
Compact, Air Cooled	RKS250F1-S	Single-Phase 100 V	0.59 / 0.62	5 to 40	5 to 25	10 or more
	RKS400F-S		0.89 / 1.02			20 or more
	RKS400F1	Three-Phase 200 V	1.3 / 1.4			25 or more
	RKS500F		2.0 / 2.2			35 or more
	RKS750F		4.30 / 4.65			60 or more
	RKS1500F		1.98 / 2.21			35 or more
Compact, Water Cooled	RKS750F-W					

* The RKS1500F model can be used with three-phase 200 V at 50/60 Hz, or three-phase 220 V at 60 Hz.

RKL Series

Heavy Duty Unit Cooler



	Model	Power Supply	Cooling Capacity (kW)	Operable Ambient Temp (°C)	Operable Liquid Temp Range (°C)	Req. Water Tank Capacity (L)
Heavy Duty, Air Cooled	RKL-2200-D	Three-Phase 200 V	7.9 / 8.5	5 to 43	5 to 30	200 or more
	RKL-3750-D		11.6 / 12.2			300 or more
	RKL-5500-D		18.7 / 20.3			450 or more
	RKL-7500-D		25.0 / 27.1			600 or more

* All models can be used with three-phase 200 V at 50/60 Hz, or three-phase 220 V at 60 Hz.

Here are Just Some Examples of Applications for the ORION Unit Cooler

Application Example (For illustration purposes)

Industrial Applications

- Temperature Management for Cooling Tanks on Extrusion Machines
- Machine Tool Tank-Water Cooling
- Water for Concrete Production

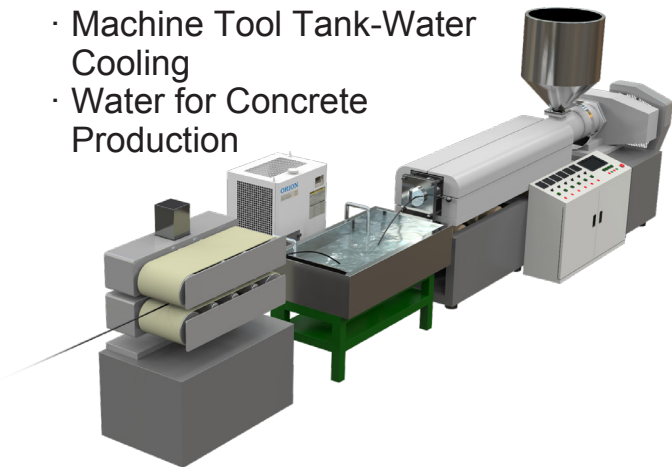

Food Applications

- Cooling After Vacuum Packing
- Canned Food Cooling
- Food Container Cooling

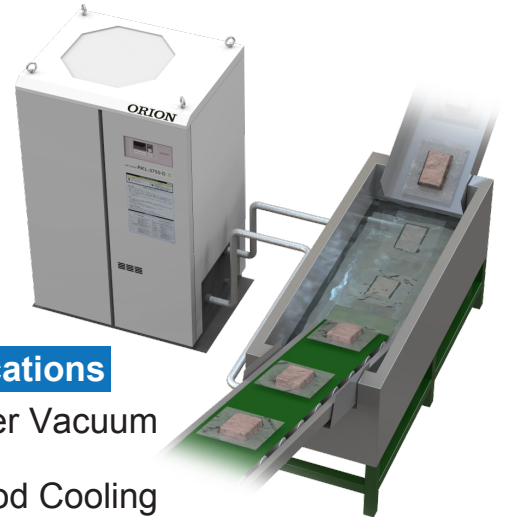

Health Care Applications

- Water Bath Temperature Control



Agriculture Applications

- Liquid Fertilizer Temp. Management for Hydroponics
- Water Tank Cooling for Shiitake Mushroom Log Cover-Water



Other

- Water Cooling for Various Open Tank Applications



RKS Series

Unit Cooler RKS Series

Cooling Capacity: 0.59/0.62 kW
to 4.30/4.65 kW

Built-In Circulation Pump	Digital Temperature Control	External Signal Terminals	Condenser Filter Included (except RKS750F-W)	Rated for 3 Power Sources (RKS1500F)	Multi-Directional Vent (RKS1500F)	HFC Refrigerant R407C (except RKS250F1-S) (except RKS400F1)	High Efficiency Refrigerant R410A (RKS400F1)	HFC Refrigerant R-134a (RKS250F1-S)
---------------------------	-----------------------------	---------------------------	---	---	--------------------------------------	---	---	--

Features

1. Built with a heat exchanging coil that inhibits clogging and can be disassembled when required.

Chillers that use external water tanks are susceptible to foreign substances entering the system.

With Orion's distinctive heat exchange coil system, there is less likelihood of clogging and yet, in the unlikely chance that clogging does occur, the coil can be disassembled for cleaning.

2. Connections and controls are focused onto the front panel for improved ease of use.

Installation layout has been greatly improved with the control switch, temperature display, water IN and OUT piping, and drain port, all concentrated onto the front panel.

3. Works well in space saving, low profile environments.

The height of the chiller has been lowered as much as possible allowing convenient placement in most site layouts.



RKS750F



RKS1500F

Specifications

Item	Model	Air Cooled						Water Cooled	
		RKS250F1-S	RKS400F-S	RKS400F1	RKS500F	RKS750F	RKS1500F	RKS750F-W	
Performance Specifications	Cooling Capacity (50/60Hz) *1,2	kW	0.59 / 0.62	0.89 / 1.02		1.30 / 1.40	2.00 / 2.20	4.30 / 4.65	1.98 / 2.21
	Operable Ambient Temperature Range	°C	5 to 40						
	Operable Liquid Temperature Range	°C	5 to 25						
Power Specifications	Power Source	V(Hz)	Single - phase 100 ± 10% (50/60)		Three - phase 200 ± 10% (50/60)		Three - phase 200 ± 10% (50/60) 220 ± 10% (60)	Three - phase 200 ± 10% (50/60)	
	Power Consumption (50/60Hz) *2	kW	0.34 / 0.39	0.42 / 0.49	0.45 / 0.50	0.72 / 0.85	0.85 / 1.05	1.6 / 2.1, 2.1 *5	0.73 / 0.89
	Electric Current (50/60Hz) *2	A	4.3 / 4.0	4.8 / 5.1	1.85 / 1.75	3.0 / 2.8	3.2 / 3.6	6.0 / 7.0, 6.9 *5	2.7 / 3.0
	Power Capacity	kVA	0.6	0.7	0.8	1.3	1.6	3.5	1.2
	Breaker Capacity	A	10		5		10	15	5
Equipment Details	Compressor Output	kW	0.4	0.3	0.5	0.6	0.65	1.4	0.65
	Condenser		Fin and tube forced air cooling						Double pipe water cooling
	Heat Exchanger	Construction	Shell and coil						
		Materials	Shell: ABS Coil: SUS304				Shell: PBT Coil: SUS304		Shell: ABS Coil: SUS304
	Circulation Pump (50/60Hz)	Output	W	20			45	105 / 150	45
		Circulation Rate	L/min	15 to 24 / 15 to 27			20 to 27 / 20 to 30	30 to 50 / 30 to 60	20 to 27 / 20 to 30
	Fan Motor Output *3	W	10			25	100	-	
	Refrigerant		R-134a	R-407C	R-410A	R-407C			
	Charged Amount	kg	0.23	0.28	0.3	0.28	0.36	0.95	0.33
	External Dimensions (H×D×W)	mm	283×375×454	295×375×454		333×375×484	398×405×534	600×500×650	398×405×534
Unit Mass (dry weight)	kg	Approx. 25	Approx. 30		Approx. 35	Approx. 43	Approx. 70	Approx. 45	
Operating Noise Level (50/60Hz) *4	dB	53 / 57			55 / 59		57 / 59	51 / 55	
Required Water Tank Capacity	L	10 or more	20 or more		25 or more	35 or more	60 or more	35 or more	

*1 Cooling capacity is at least 95% of listed figures. *2 When liquid temperature is 20°C and ambient temperature is 32°C. *3 Fan motor static pressure is 20Pa.

*4 Operating noise levels are from a position of 1m in front of the unit and at a height of 1m. *5 At 200V 50/60Hz or 220V 60Hz.

Note 1: The recommended liquid (chilled water) that can be used is either clean water or a 30-40% industrial-use ethylene glycol solution. Alternatively, if deionized water is used, it should have an electrical conductivity of at least 1 μS/cm.

Note 2: Heat output of the equipment (in kW) is about 1.3 times the cooling capacity. (air cooled models only) Note 3: RKS750F-W is a built to order item.

Cooling Capacity

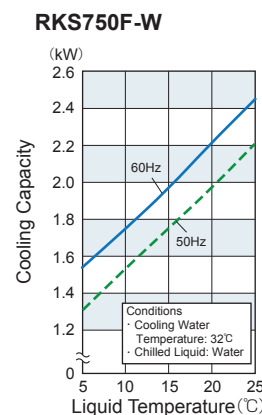
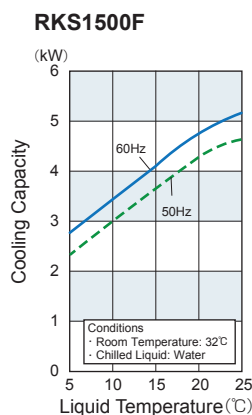
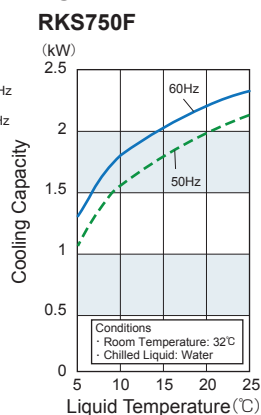
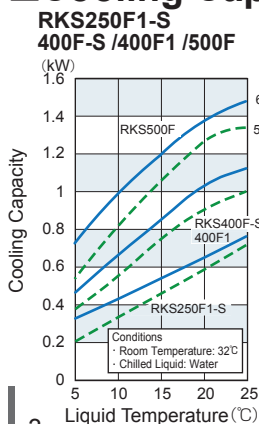

Cooling Water Flow Rate (for condenser)

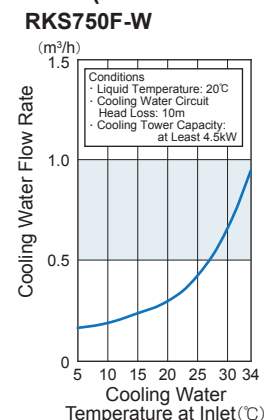

RKL Series

Unit Cooler RKL Series

Cooling Capacity: 7.9/8.5 kW
to 25.0/27.1 kW

Built-In
Circulation
Pump

Digital
Temperature
Control

External
Signal
Terminals

Condenser
Filter
Included

Rated for
3 Power
Sources

IPX3 Equiv.
Rating
Splash-proof

HFC
Refrigerant
R407C

Features

1. Built with a heat exchanging coil that inhibits clogging and can be disassembled when required.

Chillers that use external water tanks are susceptible to foreign substances entering the system.

With Orion's distinctive heat exchange coil system, there is less likelihood of clogging and yet, in the unlikely chance that clogging does occur, the coil can be removed for cleaning.

2. Space saving design is perfect for space conscious layouts.

Slim vertical design. The unit can be placed with the back side against the wall.

3. Wide-Ranging Liquid Temperature Setting

Wide temperature setting range of 5°C to 30°C.
Original, easy-to-set temperature controller.



RKL-3750-D

Specifications

Item	Model	Air Cooled				
		RKL-2200-D	RKL-3750-D	RKL-5500-D	RKL-7500-D	
Performance Specifications	Cooling Capacity (50/60Hz) * 1,2	kW	7.9 / 8.5	11.6 / 12.2	18.7 / 20.3	25.0 / 27.1
	Operable Ambient Temperature Range	°C	5 to 43			
	Operable Liquid Temperature Range	°C	5 to 30			
Power Specifications	Power Source	V(Hz)	Three - phase 200 ± 10% (50/60)、220 ± 10% (60)			
	Power Consumption (50/60Hz) * 2,5	kW	3 / 4, 4	5 / 6, 6	7 / 8, 8	10 / 12, 12
	Electric Current (50/60Hz) * 2,5	A	11 / 13, 13	18 / 20, 20	24 / 27, 27	33 / 37, 37
	Power Capacity * 3	kVA	5.5	8.3	11.8	18.7
	Breaker Capacity	A	20	30	40	60
Equipment Details	Compressor Output	kW	2.24	3.73	5.22	7.46
	Condenser		Fin and tube forced air cooling			
	Heat Exchanger	Construction	Shell and coil			
		Material	Shell: SUS304, Coil: SUS304 grade stainless steel			
	Circulation Pump (50/60Hz)	Output	L/min	150 / 180	400	750
		Circulation Rate	W	40 to 60 / 40 to 70	70 to 115 / 70 to 130	80 to 120 / 80 to 140
	Fan Motor Output * 3		100 (inverter driven)	200 (inverter driven)	750 (inverter driven)	
	Refrigerant		R-407C			
	Charged Amount	kg	1.7	2.35	4.6	5.7
	External Dimensions (H×D×W)	mm	1400×677×860	1445×705×1025	1740×815×1287	
Unit Mass	kg	Approx. 195	Approx. 255	Approx. 405	Approx. 430	
Operating Noise Level (50/60Hz) * 4	dB	59 / 61	61 / 64	64 / 67	65 / 68	
Required Water Tank Capacity	L	200 or more	300 or more	450 or more	600 or more	

* 1 Cooling capacity is at least 95% of listed figures. * 2 When liquid temperature is 20°C and ambient temperature is 32°C. * 3 Fan motor static pressure is 20Pa.
* 4 Operating noise levels are from a position of 1m in front of the unit and at a height of 1m. * 5 Values indicated are at: 200 V at 50/60 Hz, 220 V at 60 Hz.
Note 1: The recommended liquid (chilled water) that can be used is either clean water or a 30-40 % industrial-use ethylene glycol solution. Alternatively, if deionized water is used, it should have an electrical conductivity of at least 1 μS/cm.
Note 2: Heat output of the equipment (in kW) is about 1.3 times the cooling capacity.

Cooling Capacity

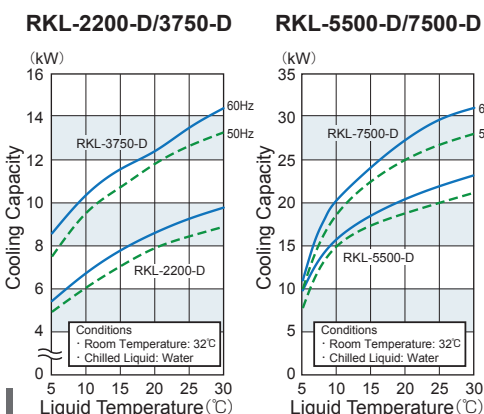

Pump Characteristic Curves

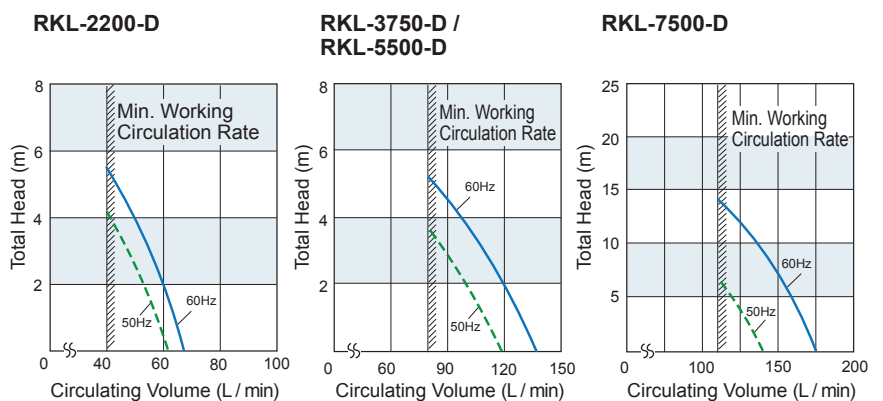

External dimensions (Units: mm)

RKL-2200-D

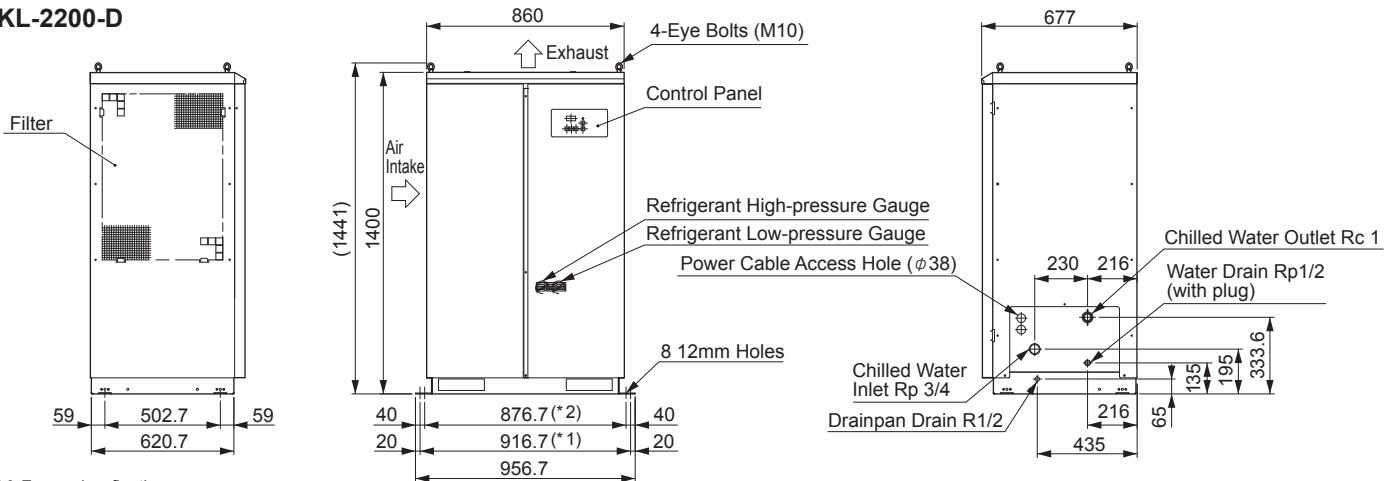

*1 For anchor fixation

*2 RKL-2200-B1 hole pitch sizes are compatible with this chiller. When upgrading from RKL-2200-B1, please use the pitch sizes listed here.

RKL-3750-D

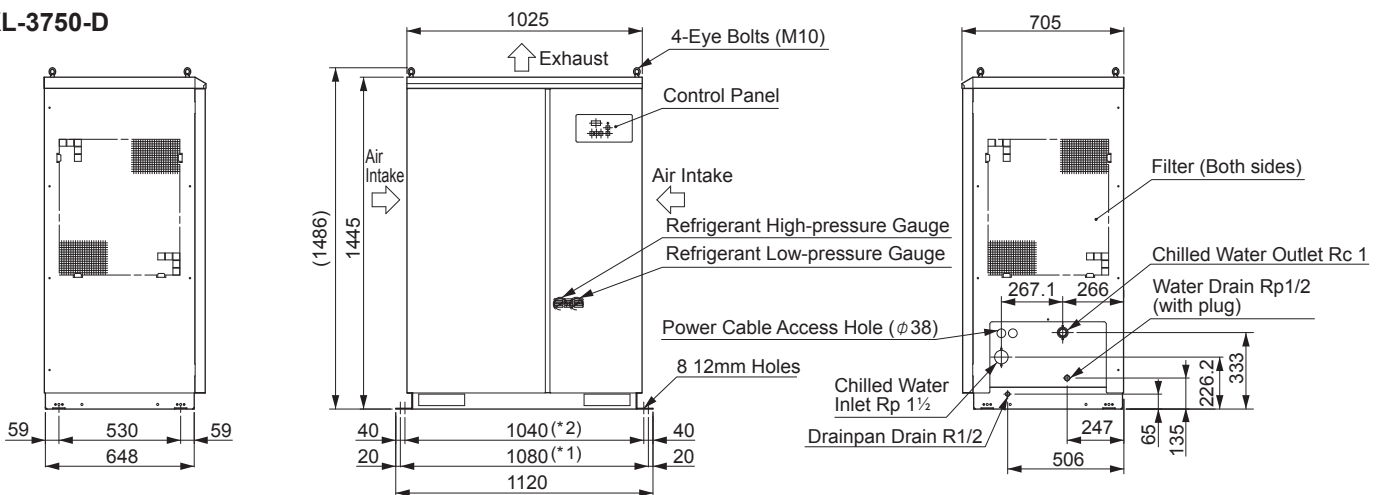

*1 For anchor fixation

*2 RKL-3750-B1 hole pitch sizes are compatible with this chiller. When upgrading from RKL-3750-B1, please use the pitch sizes listed here.

RKL-5500-D / RKL-7500-D

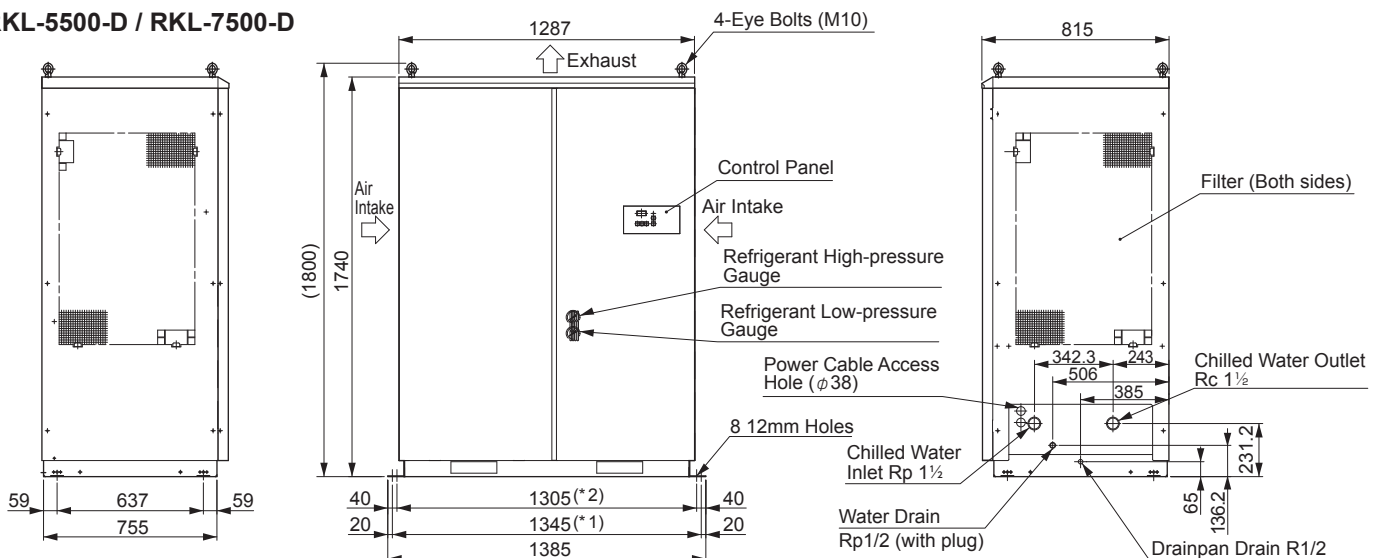

*1 For anchor fixation

*2 RKL-5500-B1 and 7500-B1 hole pitch sizes are compatible with this chiller. When upgrading from RKL-5500-B1 and 7500-B1, please use the pitch sizes listed here.

Introducing the ORION IoT System / Unit Cooler Specification Items

Remote Monitoring

of ORION Products.

Uses your factory's internal network for safety against leaks of internal information.

Compatible Models

RKL Series

Monitoring

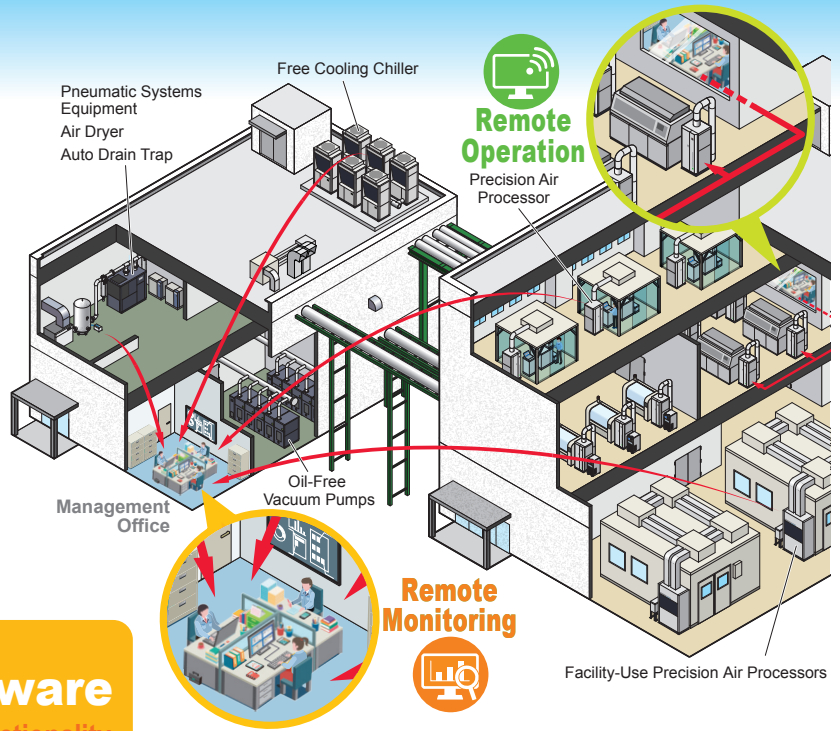

Contact-State Monitoring Software
Includes Mail-Alert Functionality

Monitoring of product operating states from remote sites is possible. Can be used as long as contact outputs are **non-voltage contacts**. Get email alerts when alarms occur! Getting alerts while away from the PC gives peace of mind!

Need to walk to the site every day in order to check the operating state of your equipment...
And the constant worry that you won't be around when an alarm condition occurs!

Checking operating states is easy! Mail alerts for alarm conditions give peace-of-mind when away from the site.

How to Download our IoT Software

STEP 1	STEP 2	STEP 3
Visit our website. 	Confirm the download you need from the list of software.	Perform the registration process and enter the product model number and serial number.

Note that our software is only offered in Japanese. Operation with non-Japanese operating systems has not been confirmed. Please refer to the instruction manual for required equipment and specifications.

Unit Cooler Specification Items

* The number and type of functions differ according to the model. Please refer to the specifications of individual models for further details.

Built-In Circulation Pump	Built-in circulation pump takes in and discharges chilled water (in open loop configurations.)	Digital Temperature Control	Easy operation and setting of liquid temperature is possible with Orion's distinctive temperature control system. Furthermore, in the unlikely event that some trouble does occur, the root of the problem can be understood with just a glance of the error display code.
IPX3 Equip. Rating Splash-proof	Outdoor installation is possible under a roof as long as there is no direct contact with rain, in accordance with the IPX3 (JIS C 0920) standard. * Installation in direct sunlight, strong wind (8 m/sec or higher), contact with falling snow, or freezing conditions requires further measures. An IPX3 rating refers to the amount and nature of water exposure equipment can withstand. Specifically, it indicates that "equipment can safely withstand water exposure at any angle from the perpendicular to within 60° at an intensity of about 10 L/min or less."	External Signal Terminals	Terminals are provided for an operation signal, warning signal, and remote operation.
High Efficiency Refrigerant R410A	R410A is a new refrigerant that is highly efficient and does not contribute to the destruction of the ozone.	Rated for 3 Power Sources	Works with the following power sources: three phase 200V at 50 or 60Hz, or three - phase 220V at 60Hz.
HFC Refrigerant R407C	This equipment is adopted for use with R407C refrigerant which does not contribute to the destruction of the ozone.	Multi-Directional Vent	Hot ventilation exhaust can be directed as needed to better suite your working environment.
HFC Refrigerant R-134a	Uses non-ozone-depleting R-134a refrigerant.	Condenser Filter Included	Comes with a condenser intake filter built-in for easy maintenance in environments that have lots of dust and dirt.

Unit Cooler Special-Order Specifications and Optional Parts List

○ : Optional equipment ● : Available by Special Order
 × : Not compatible Standard : Standard configuration

Note: Please be aware that specifications on this chart are subject to change without notice.

No.	Requirements Specification Options				Applicable Model		
	Requirement 1	Requirement 2	Requirement 3	Requirement 4	RKS (no water tank)	RKL (no water tank)	
1	Cooling liquid replacement	Deionized water (up to 1 μ S/cm)	Wetted parts are copper-free *1, *13		●	Standard	
2	Operable liquid temperature range	High liquid temperature	10 to 30℃		●	Standard	
3	Power source (Using an autotransformer) *3 *4	380V 50 / 60Hz			● (external)	● (external)	
		400V 50 / 60Hz			● (external)	● (external)	
		415V 50 / 60Hz			● (external)	● (external)	
		440V 50 / 60Hz			● (external)	● (external)	
		480V 50 / 60Hz			● (external)	● (external)	
4	Pump specifications *1	Pump pressure (at pump outlet) ~0.1MPa	Flow rate (at required pressure) Within specified range		Standard	Standard	
			Over specified range		●	●	
5	Casters *5	With stopper	2 swivel casters		●	●	
			4 swivel casters		●	○	
		With leveling foot	2 swivel casters		●	×	
			4 swivel casters		●	○	
6	Custom coating (Regarding color, specify JFMA No. or Munsell No. from sample chart)		15 μm min.		●	●	
			30 μm min. *6		●	●	
			45 μm min. (salt-air protection) *7, *8		●	●	
7	Installation environment	Indoors			Standard	Standard	
		IP-X3 equiv.			●	Standard	
		IP-X4 equiv.			×	●	
		Packaging for export *9			●	●	
		Clean room *10			●	●	
8	External signal	Operation signal	No-voltage contacts		Standard	Standard	
			Voltage output (200V)		●	●	
		Warning signal	No-voltage contacts		Standard	Standard	
			Voltage output (200V)		●	●	
		Remote operation (alternate (continuous) input only)	No-voltage contact input	Extension length	max. 20m	Standard	Standard
			Voltage input (DC24V)		max. 100m	●	●
Voltage input (AC200V)	max. 20m		●		●		
9	Blackout, power-cut-off recovery operation	Manual recovery			Standard	Standard	
		Automatic recovery			●	●	
10	Circuit breaker	Leakage breaker			●	●	
		Over current breaker			●	●	
11	Piping fixtures	Chilled water outlet/return ports	With gate valve	Specify size	●	●	
		Cooling water inlet/outlet ports (Water cooled models)	With gate valve	Specify size	●	×	
12	Temperature Precision	±0.5℃			×	● *11	
		±1.0℃			● (HB control) *12	● *11	
		±2.0℃			Standard	Standard	
13	Display language	English			●	●	
		Japanese and English			●	●	
14	Leak detector installation				●	●	
15	With anchor bolts	Stainless steel or steel			●	●	
16	Multi-Directional Vent	User installed			○ *2	×	
17	Test manual	Japanese			●	●	
		English			●	●	
18	Test results chart	Japanese			●	●	
		English			●	●	
19	Initial inspection				●	●	
20	With eyebolts				×	Standard	

*1 : Cooling capacity reduced only by the amount of heat generated by the pump.

*2 : Comes standard on RKS1500F models.

*3 : Not equipped with eye bolts, so must be moved by forklift.

*4 : IPX that meets the product specifications.

*5 : RKL5500-D and RKL7500-D models shipped by a charter truck in Japan.

*6 : External screws are SUS.

*7 : External screws are SUS, and the condenser and refrigerant piping are coated with polyurethane.

*8 : Refrigerant piping is coated, but this coating is not guaranteed.

*9 : Crated in plywood.

*10 : These models are equipped with a leakage sensor, pressure resistant piping, insulated refrigeration piping, and insulated water piping. (Particulate not taken into consideration.)

*11 : Available with non-water-tank RKE models.

*12 : RKS750 and RKS1500 models are available with non-water-tank RKE models.

*13 : Copper alloy is used for wetted parts on standard units.

Connection Methods and Model Choice

(Unit Cooler Series)

Unit Cooler Connection Examples

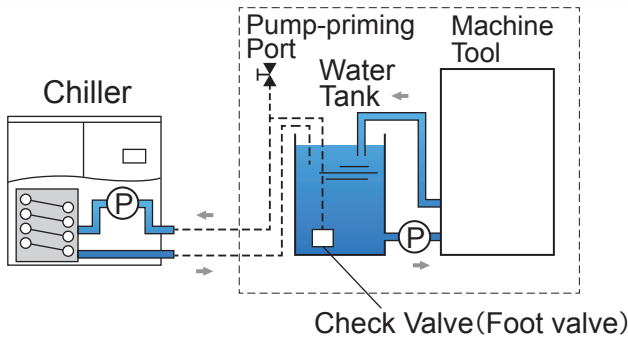

Working Principles

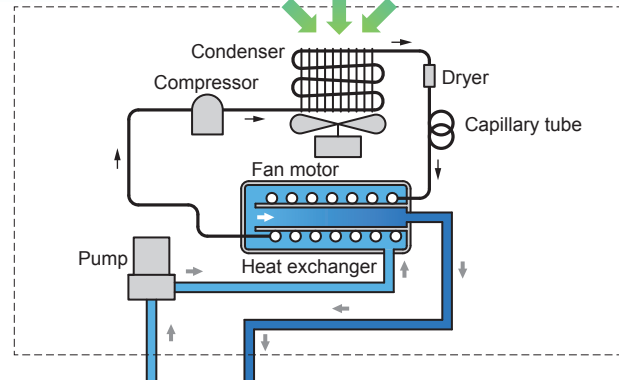

The circulation pump pumps in liquid from the water tank and then through the heat exchanger. There, the liquid is cooled and then returns to the tank. This cycle is repeated and the liquid is continuously cooled until it reaches the desired set temperature, at which time the temperature regulator shuts off the chiller. And if the liquid temperature rises above the set control value, the chiller is automatically started again. Thus, the temperature is maintained, and maintenance costs remain low.

* Provide a separate water tank when using a Unit Cooler. In such cases, the water tank must have a capacity based on the model of Unit Cooler used. Please refer to individual model specifications for further details.

Making the right model choice

1. Sample cooler heat calculation and model selection methods are listed below.

Please make a model choice that best suits your operating conditions and requirements.

- ① Find the cooling capacity required to deal with heat generated by a piece of equipment which is to be cooled by a chilled water flow; the temperature difference between the cooling water going into and out of the equipment is known.

The equipment to be cooled is accepting a cooling water flow of 12 L/min, the water temperature going into the equipment is 17°C, and the temperature of the water coming out is 20°C. What is the amount of heat being generated by this equipment?

$$Q = \frac{(t_2 - t_1) \times (X \times 60) \times C \times \rho}{860} = \frac{(20 - 17) \times (12 \times 60) \times 1 \times 1}{860} = 2.51 \text{ kW}$$

Considering 20% as a safety factor : $2.51 \times 1.2 = 3.01 \text{ kW}$

- ② In case a certain temperature drop is required in a fixed amount of time.

For example, if 40L of 20°C water is in a separate tank, what is the heat dissipation required to lower the temperature of the water to 5°C in one hour?

$$Q = \frac{W \times C \times (t_2 - t_1)}{H \times 860} = \frac{40 \times 1 \times (20 - 5)}{1 \times 860} = 0.7 \text{ kW}$$

Note: When making a model selection, also consider heat from external sources that might raise the temperature of the water in the water tank. In order to compensate for such external heat sources, it is recommended that an additional 20% in cooling capacity be added to the power calculation.

$$Q = 0.7 \times 1.2 = 0.84 \text{ kW}$$

Q : Amount of heat in kW
(1kW = 860kcal/h)

W : Weight of cooling liquid
(volume x specific gravity)

C : Relative heat in kcal/kg°C
(in case of water: 1)

t₂ : Upper temperature (°C)
t₁ : Lower temperature (°C)

H : Required cooling time in hours

P : Power from an electric heater
running 1 hour in kW

X : Water flow per minute: L/min

ρ : Density kg/L (1 for water)

2. Piping Resistance Calculations

Piping methods and other particulars have a large effect on the flow rate, head, and resistance of the water cycle. Furthermore, safety devices may also be operating, so it is important to install a piping design that can keep within the prescribed piping resistance (head) limitations.

The following describes how to calculate the head of a system.

$$H_m = h_a + h_v + h_f + h_t < HL$$

H_m = Total head

- h_a = actual head (the difference in height between the water surface and the chiller)
- h_v = velocity head delta (water resistance from the outlet ... generally about 0.5m~0.8m.)
- h_f = piping head loss {head loss due to water resistance within the piping ... in meters (m)}
- h_t = sectional head loss {resistance due to curved pipe sections ... in meters (m)}
- HL = head limit (Value may differ for models without water tanks. Value may differ for models with built-in water tanks depending on model of discharge pump used.)

■ The choice of Unit Cooler (pump) should be based on the pump characteristic curves as well as the head and circulation load, allowing for sufficient leeway.

Example 1: How to find h_f

What is the head loss in a piping system where the inside diameter of the piping is 20mm, the equivalent length is 20m, and the water flow is 50 L/min?

- 50 L/min = 0.05 m³/min. According to the chart below, the head loss at this value is 40m per 100 meters of piping, which comes to a head loss of 0.40m per meter of piping. So the actual head loss for 20m of such piping is 0.4 × 20 = 8.0m.

Example 2: How to find h_t

What is the head loss for a 20mm I.D. elbow section with a water flow of 50 L/min?

- First, find the equivalent length of the elbow pipe. Make a straight line from the point of the standard elbow on the ① line below to the 20mm point on the ③ line. The point where this line intersects line ② indicates the equivalent length of the elbow section.

According to the chart below, the equivalent length of the pipe is 0.6m.

- In Example 1 it was determined that a 1m section at 50 L/min yields a head loss of 0.40m. So it follows that the head loss for the elbow section with would be: 0.6 × 0.40 = 0.24m.

Head Loss within Hard PVC Pipe

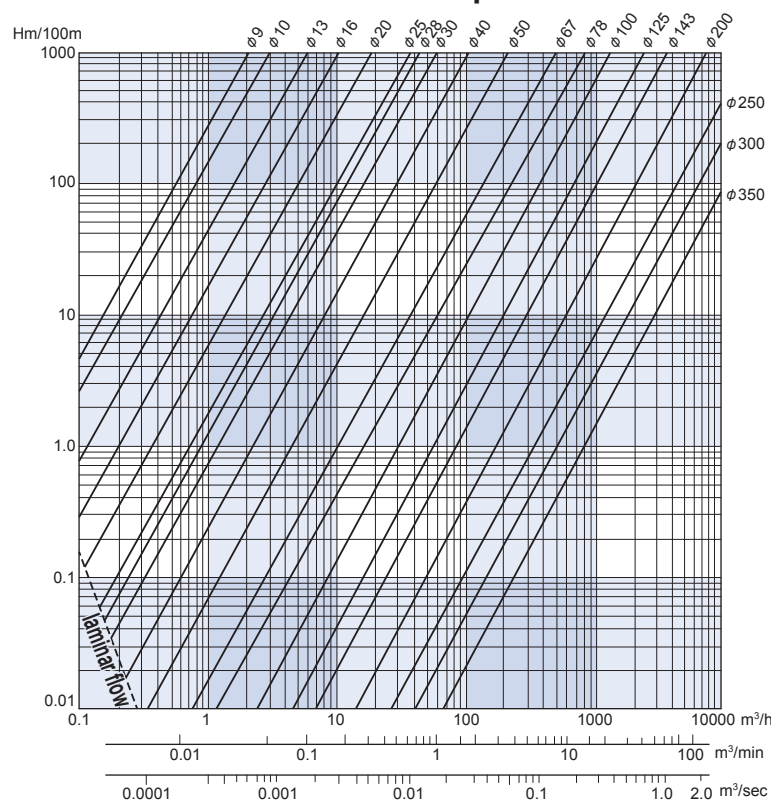

Equivalent Lengths for Valves and Couplings

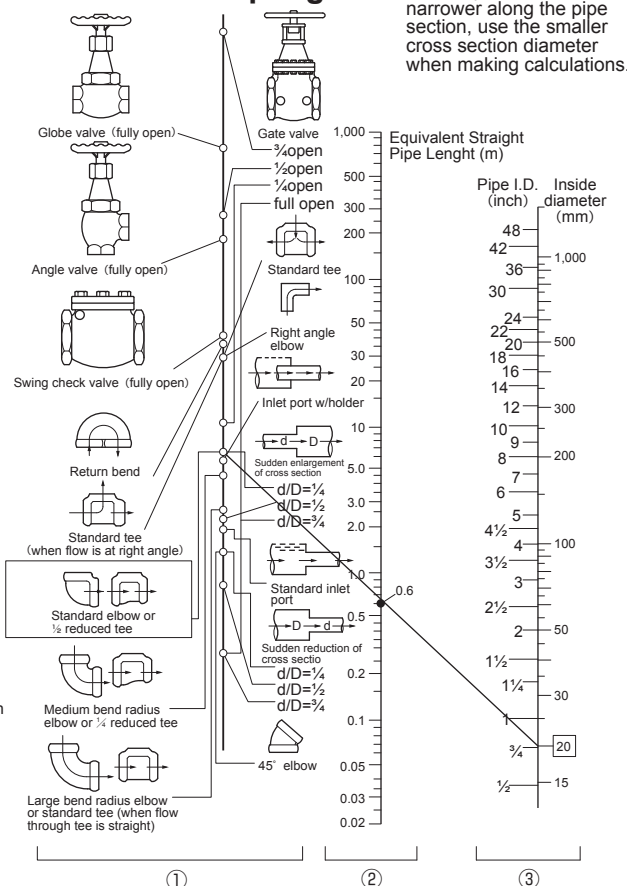

Note: In cases where the cross section becomes suddenly wider or narrower along the pipe section, use the smaller cross section diameter when making calculations.

Please read before adopting this equipment or making a model choice.

Please read and carefully follow the safety precautions listed herein to ensure safe and proper use of this equipment for the protection and prevention of loss to you, the surrounding area, and people nearby.



Failure to follow instructions contained in these WARNINGS may result in death or serious injury.

Working Environment (Installation environment)



Product Use Limitations

- (1) If the unit is to be used as part of critical installations, safety devices and backup systems which can be switched to should be put into place to insure that serious accidents or losses do not occur in the event that the unit should break down or malfunction.
- (2) This product was designed and produced as a general purpose device for use in ordinary manufacturing. Accordingly, the warranty does not apply to nor cover the following applications. However, in cases where the customer/user takes full responsibility and confirms the performance of the equipment in advance, and takes necessary safety precautions, please consult with ORION and we will consider if use of the unit in the desired application is appropriate.
 - ① Atomic energy, aviation, aerospace, railway works, shipping, vehicles (cars and trucks), medical applications, transportation/communications applications, and/or any applications where it might have a great affect on human life or property.
 - ② Electricity, gas, or water supply systems, etc. where high levels of reliability and safety are demanded.



Please install this equipment in a place that is level, free from vibration, and one that can fully support the weight of the equipment. Always take measures to ensure the unit will not tip over.

Not properly installing the equipment as indicated can result in water leaks, and injury from tipping over, or falling, etc.



Never install in places where flammable gases may be present or where leakage of such flammable gases may occur.

If by some chance such gas were to leak and collect near this equipment, a fire could break out.



Never use this equipment in the presence of corrosive gases.

Corrosion can lead to electric shock or refrigerant leaks.

Installation



Please arrange for installation by your dealer or other qualified persons.

Installation undertaken by unqualified or inexperienced persons may result in improper installation, which can lead to water leakage, electric shock, or fire.



Be certain that all electrical wiring is done in accordance with relevant electrical construction and wiring regulations, and use only prescribed cables.

Installation with an insufficient power supply or improper installation can result in electric shock or fire. Improperly securing cables to electrical contacts can lead to electric shock, overheating, or fire.



When lifting this equipment via the suspension eyebolts, always use all 4 suspension eyebolts and ensure the angle of the suspension cable at the eyebolts is at least 60.

Improper suspension may lead to the equipment tipping over or falling, which may lead to injury. The RKS1500F can be suspended using two suspension points.



Always install and use this equipment with an earth leakage breaker.

Using the equipment without an earth leakage breaker can lead to electric shock.



Ensure that the equipment is properly grounded. (Installation of a proper ground hookup must be performed by a qualified electrician.)

Improper grounding of this equipment can lead to electric shock.

Control and Operation



Operation of this equipment should be carried out by persons who are knowledgeable and experienced in its operation, including related equipment, and all relevant safety guidelines.







CAUTIONS

Failure to follow instructions contained in these CAUTIONS may result in personal injury or damage to property.

Working Environment (Installation environment)

-  **Do not install this equipment in places of the following environments:**
 - ①Exposure to direct sunlight.
 - ②Where there is a chance of freezing.
 - ③Places with high concentrations of dirt, dust, or oil mist.
 - ④Where the equipment might be exposed to rain water or other liquids.
 - ⑤Where the ambient temperature is beyond the specified operating ambient temperature of the equipment.
 - ⑥Where the surrounding humidity is outside the 25 ~ 85% range.
 - ⑦In places without adequate drainage. (An exception can be made in cases where the unit can be moved to a place where it can be drained.)
- * If the equipment is not properly installed, burst water pipes, leaks, considerable operation degradation, or breakdown can occur.

Installation

-  **Never stand on the unit. Never place anything on the unit when it is running.**
-  **Source power supply to the unit should be within $\pm 10\%$ of the specified supply voltage, and phase unbalance should be less than $\pm 3\%$.**
-  **Use piping of a material that will not rust, and install the included foot valve and strainer in order to prevent against the intake of foreign matter.**
-  **Ensure that wetted surfaces that come into contact with the chilled water are not aluminum.**
Aluminum corrosion can lead to blockage within the water circuit and could lead to breakdown, so if aluminum must be used, please consult your dealer first.
-  **Install piping such that the weight of the piping is adequately distributed and supported via brackets, and is not being supported by the equipment to which it is attached.**
-  **Do not install drain piping with vertical rises.**

-  **Do not operate the circulation pump dry.**

-  **Regarding water-cooled Unit Coolers, if using water other than tap water as cooling water for the water-cooled condenser, please use water that meets the water quality standard shown on the right. ***

(Do not use pure water, treated sewage and softening-treated water.)

* RKS750F-W

-  **Wetted parts within the water cooled condenser that come into contact with cooling water are constructed with iron piping. ***

There is a chance that iron rust can occur. If this becomes a problem, please consult your dealer.

* RKS750F-W

-  **Note that there is no drain pan built into the component area of this product, and drain may flow outside the product depending on operating conditions. ***

Please let us know if a drain pan built into the bottom of the product is required.

* RKS Series

Standard Concentration Levels for Cooling Water used in Water Cooled Condensers

Item	Cooling Water Type		Has Tendency Towards:	
	Circulation water	Make-up Water	Corrosion	Scaling
pH (25°C)	6.5 - 8.2	6.0 - 8.0	○	○
Electrical Conductivity ($\mu\text{S}/\text{cm}$) (25°C)	Max. 800	Max. 300	○	○
Chloride Ion (mgCl^-/L)	Max. 200	Max. 50	○	
Sulphate ($\text{mgSO}_4^{2-}/\text{L}$)	Max. 200	Max. 50	○	
Acid Consumption (pH4.8) (mgCaCO_3/L)	Max. 100	Max. 50		○
Total Hardness (mgCaCO_3/L)	Max. 200	Max. 70		○
Calcium Hardness (mgCaCO_3/L)	Max. 150	Max. 50		○
Silica Ion (mgSiO_2/L)	Max. 50	Max. 30		○
Iron (mgFe/L)	Max. 1.0	Max. 0.3	○	○
Copper (mgCu/L)	Max. 0.3	Max. 0.1	○	
Sulfide Ion (mgS^{2-}/L)	Not detected	Not detected	○	
Ammonium Ion (mgNH_4^+/L)	Max. 1.0	Max. 0.1	○	
Residual Chlorine (mgCl/L)	Max. 0.3	Max. 0.3	○	
Free Carbon Dioxide (mgCO_2/L)	Max. 4.0	Max. 4.0	○	
Ryznar Stability Index	6.0 - 7.0	—	○	○

Excerpt from JRA-GL-02-1994 of The Japan Refrigeration and Air Conditioning Industry Association

- Within the "Tendency toward" column, items marked with a ○ indicate this component can lead to corrosion or scaling as indicated.
- The 15 items listed above are the primary components that can lead to corrosion or scaling.

! Plan for enough space around the unit to facilitate optimum unit performance as well as a working space for maintenance tasks.

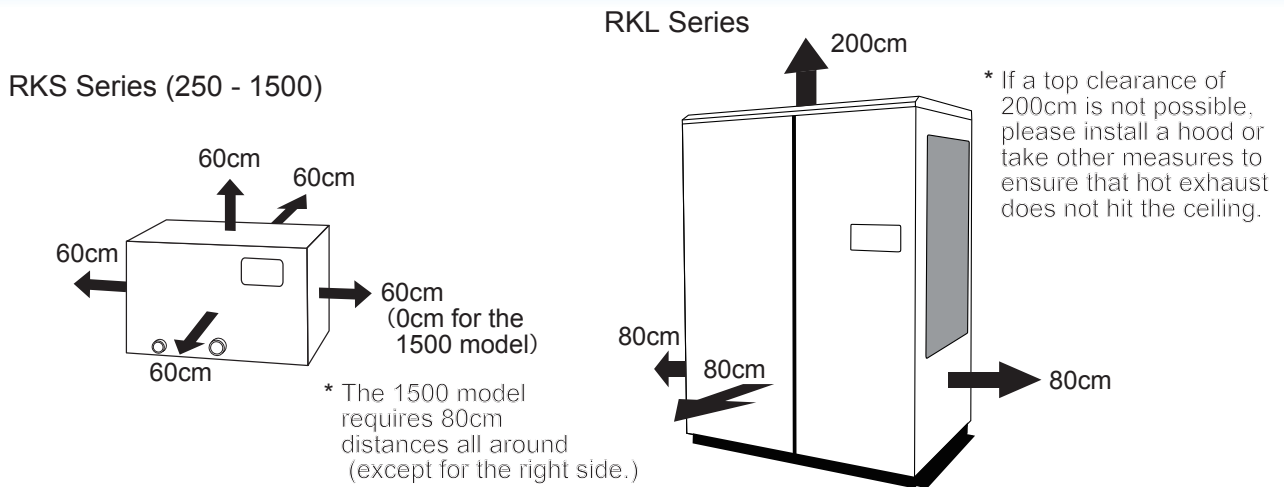

Before Moving the Unit

! Please drain the water from the product before moving. Moving the product while water remains can damage the water piping and cause water leaks.

Standard Operation

! The recommended liquid (chilled water) that can be used is either clean water (see chart below for water quality standard) or a 30 to 40% ethylene glycol solution. Alternatively, if deionized water is to be used, it should have an electrical conductivity of at least 1 $\mu\text{S}/\text{cm}$.

Standard Level	Standard Components							Reference Components						
	pH (25°C)	Electrical Conductivity (25°C) ($\mu\text{S}/\text{cm}$)	Chloride Ion (mgCl^-/L)	Sulphate ($\text{mgSO}_4^{2-}/\text{L}$)	Acid Consumption (pH4.8) (mgCaCO_3/L)	Total Hardness (mgCaCO_3/L)	Calcium Hardness (mgCaCO_3/L)	Silica Ion (mgSiO_2/L)	Iron (mgFe/L)	Copper (mgCu/L)	Sulfide Ion (mgS^{2-}/L)	Ammonium Ion (mgNH_4^+/L)	Residual Chlorine (mgCl/L)	Free Carbon Dioxide (mgCO_2/L)
	6.8 - 8.0	1 - 400	Max. 50	Max. 50	Max. 50	Max. 70	Max. 50	Max. 30	Max. 10	Max. 10	Not detected	Max. 10	Max. 0.3	Max. 4.0

* From JRA GL-02-1994 (water circulation for water cooled systems)

If the quality of water to be used for cooling does not fall within the prescribed guidelines, it may result in corrosion in the circulation or heat exchanger of the equipment, clogging, etc. Please confirm water quality prior to use.

Also, if the chilled water is dirty, corrosion may occur even if the concentration of chloride ion is below 10mgCl/L, so please replace water regularly.

! Please consult your dealer before using any water additives. Troubles such as the water becoming dirty, or damage to the heat exchanger from clogging etc. can result depending on the type of additive used.

! Always apply power to the unit at least 12 hours before conducting initial test runs, or when the unit has been unpowered for over 24 hours.

(Unit Cooler RKL and RKE Series)

Failure to apply power in advance as directed can lead to damage to the refrigeration compressor.

Maintenance Inspection

! Please ensure all safety requirements have been met regarding the main unit as well as all related equipment.

- Every month check that the water is clean, and free of slime, dirt, strange odor, and foreign substances, and perform cleaning at regular fixed intervals.
- Every month inspect the condenser and condenser filter for dirt and perform cleaning at regular fixed intervals.
- For models that have a built-in inverter, clean the inverter cooling fan and fins every 6 months. In addition, the inverter circuitry holds a charge, so do not remove the inverter cover. Doing so may lead to an electric shock.
- Inspect the pump for water leakage every 6 months. Please contact your dealer if there is water leakage.

Built-In Water Tank Chillers Available Light Duty Chillers Lineup

Model		High-Spec Model Inverter control gives improved energy savings and high-precision temperature control.					Mid-Spec Model RKE Economy Models Compact and Precision Temperature Control										Economy Model Compact and Economy	
Series		RKE					RKS-JM						RKS-GM		RKS-J			
Air / Water Cooled		Air cooled			Water cooled		Air cooled						Water cooled		Air cooled			
Model *1		RKE 750A1 -V-G2	RKE 1500B1 -V-G2	RKE 2200B1 -V-G2	RKE 1500B1 -VW-G2	RKE 2200B1 -VW-G2	RKS 401J -MV	RKS 402J -MV	RKS 752J -MV	RKS 753J -MV	RKS 1502J -MV	RKS 1503J -MV	RKS 402J -MVW	RKS 750G -MVW	RKS 1500G -MVW	RKS 753J -V	RKS 1503J -V	
Control Precision	°C	±0.1					±0.1										±2	
Power Source	V(Hz)	Three-phase 200 (50 / 60) 220 (60)					Single-phase 100 (50 / 60)	Single-phase 200 to 230 (50 / 60)			Three-phase 200 (50 / 60) 220 (60)	Single-phase 200 to 230 (50 / 60)	Three-phase 200 (50 / 60) 220 (60)	Single-phase 200 to 230 (50 / 60)	Three-phase 200 (50 / 60) 220 (60)		Three-phase 200 (50 / 60) 220 (60)	
Cooling Capacity*2	kW (50 / 60Hz)	2.9	5.8	9.5	6	10.4	1.3 / 1.5	1.3 / 1.5	2.2 / 2.5	2.2 / 2.5	4.9 / 5.3	4.9 / 5.3	1.3 / 1.5	2.2 / 2.5	4.9 / 5.3	2.2 / 2.5	4.9 / 5.3	
Flow Rate	L/min (50 / 60Hz)	10 Head: 20 / 30 m	12 / 21 Head: 50 m	28 / 43 Head: 50 m	12 / 21 Head: 50 m	28 / 43 Head: 50 m	10 Head: 30 m	10 Head: 30 m	10 Head: 30 m	10 Head: 30 m	18 Head: 60 m	18 Head: 60 m	10 Head: 30 m	10 Head: 20 / 30 m	12 / 21 Head: 50 m	10 Head: 20 / 30 m	12 / 21 Head: 50 m	

*1 G1 spec. also available without casters. *2 For operation on air-cooled machines when the chilled water temperature is 20 °C and the ambient temperature is 32 °C, or for water-cooled machines when the chilled water temperature is 20 °C and the cooling water temperature is 32 °C. Cooling capacity is at least 95% of listed figures.

Heavy Duty Chillers Lineup

Model		Air Cooled							Water Cooled				
		RKE 3750 B-V	RKE 5500 B-V	RKE 7500 B-V	RKE 11000 B1-V	RKE 15000 B-V	RKE 22000 B-V	RKE 30000 B-V	RKE 3750 B-VW	RKE 5500 B-VW	RKE 7500 B-VW	RKE 11000 B1-VW	RKE 15000 B-VW
Cooling Capacity	kW	12.2	20.3	25.0	37.2	48.0	74.4	96.0	14.1	23.4	27.3	43.0	48.0
Control Precision	°C	±0.1 (Energy saving mode: ±2 °C)							±0.1 (Energy saving mode: ±2 °C)				
Power Source	V (Hz)	Three phase 200 to 220 ±10 % (50 / 60)							Three phase 200 ±10 % (50) Three phase 200 to 220 ±10 % (60)				
Flow Rate	L/min	15 to 60	60 to 170		100 to 230		200 to 460		15 to 60	60 to 170		100 to 230	
Operable Ambient Temp.	°C	-20 to 45 (w/ option: -20 to 50)				- 20 to 45			2 to 45 (w/ option: 2 to 50)			2 to 45	
Operable Liquid Temp.	°C	3 to 35 (w/ anti freeze: 0 to 35) *							3 to 35 (w/ anti freeze: 0 to 35) *				

* Please use antifreeze when operating with fluid temperature settings of 0 to 3 °C.

Please See Our Other ORION Chiller Catalogs

We have a wide range of chillers available.

- Light Duty Chiller with Built-In Water Tank
- Heavy Duty Chiller with Built-In Water Tank
- Dual Channel Chiller



Orion Products -- Service and Safety

● Safety Notes

- Before operating this equipment, please read the operating manual carefully, and only use as indicated.
- For installation of this equipment and required wiring, employ a qualified person or consult with your dealer.
- Be sure to select equipment which suits your needs. Do not use this equipment for purposes other than those for which it is intended. Doing so can lead to accidents or equipment breakdown.

● Air-Cooled Models

If the condenser becomes clogged with dust or dirt, heat exchange will be greatly reduced and electricity consumption will increase. This will lead not only to decreased performance, but can also lead to the activation of built-in safety devices, and eventual damage to the equipment. For these reasons, the condenser should be cleaned on a regular basis.

● Water-Cooled Models

In general, water used to cool condensers will be well-water, tap water, or water from a cooling tower. However water of insufficient quality can lead to scaling in cooling pipes resulting in lower levels of heat exchange, increased electricity consumption and lower performance. Therefore water quality should be confirmed on a regular basis.

Regarding After-Service

- For information regarding repair of equipment that has been in operation, please consult your dealer.
- The customer will be responsible for charges incurred for repairs conducted after the warranty period has expired. In cases where equipment function can be improved by certain service procedures, such procedures will be taken at the specific request of the customer.
- Regarding spare parts... "Spare parts" are those which are necessary in order to maintain the function of the product. It is the policy of ORION to maintain a stock of replacement parts for 7 years after production of the product ceases.

Recommended Maintenance Inspections

- Depending on the particular item, extended use can lead to the product becoming dirty or worn, which can lead to decreased performance. In order to realize continued best performance of this equipment, in addition to prescribed customer maintenance, it is also recommended that regular inspections be conducted. (Service and inspection fees apply.) For further information please consult your dealer or contact ORION directly.

Refrigerant Management

Some of the products in this catalog contain HFC refrigerants. Refrigeration technologies that use HFC refrigerants are essential for achieving efficient temperature control, and while such technologies make great contributions toward saving energy, there is also concern of the impact that the accidental release of HFC refrigerants into the atmosphere has on global warming.

When dealing with HFCs, please ensure compliance with laws and regulations and be sure to manage them appropriately for your safety and for the protection of the environment.

●GWP Values of Refrigerants Used in Our Products

Refrigerant	Global Warming Potential (100-year GWP)
R134a	1430
R404A	3920
R407C	1770
R410A	2090
R32	675

* For details about the refrigerant used in specific products, please refer to the product's specification page.

ORION is continuing to develop a complete and trustworthy nationwide network of expedient sales and service -- everywhere, anytime.



*ORION has wide reaching regional service bases in various countries throughout the world. Please consult your ORION dealer for details.



ISO 9001, 14001

ORION Machinery Co., Ltd is an ISO Certified, Quality Management and Environmental Management company.

— What is the ISO certification system?

ISO (International Organization for Standardization) is an established body that stipulates and certifies ISO9001 and ISO14001 directives. ISO9001 stipulates a system of Quality Management that ensures customer satisfaction and trust in a company's products and services it provides. ISO14001 stipulates a system of Environmental Management whereby production and business activities are carried out in an environmentally conscious manner.

For inquiries, please contact the following representative:

Distributed by:

KOBELCO

PT KOBELINDO COMPRESSORS



+62 811 8754 185

www.kobelindo.co.id

ORION MACHINERY CO.,LTD.

International Group 246, Kotaka, Suzaka-shi, Nagano-ken, 382-8502 Japan
TEL +81-(0)26-246-5664 FAX +81-(0)26-246-5022
Email: kokusai@orionkikai.co.jp

Head Office & Factory 246, Kotaka, Suzaka-shi, Nagano-ken, 382-8502 Japan
TEL +81-(0)26-245-1230 FAX +81-(0)26-245-5424
URL: <http://www.orionkikai.co.jp>