

ORION

冷熱と真空でイノベーション
Innovating with Thermal Control and Vacuum

Light Duty Chiller with Built-In Water Tank

Cooling Capacity :
1.3/1.5kW
2.2/2.5kW
4.9/5.3kW



Cooling Capacity :
2.7 ~ 8.7kW (Air cooled)
6.0, 10.4kW (Water cooled)



Cooling Capacity :
2.2/2.5kW
4.9/5.3kW



The ORION 3-series chiller lineup has
the right chiller to meet your
diversified needs

Choose Your ORION Built-In Water Tank Chiller!

Price Performance Position of 3 Series of Chillers

With our 3-Series Lineup, we have the best chiller to balance your needs and budget.

High Initial Cost

Low

Energy-Saving, Precision Control, High-Spec

High-Spec. Model



RKE Series

5 ▶▶ 12P

High Energy Savings and Precision Control ($\pm 0.1^\circ\text{C}$)

Ambient Temp.: $-5 - 43^\circ\text{C}$ (Air Cooled)

$2 - 43^\circ\text{C}$ (Water Cooled)

Operable Temperature Range (Liquid temp.): $5 - 35^\circ\text{C}$

Control: $\pm 0.1^\circ\text{C}$

High Precision Temperature Control

Mid-Grade Model



RKS-GM Series 17 ▶▶ 18P

Ambient Temp.: $5 - 40^\circ\text{C}$
 Operable Temperature Range (Liquid temp.): $5 - 35^\circ\text{C}$
 Control: $\pm 0.1^\circ\text{C}$

RKS-JM Series

13 ▶▶ 16P

RKE Series Economy Models Compact, Low Price, AND High Precision Temp. Control ($\pm 0.1^\circ\text{C}$)

Ambient Temp.: $5 - 45^\circ\text{C}$
 Operable Temperature Range (Liquid temp.): $5 - 40^\circ\text{C}$
 Control: $\pm 0.1^\circ\text{C}$

Economy Model



RKS-J Series

19 ▶▶ 20P

Compact & Economy

Ambient Temp.: $10 - 40^\circ\text{C}$
 Operable Temperature Range (Liquid temp.): $15 - 35^\circ\text{C}$
 Control: $\pm 2^\circ\text{C}$

Built-In Water Tank Chillers (Closed-Loop System)

ORION Built-In Water Tank Chillers have water tanks and discharge pumps built-in! Closed-Loop Operation eliminates piping and evaporator installation requirements for simplified installation and space-savings.

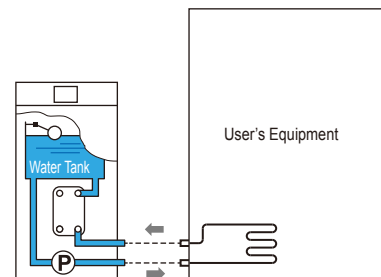

Energy-Saving, Precision Control, High-Spec

High

3-Series Lineup

Model		High-Spec Model Inverter control gives improved energy savings and high-precision temperature control.				
Series		RKE				
Air / Water Cooled		Air cooled			Water cooled	
Model *1		RKE 750A1-V-G2	RKE 1500B1-V-G2	RKE 2200B1-V-G2	RKE 1500B1-VW-G2	RKE 2200B1-VW-G2
Control Accuracy	°C	±0.1				
Power Source	V(Hz)	Three-phase 200 (50 / 60) 220 (60)				
Cooling Capacity*2	kW (50 / 60Hz)	2.9	5.8	9.5	6	10.4
Flow Rate	L/min (50 / 60Hz)	10 Head: 20 / 30 m	12 / 21 Head: 50 m	28 / 43 Head: 50 m	12 / 21 Head: 50 m	28 / 43 Head: 50 m

*1 G1 spec. also available without casters. *2 For operation on air-cooled machines when the chilled water temperature is 20 °C and the ambient temperature is 32 °C, or for water-cooled machines when the chilled water temperature is 20 °C and the cooling water temperature is 32 °C. Cooling capacity is at least 95% of listed figures.

Model		Mid-Spec Model RKE Economy Models Compact and Precision Temperature Control								Economy Model Compact and Economy		
Series		RKS-JM				RKS-JM		RKS-GM		RKS-J		
Air / Water Cooled		Air cooled						Water cooled			Air cooled	
Model *1		RKS 401J -MV	RKS 402J -MV	RKS 752J -MV	RKS 753J -MV	RKS 1502J -MV	RKS 1503J -MV	RKS402J-MVW	RKS 750G -MVW	RKS 1500G -MVW	RKS 753J -V	RKS 1503J -V
Control Accuracy	°C	±0.1								±2		
Power Source	V(Hz)	Single-phase 100 (50 / 60)	Single-phase 200 - 230 (50 / 60)		Three-phase 200 (50 / 60) 220 (60)	Single-phase 200 - 230 (50 / 60)	Three-phase 200 (50 / 60) 220 (60)	Single-phase 200 - 230 (50 / 60)	Three-phase 200 (50 / 60) 220 (60)		Three-phase 200 (50 / 60) 220 (60)	
Cooling Capacity*2	kW (50 / 60Hz)	1.3 / 1.5	1.3 / 1.5	2.2 / 2.5	2.2 / 2.5	4.9 / 5.3	4.9 / 5.3	1.3 / 1.5	2.2 / 2.5	4.9 / 5.3	2.2 / 2.5	4.9 / 5.3
Flow Rate	L/min (50 / 60Hz)	10 Head: 30 m	10 Head: 30 m	10 Head: 30 m	10 Head: 30 m	18 Head: 60 m	18 Head: 60 m	10 Head: 30 m	10 Head: 20 / 30 m	12 / 21 Head: 50 m	10 Head: 20 / 30 m	12 / 21 Head: 50 m

*2 For operation on air-cooled machines when the chilled water temperature is 20 °C and the ambient temperature is 32 °C, or for water-cooled machines when the chilled water temperature is 20 °C and the cooling water temperature is 32 °C. Cooling capacity is at least 95% of listed figures.

● Making the Right Model Choice

Sample cooler heat calculation and model selection methods are listed below. Please make a model choice that best suits your operating conditions and requirements.

Example 1 Find the cooling capacity required to deal with heat generated by a piece of equipment which is to be cooled by a chilled water flow ; the temperature difference between the cooling water going into and out of the equipment is known.

The equipment to be cooled is accepting a cooling water flow of 12 L/min, the water temperature going into the equipment is 17 °C, and the temperature of the water coming out is 20 °C . What is the amount of heat being generated by this equipment?

$$Q = \frac{(t_2 - t_1) \times X \times C \times \rho}{60} = \frac{(20 - 17) \times 12 \times 4.2 \times 1}{60} \approx 2.5 \text{ kJ/s} = 2.5 \text{ kW}$$

Note: When making a model selection, also consider heat from external sources that might raise the water temperature. In order to compensate for such external heat sources, it is recommended that an additional 20% in cooling capacity be added to the calculation. $Q = 2.5 \times 1.2 = 3.0 \text{ kW}$

Example 2 In case a certain temperature drop is required in a fixed amount of time.

For example, if 40 L of 20 °C water is in a separate tank, what is the heat dissipation required to lower the temperature of the water to 5 °C in one hour?

$$Q = \frac{W \times C \times (t_2 - t_1)}{H} = \frac{40 \times 4.2 \times (20 - 5)}{3600} = 0.7 \text{ kJ/s} = 0.7 \text{ kW}$$

Note: When making a model selection, also consider heat from external sources that might raise the water temperature. In order to compensate for such external heat sources, it is recommended that an additional 20% in cooling capacity be added to the calculation. $Q = 0.7 \times 1.2 = 0.84 \text{ kW}$

Q: Amount of heat in kW (kW = kcal/h)	t1: Lower temperature (°C)
W: Weight of cooling liquid (volume x specific gravity)	H: Required cooling time in hours
C: Relative heat in kcal/kg°C (in case of water: 1)	P: Power from an electric heater running 1 hour in kW
t2: Upper temperature (°C)	X: Water flow per minute: L/min

Application Examples by Series

High Energy Savings and Precision Control ($\pm 0.1^\circ\text{C}$)

RKE Series

Fiber Laser

Diode laser oscillator and optical systems cooling.



MRI

Helium compressor cooling and gradient coil cooling.



Photolithography Equipment

$\pm 0.1^\circ\text{C}$ cool water supply for exposure stage (cool plate).



High Frequency Induction Heating

Heating coil cooling and high frequency power supply cooling.



Plasma Welder

Cooling for power supply and welding torch.



ICP Analysis Equipment

Improved cooling efficiency for inspection solutions.



RKE Series Economy Models Offer Low Price in a Compact Design AND High Precision Temp. Control ($\pm 0.1^\circ\text{C}$)

RKS-JM Series

*If a water cooled model is needed, then please order from the RKS-GM Series.

Concentrating Equipment

Evaporator cooling.



Analysis Equipment

Analysis stage cooling.



X-Ray Inspection Equipment

X-Ray Tube Cooling.



UV Laser Engraving Machine

Laser Light-source Cooling.

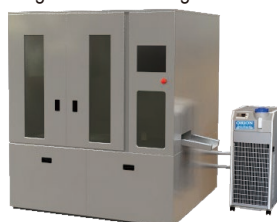

Molding Machines

Mold and hopper cooling.

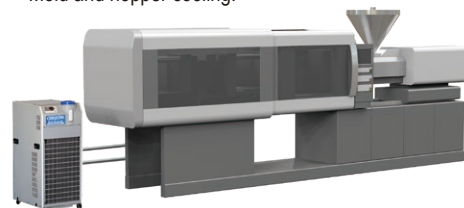

YAG Welding Machine

Laser Oscillator Cooling.



Printing Equipment

UV lamp cooling and ink drying cooling stage cooling as well as control over ink temperature.



Sheet Printing Machine

Individual roller cooling.

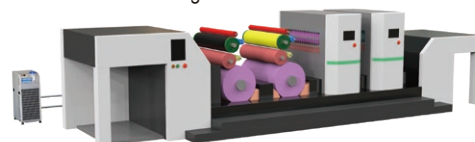

Compact and Economy

RKS-J Series

Milling Equipment

Jacket cooling.



Mixer

Jacket cooling.



Spot Welding Machine

Electrode and power supply cooling.



Arc Welding Machine

Power Supply and Torch Cooling.



Vacuum Vapor Deposition Equipment

Chamber cooling.



Packing Machinery

Cooling after heat sealing.



Laboratory Furnace/Kiln

Furnace/kiln cooling.



Dual Channel Chiller Lineup for Fiber Laser

Independent water circuits in a single chiller package provide different temp. settings for the oscillator and optical system. Please see the catalog for more detail.



10 Lineup: Dual Channel Chiller for Fiber Laser

Resonator Output	kW	1	2	3	4-6	7-8	10	1-2	3	4-6	7-8	10-12
Model		Air Cooled						Water Cooled				
		RKS 1500G MV-2CH	RKE 2200 B1-V-2CH	RKE 3750 B-V-2CH	RKE 5500 B-V-2CH	RKE 7500 B-V-2CH	RKE 11000 B-V-2CH	RKE 2200 B1-VW-2CH	RKE 3750 B-VW-2CH	RKE 5500 B-VW-2CH	RKE 7500 B-VW-2CH	RKE 11000 B-VW-2CH
Cooling Capacity	kW	3.9/ 4.3	7.7	11.2	19.3	24.0	36.2	9.4	13.1	22.4	26.3	42.0
Oscillator	Operable Liquid Temp.	5 - 35		3 - 35				5 - 35		3 - 35		
	Control Accuracy	± 0.1 (When load is stable.)										
	Flow Rate	L/min	12 / 21	28 / 43	15 - 50	60 - 95	60 - 170	100 - 230	28 / 43	15 - 50	60 - 95	100 - 230
Optical system	Operable Liquid Temp.	25 - 40 (Oscillator Water Temp. Setting +5 °C or higher)										
	Control Accuracy	± 1 (When load is stable.)										
	Flow Rate	L/min	24 / 52									
Power Source	V (Hz)	Three - phase 200 (50/60)										

RKE Series



Fully Loaded with Superior Functionality to Meet All the Requirements of Your Application and Working Environment.

High-Spec Model

RKE Series

Cooling Capacity _(50/60 Hz) :	2.7kW – 8.7 kW (Air Cooled)
	6.0kW – 10.4 kW (Water Cooled)
Ambient Temp. Range:	-5 – 43 $^{\circ}\text{C}$ (Air Cooled) 2 – 43 $^{\circ}\text{C}$ (Water Cooled)
Operable Temp. Range (Liquid temp.):	5 – 35 $^{\circ}\text{C}$
Temp. Control Precision:	$\pm 0.1\text{ }^{\circ}\text{C}$

Minimum 30 % Energy Savings* AND Precise Temperature Control of 0.1 $^{\circ}\text{C}$! * Compared with our earlier models.



RKE750A1-V-G2 RKE1500B1-V(W)-G2 RKE2200B1-V(W)-G2

* G1 spec. also available without casters.

Energy Saving

As much as 65% Energy Savings Possible

Even compared with power saving ON/OFF type chillers, our DC Inverter control models offer energy savings of 30 % at full load.

And when compared with temperature-stable hot gas bypass or PID proportional valve controlled chillers, a 65 % reduction in energy requirements is possible.

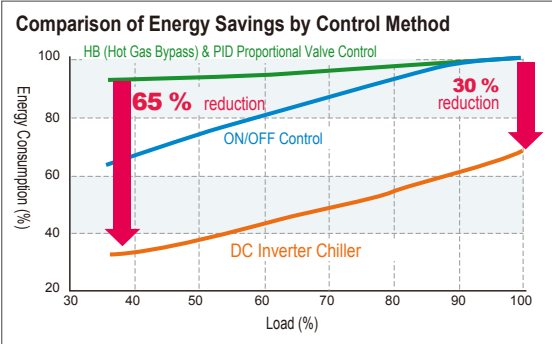

High Accuracy Temperature Control

Temperature Control Accuracy to $\pm 0.1\text{ }^{\circ}\text{C}$ *

Precise control even for applications that have severe temperature management requirements. Its extreme versatility makes it suitable for a wide range of applications, including precision-production-use lasers, analysis devices, semiconductor manufacturing, and many others.

* Under stable load and ambient temperature.



No Trade-Off between Low Energy and High Accuracy Control -- Now Orion Offers Both!

Our inverter controlled compressor responds to fluctuating workloads linearly, achieving highly accurate temperature control while using the least amount of energy.

Plus, thanks to Orion's distinctive capacity control system, accurate temperature control can still be maintained during normally difficult to control low load situations.

(User can choose between "High-accuracy" and "Energy saving" modes in response to low-load conditions.)

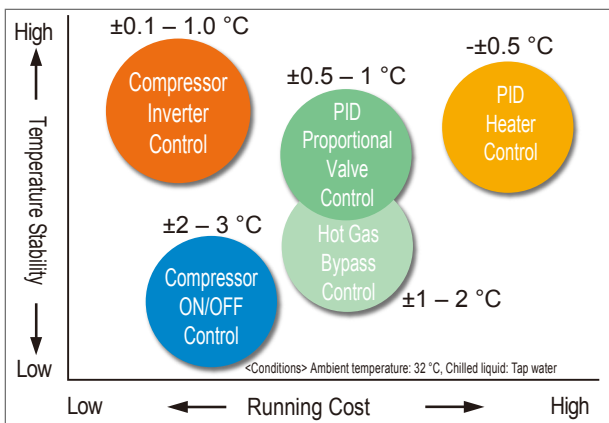

Wide Range of Operating Conditions

Liquid Temp. Control Range: 5 – 35 $^{\circ}\text{C}$ allows for wide-ranging applications. High temp. operation possible for piping condensation prevention, etc. Works in an increased range of ambient temperatures* from -5 to +43 $^{\circ}\text{C}$. (Water cooled types from +2 $^{\circ}\text{C}$.) This means our chiller can do its job under even harsher working conditions.

* For ambient temperatures below 5 $^{\circ}\text{C}$, measures must be taken to ensure that piping outside the chiller does not freeze.

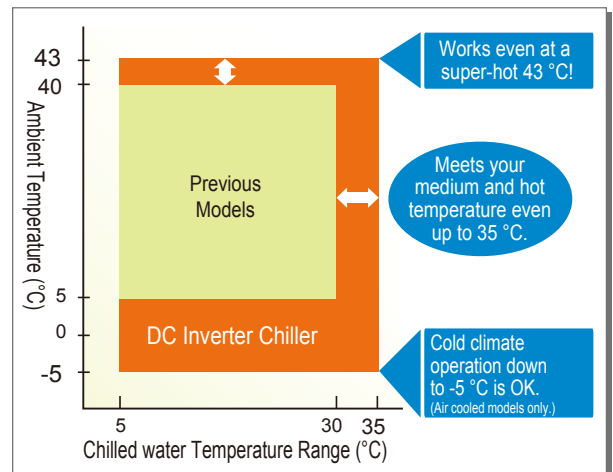

Built for Improved Ease of Use



Slanted front panel design is easy to see and easy to operate.



Tank access is at the top for easy access, easy water quality confirmation, easy cleaning!



Easy "One Touch" removable condenser dust filter. (Air cooled model only)

Wealth of Options and Multi-Function Parameters

Operation and control functions, as well as water temperature control conditions monitoring all from your PC via a single cable hookup.

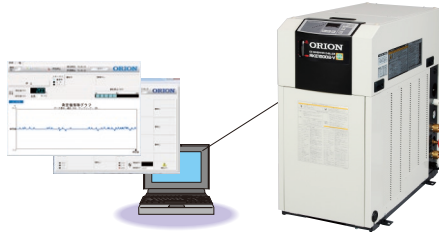

Equipped with a Wealth of Options.

Users have many options to choose from such as Remote control, Heaters, Communication software, and others to further suit their application requirements and operating environment. CE certification on built-to-order models is available.

Using the Multi-Function Parameters, users can tailor the chiller operation to best suit their many needs and operating conditions.

Function	Description
Power Outage Recovery Setting	"No recovery", "Auto recovery", "Remote switch priority", and "Either Local or Remote Switch On" options available.
Local or Remote Operation	Choose from: "Local Only", "Remote Only", "Both Local/Remote".
Alarm Signal Output	Can select signal contacts to be "Open" or "Closed" during an alarm condition.
Alarm State Operation Control	Options to "Continue" or "Halt" operation of still-working components under warning conditions.
Audible Alarm	Audible alarm "Enabled" or "Disabled" during alarm condition.
Audible Warning	Audible alarm "Enabled" or "Disabled" during warning condition.
Freeze Prevention Operation	To prevent freezing, auto pump operation "Enabled" and "Disabled" options available.
Warm-Up Mode	Option to keep pump running even when chiller is off, in order to maintain a (set) minimum liquid temperature.
Energy Saving Mode	Option to shut off compressor when cooling load falls below 40% for increased energy savings.
Low-Noise Mode	Option to reduce noise output by lowering the maximum fan speed to 40 Hz or lower. (Cooling power reduced about 20%)
500-Hour Filter Timer	Warning alarm to replace the filter after 500 hours can be enabled or disabled.
Liquid Temp High/Low Warning	5 patterns of water temperature limit settings are available.

Example of Energy Saving Configuration

RKS1500F-V → Changing to the **RKE1500B1-V**

Energy Saving → **44 %**

Reduced Output of CO₂ → **-1,013 kg CO₂/Year**

Effective Savings → **37,050 JPY/Year**

Energy Savings Points

**Got a Big Heat Load?
Change to an Inverter Chiller!**

● Comparison Conditions

Compared Models	RKS1500F-V (ON/OFF Control)
	RKE1500B1-V (DC Inverter Chiller)
Set Water Temp.	20 °C
Average Load	3.2 kW
Operating Time	10 Hours/Day (250 Days/Year)
Electricity Cost	15 JPY/kWh

● Power Consumption Rate Based On Chiller Load Factor

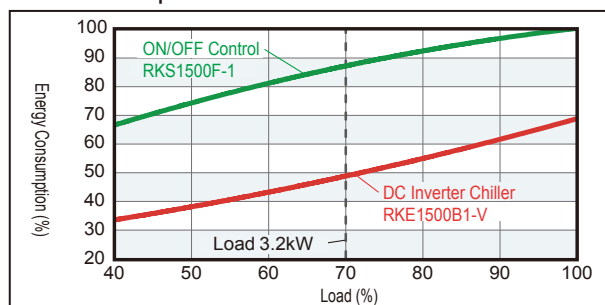

* The power consumption rate is a value achieved when the RKS1500F-V is operating under 60 Hz rated conditions at 100% (2.6 kW) power consumption.

● Amount of CO₂ Emission Reduction

* CO₂ emission coefficient used is 0.410, the average of 8 power companies.

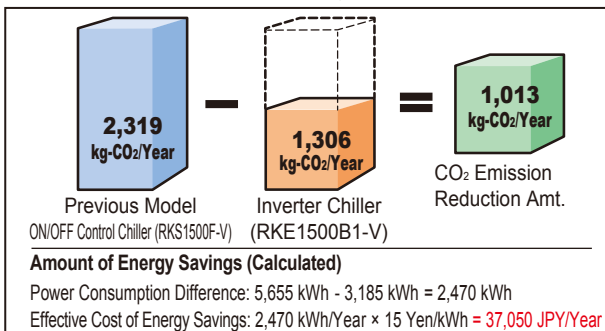

● Yearly Power Consumption Comparison

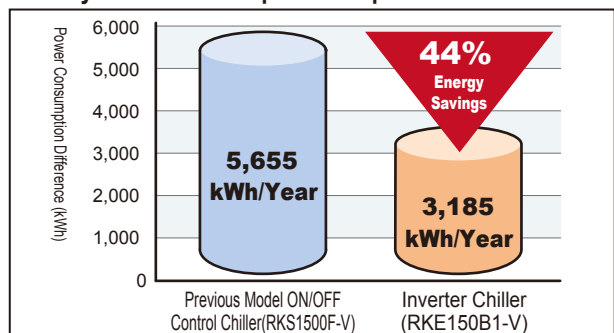

RKE Series

Specifications Chart

Model		Air Cooled				
		RKE750A1-V-G1 RKE750A1-V-G2 (w/ casters)	RKE1500B1-V-G1 RKE1500B1-V-G2 (w/ casters)	RKE2200B1-V-G1 RKE2200B1-V-G2 (w/ casters)		
Performance Specifications	Cooling Capacity	Room Temp. 32 °C, Set Temp. 20 °C ¹	kW	2.7	5.3	8.7
		Room Temp. 25 °C, Set Temp. 20 °C	kW	2.9	5.8	9.5
	Ambient Temp. Range	°C	-5 – 43			
	Operating Temp. Range (Liquid Temp.)	°C	5 – 35			
Control Precision ⁴	°C	±0.1 (Under stable load, ambient temperature and power source.)				
		±0.5 (When the current load is continuously within ±10%.)				
Min. Operating Circulation Rate (50/60 Hz)	L/min	10 (Head: 20 / 30 m)	12 / 21 (Head: 50 m)	28 / 43 (Head: 50 m)		
Power Source ²	V(Hz)	Three-phase 200±10 % (50 / 60), 220±10 % (60)				
Power Consumption ¹	kW	1.2 / 1.3, 1.3	2.3 / 2.4, 2.4	4.6 / 4.7, 4.7		
Electric Current ¹	A	4.5 / 5.3, 4.7	8.7 / 9.0, 9.0	16 / 17, 17		
Power Capacity ³	kVA	2.1	4.2	6.5		
Breaker Capacity	A	10 (With heater installed: 15) Current sensitivity: 30 mA, High-speed	15 (With heater installed: 20) Current sensitivity: 30 mA, High-speed	30 ⁵ Current sensitivity: 30 mA, High-speed		
Operation Control Method		Compressor Speed Control				
Compressor	Construction	Fully sealed rotary type (Inverter driven)				
	Output	kW	0.7	1.7		
Condenser	Fin and tube heat exchanger					
Heat exchanger	Construction	Plate type heat exchanger				
	Material	SUS316 (Brazing: Cu)				
Discharge Pump	Construction	Cascade type				
	Output	kW	0.25	0.40	0.75	
Water Tank Capacity	L	approx. 15		approx. 20		
Refrigerant	R-410A					
Charged Amount	kg	0.75	1.10	1.40		
CE Marking	Built To Order					
External Dimensions (H × D × W)	mm	G1: 840 × 688 × 400 G2: 927 × 688 × 400	G1: 879 × 850 × 400 G2: 966 × 850 × 400	G1: 993 × 970 × 530 G2: 1080 × 970 × 530		
Product Mass (Dry weight)	kg	G1: 68 G2: 73	G1: 96 G2: 100	G1: 135 G2: 140		
Operating Noise Level (50/60Hz) ⁵	dB	55 / 57	56 / 60	62 / 64		

Model		Water Cooled			
		RKE1500B1-VW-G1 RKE1500B1-VW-G2 (w/ casters)	RKE1500B1-VW-G1 RKE1500B1-VW-G2 (w/ casters)	RKE2200B1-VW-G1 RKE2200B1-VW-G2 (w/ casters)	
Performance Specifications	Cooling Capacity	Room Temp. 32 °C, Set Temp. 20 °C ¹	kW	6.0 (Chilled water temp.: 20 °C)	10.4 (Chilled water temp.: 20 °C)
		Room Temp. 25 °C, Set Temp. 20 °C	kW		
	Ambient Temp. Range	°C	2 – 43		
	Operating Temp. Range (Liquid Temp.)	°C	5 – 35		
Control Precision ⁴	°C	±0.1 (Under stable load, ambient temperature and power source.)			
		±0.5 (When the current load is continuously within ±10 %.)			
Min. Operating Circulation Rate (50/60 Hz)	L/min	12 / 21 (Head: 50 m)		28 / 43 (Head: 50 m)	
Power Source ²	V(Hz)	Three-phase 200±10 % (50 / 60), 220±10 % (60)			
Power Consumption ¹	kW	1.7 / 1.8, 1.8		3.5 / 3.7, 3.7	
Electric Current ¹	A	6.5 / 7.1, 6.6		14 / 14, 14	
Power Capacity ³	kVA	3.0		5.5	
Breaker Capacity	A	15 (With heater installed: 20) Current sensitivity: 30 mA, High-speed		30 ⁵ Current sensitivity: 30 mA, High-speed	
Operation Control Method		Compressor Speed Control			
Compressor	Construction	Fully sealed rotary type (Inverter driven)			
	Output	kW	0.7	1.7	
Condenser	Double pipe water cooling				
Heat exchanger	Construction	Plate type heat exchanger			
	Material	SUS316 (Brazing: Cu)			
Discharge Pump	Construction	Cascade type			
	Output	kW	0.4	0.75	
Water Tank Capacity	L	approx. 15		approx. 20	
Refrigerant	R-410A				
Charged Amount	kg	0.80		1.10	
CE Marking	Built To Order				
External Dimensions (H × D × W)	mm	G1: 879 × 850 × 400 G2: 966 × 850 × 400		G1: 993 × 970 × 530 G2: 1080 × 970 × 530	
Product Mass (Dry weight)	kg	G1: 95 G2: 98		G1: 135 G2: 140	
Operating Noise Level (50/60Hz) ⁵	dB	55		59 / 60	

¹ For operation on air-cooled machines when the chilled water temperature is 20 °C and the ambient temperature is 32 °C, or for water-cooled machines when the chilled water temperature is 20 °C and the cooling water temperature is 32 °C. Cooling capacity is at least 95% of listed figures. ² Source voltage phase unbalance should be less than ±3%. ³ The figure noted is when operating at the highest capacity in the normal operating range. ⁴ Does not include starting times or when the cooling load is too small, in which case the compressor may cycle on and off. ⁵ Operating noise levels are from a position of 1 m in front of the product and at a height of 1 m. ⁶ Unit comes with a built-in overload protection breaker.

Note 1: Liquid (chilled water) that can be used are either clean water and a 30 to 40% ethylene glycol solution. Note that there will be a drop in cooling capacity of 10% if using a 30 to 40% ethylene glycol solution. Alternatively, if deionized water is to be used, it should have an electrical conductivity of at least 1 µS/cm.

Note 2: Do not use aluminum parts for parts that will be wetted with the chilled water. Electrolytic corrosion of aluminum can cause clogging in the heat exchanger.

Note 3: Heat output from the unit (in kW) is approx. 1.3 times that of the cooling capacity.

Cooling Capacity

RKE750A1-V

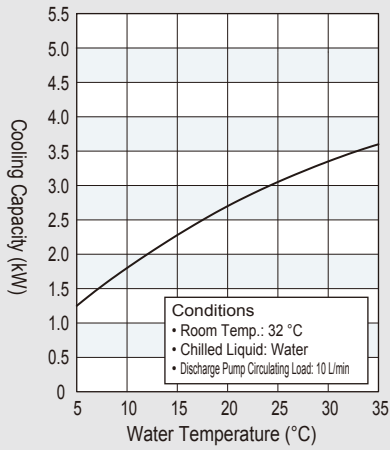

RKE1500B1-V
RKE1500B1-VW

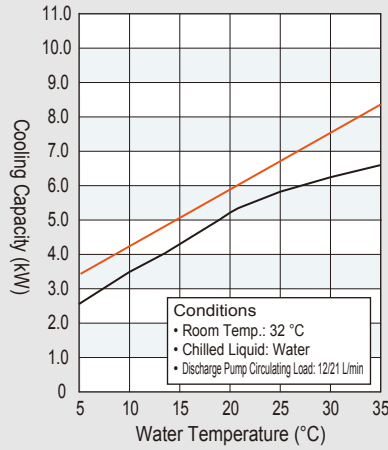

RKE2200B1-V
RKE2200B1-VW

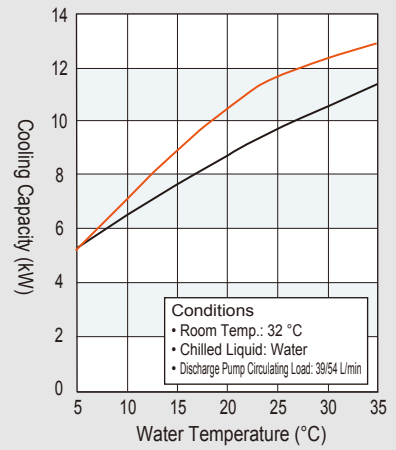

Minimum Heat Requirement for Inverter Control <Conditions> Chilled Liquid: Water

* Even in the high accuracy mode, if the amount of heat to process is below the minimum level, the compressor will cycle ON and OFF, and may affect the control accuracy.
* If the minimum heat requirement for inverter control is not met and high accuracy temperature control is necessary, please install the optional heater assembly unit, or ask for a special model equipped with a capacity control valve.

RKE750A1-V

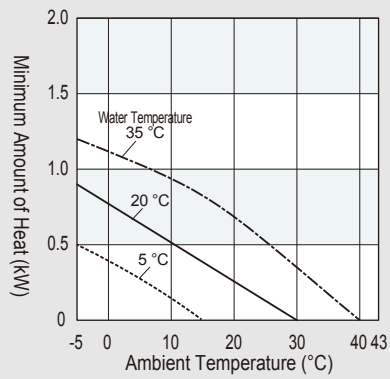

RKE1500B1-V
RKE1500B1-VW

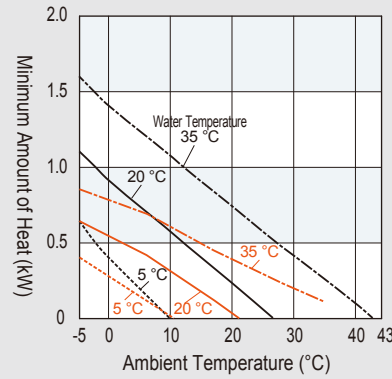

RKE2200B1-V
RKE2200B1-VW

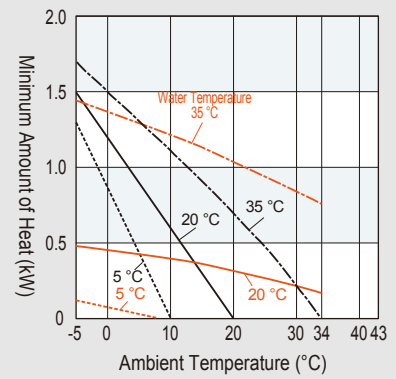

Discharge Pump Characteristic Curves Pump-only operation rating.

RKE750A1-V

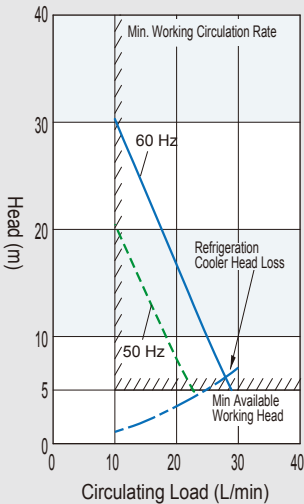

RKE1500B1-V/VW

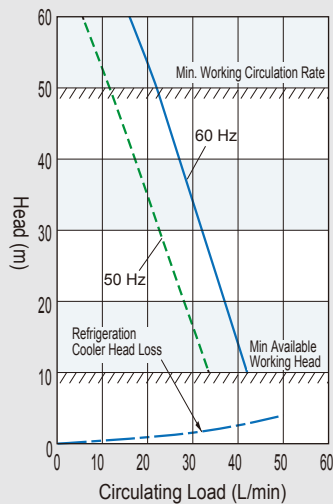

RKE2200B1-V/VW

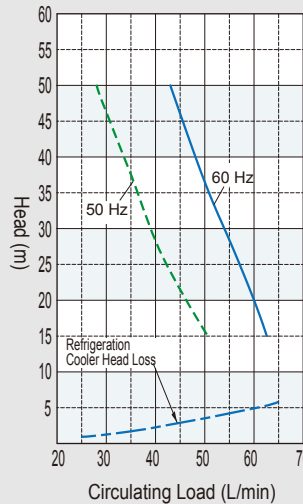

Cooling Water Flow Rate (For condenser)

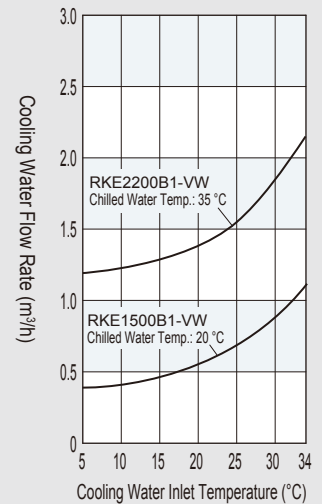

RKE Series

External Dimensions (Units: mm)

RKE750A1-V-G1 • G2 (Incl. casters)

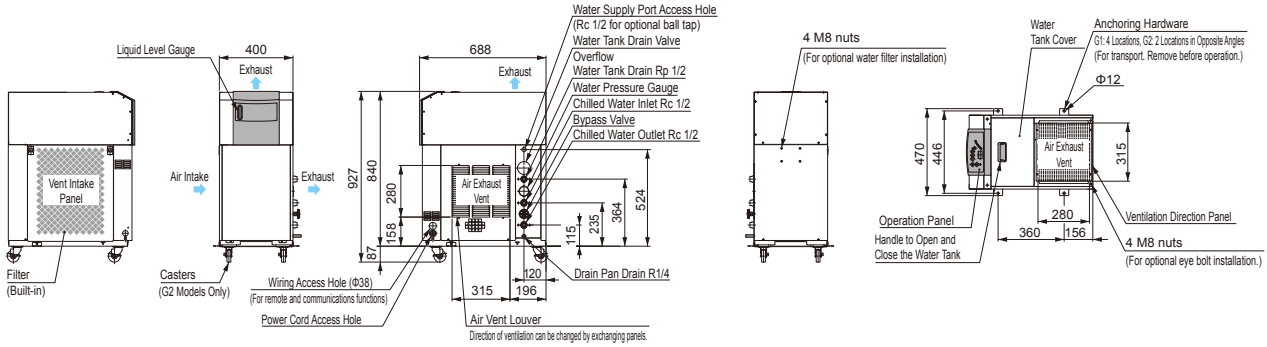

Includes Power Cord (Length outside the product: 3 m) 2 mm² x 4-conductors

RKE1500B1-V-G1 • G2 (Incl. casters)

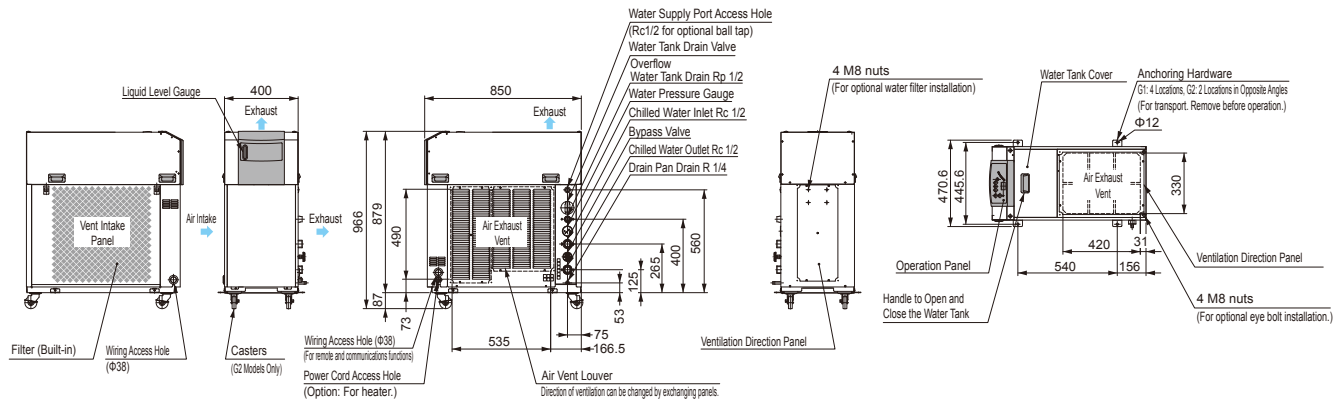

Includes Power Cord (Length outside the product: 3 m) 3.5 mm² x 4-conductors

RKE2200B1-V-G1 • G2 (Incl. casters)

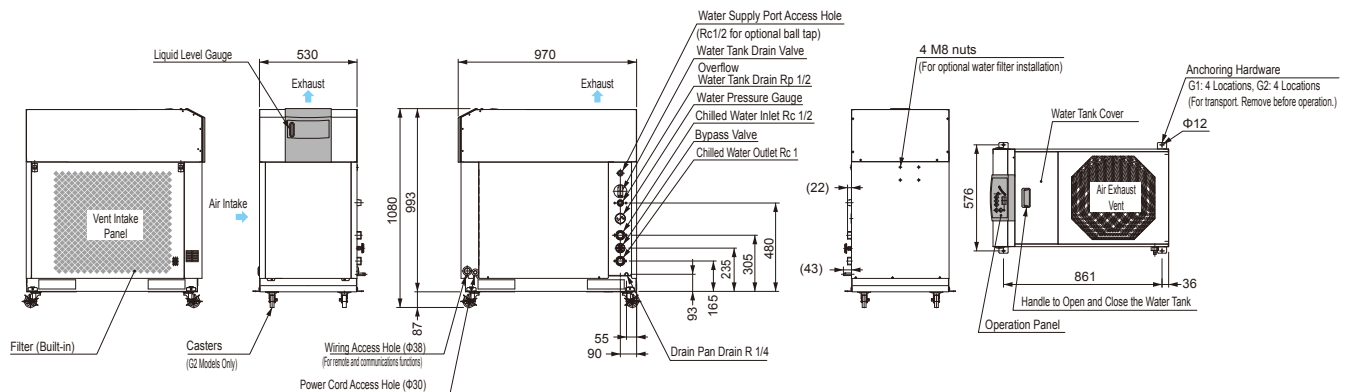

RKE1500B1-VW-G1• G2 (Incl. casters)

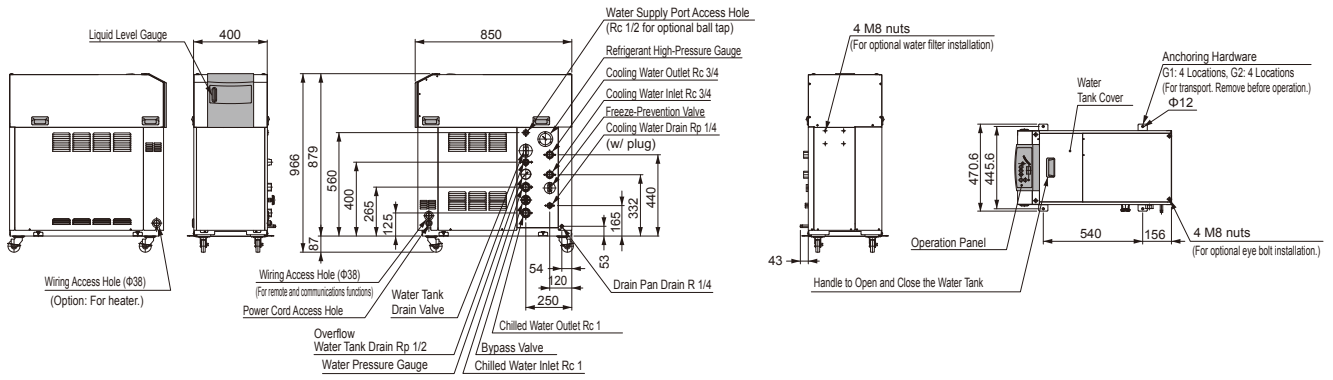

Includes Power Cord (Length outside the product: 3 m) 2 mm² x 4-conductors

RKE2200B1-VW-G1• G2 (Incl. casters)

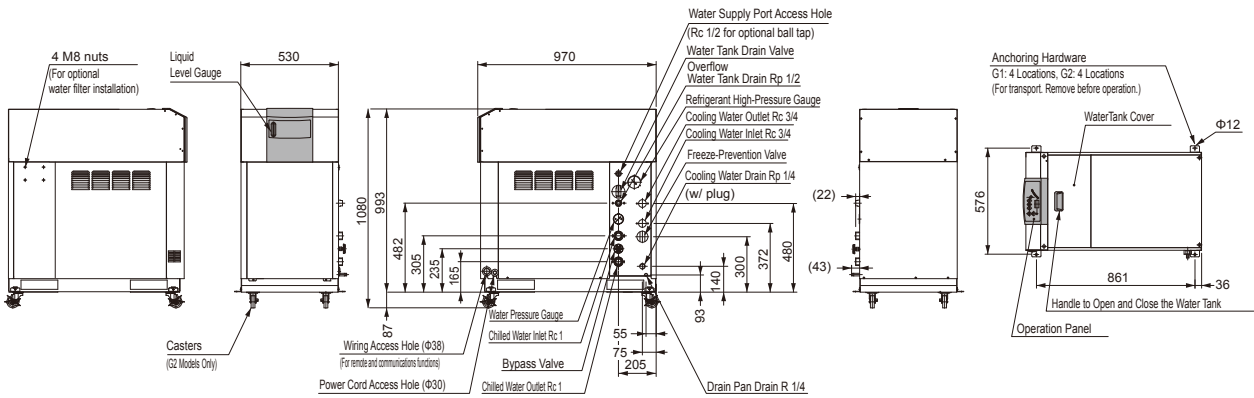

- *1: Signal lines and power cords should be routed through different access holes.
- *2: Casters are only included with the G2 models.
- *3: When using the water supply port, the optional ball tap assembly should be installed.
- *4: Either prepare a container to collect the water from the drain pan drain or lead the drain water away to a drainage collection site using a hose or other means.
- *5: Piping connection dimensions in the illustration have a maximum tolerance of ±2 mm.

RKE Series

Equipment List

	Item Detail	Function	Comments	Model (RKE Series)					
				750A1-V	1500B1-V	2200B1-V	1500B1-VW	2200B1-VW	
Operating Environment	30 to 40% solution of industrial-use ethylene glycol. *3			Standard Equipment					
	Deionized water Electrical Conductivity: 1 $\mu\text{S/cm}$ or Higher		Wetted parts are copper-free. *4	★					
	Working Liquid (Chilled water) Temp.		5 - 35 $^{\circ}\text{C}$ 0 - 35 $^{\circ}\text{C}$		Standard Equipment				
	Freeze-Prevention Mode		This function operates the discharge pump in order to prevent water temperature drops and freezing during winter months when unit operations is stopped. When enabled, the discharge pump will operate when the water temperature falls to 3 $^{\circ}\text{C}$ or below.	Control panel can be enabled or disabled. *Cannot be used at the same time as the warming up mode.	Standard Equipment				
	Warm Up Mode		This function will automatically operate the discharge pump at times when the product is otherwise not operating when the ambient temperature is low, for example during winter months, in order to prevent the water temperature from dropping too much and in order to help maintain the set water temperature. When the mode is enabled, the water temperature can be set between 10 $^{\circ}\text{C}$ and 35 $^{\circ}\text{C}$.	Control panel can be enabled or disabled. *Cannot be used at the same time as the freeze-prevention mode.	Standard Equipment				
	Low Noise Mode		This function will limit the upper speed of the fan and the fan ventilation noise level will be decreased.	Can be enabled or disabled via the control panel.	Standard Equipment				
	Leakage Alarm Spec.		In addition to the standard specification, leak-detect spec. models include leak-detection functionality (leakage sensor and leakage detection unit) built in. Pressure resistant piping, insulated refrigeration, piping, insulated water piping standard. (For models specified with leak detection specifications.)		★				
	Water Leakage Detection		In addition to the standard specification, leak-detect spec. models include leak-detection functionality (leakage sensor and leakage detection unit) built in.		★				
	Vibration Reducing Base	Reduces transmission of vibration from the chiller.		0A003698000	0A002692000	0A003448000	0A002692000	0A003448000	
Chilled Water Circuit	Discharge Pump Specs. *1		High-head pump Please consult us on each occasion.	★					
	Relief Valve (Pressure valve)		Can provide equipment-side pressure protection.	Pressure valve: Set to 0.3 - 0.5 MPa. (If a pressure greater than 0.5 MPa is desired, please consult your dealer regarding pressure-resistance of the product and the installed pump. Our dealers are glad to assist you at any time.)	★				
	Water Tank Water-Level Alarm (Lower limit alarm)		Used to avoid water shortages due to evaporation.		Standard Equipment				
	Automatic Water Supply		A ball tap is provided in the water tank in order to maintain a uniform water level. Shipped with ball tap pre-installed.	The special ball tap is installed on-site. *2	03101256010	03101256010	03103698010	03101256010	03103698010
	Chilled Water Inlet/Outlet Open/Close		Gate valves are added to the chilled water inlet and outlet ports.	Gate Valve: Same port diameter as the product inlet and outlet ports. (Material: Choose between SUS or brass.)	Brass				
					04106229010	04106229030			
			SUS						
			Solenoid valve are added to the chilled water inlet and outlet ports.	Solenoid Valve: Same port diameter as the product inlet and outlet ports (Material: brass).	★				
			Compression fittings are added to the chilled water inlet and outlet ports.	Hose Coupling: Port diameter matched to the product inlet and outlet ports.	04106230010	04106230020			
	Chilled Water Circuit Water Filter		Water Filter A Assembly	Choose the filtration level. (5 μm)	03108547010				
			Water Filter A Assembly	Choose the filtration level. (10 μm)	03108547020				
			Water Filter A Assembly	Choose the filtration level. (20 μm)	03108547030				
			Water Filter A Assembly	Choose the filtration level. (50 μm)	03108547040				
			Water Filter A Assembly	Choose the filtration level. (100 μm)	04100489010				
	Deionized Water Equipment for Chilled Water Circulation Circuit		Deionizer "F" Assembly	Water sample quality of 10 $\mu\text{S/cm}$ or lower.	04101157010	—	04101157010	—	—
Deionizer "H" Assembly			—						
Deionizer "G" Assembly			—		04103028010	—	04103028010		
Deionized Water Equipment for Chilled Water Circulation Circuit		Deionizer assembly for supply water		04100522010					
Cooling Water (Condenser circuit) Inlet/Outlet Open/Close *Model names ending with "W" are targeted for water cooled chillers.		Gate valves are added to the cooling water inlet and outlet ports.	Gate Valve: Same port diameter as the product inlet and outlet ports. (Material: Choose between SUS or brass.)	—					
		Cooling water inlet and outlet ports have solenoid valves added.	Solenoid Valve: Same port diameter as the product inlet and outlet ports (Material: brass).	—					
		Compression fittings are added to the cooling water inlet and outlet ports.	Compression Fitting: Port diameter matched to the product inlet and outlet ports.	—					
Bypass Circuit		The bypass circuit is operated by manually opening and closing the cooling water circuit valves.	RKE models have the bypass circuit built-in. The circuit is external on RKS models.	Standard Equipment (Built-in)					
Primary Power Supply Voltage		Three-phase 200 V (50/60 Hz), Three-phase 220 V (60 Hz)		Standard Equipment					
		Three-phase 230 V (50 Hz), 380 V • 400 V • 415 V • 440 V • 480 V (50/60 Hz)	The autotransformer is installed externally.	★					
Overload Safety Devices		Built-in overload safety device.	RKE2200 models come standard with an earth leakage breaker (current sensitivity: 30 mA) and RKS series models come standard with a no-fuse breaker. *RKE750/1500 models and RKS models have a leakage breaker available as a manufacturer option.	★	Standard Equipment	★	Standard Equipment		
Power Outage Recovery Operation Settings		Selects recovery pattern after power outage. (Manual recovery • Automatic recovery • Remote operation priority)	Action to be taken after recovery can be enabled or disabled via the control panel.	Standard Equipment					
Operation Action Settings		Can choose between "Local" and "Remote" operation.	Can be set from the control panel.	Standard Equipment					
Alarm Signal Output Options		Can choose the contact state of the remote alarm signal output. (Relay contacts either OPEN or CLOSED during an alarm condition.)	Can be set from the control panel.	Standard Equipment					
Audible Alarm Enable/Disable		The audible alarm/warning can be enabled or disabled.	The audible alarm can be enabled or disabled via the control panel.	Standard Equipment					
Liquid (Chilled Water) Temp. Upper/Lower Limit Warning Option		The method of abnormal liquid (chilled water) temperature detection can be selected. Can enable or disable the alarm and standby sequence for relative value and absolute value alarms. *Regarding the standby sequence, the alarm will be output after startup until the liquid temperature has initially reached a normal value and then later goes outside the normal range.	Can be set from the control panel.	Standard Equipment					

Function		Model (RKE Series)						
		750A1-V	1500B1-V	2200B1-V	1500B1-VW	2200B1-VW		
Power Supply and Control Specs.	Liquid (Chilled Water) Temp. Upper/Lower Limit Warning / Absolute Value Upper Limit	The warning will occur if the water temperature goes above the set temperature (2 - 40 °C) regardless of the actual set water temperature. Will be active when the "Liquid (Chilled Water) Temperature Upper/Lower Limit Warning" Absolute Value has been selected.	Water temperature setting can be set from the control panel.					
	Liquid (Chilled Water) Temp. Upper/Lower Limit Warning / Absolute Value Lower Limit	The warning will occur if the water temperature goes below this set temperature regardless of the actual set water temperature.	Water temperature setting can be set from the control panel.					
	Remote Control	By connecting a remote control to the product, the product can be run and other operations can be conducted (limited control) from a control panel in a location away from the product. Operating parameters can also be displayed.	Remote Control Set C	04100949010				
			Max. wiring length: 20 m	04100541010				
			Max. wiring length: 50 m	04100541020				
			Max. wiring length: 100 m	04100541030				
	Communications Functions	Communications Interface and Software	Available for free download at the website.					
	Communications Device Address	Enables communications functions and selects the address number of the unit when multiple units are connected together.	Standard Equipment					
	Settings Lock	Changes to the water temperature setting and other parameter settings can be locked out.	Can enable or disable setting changes from the control panel.					
	Temperature Warning Signal Output Option	Determines the open/closed state of contacts when a temperature warning signal is present.	The type of relay output (ON/OFF) when an alarm condition occurs can be selected from the control panel.					
	External Signal Operation	Operation Signal Terminal Block	No-voltage contacts	Standard Equipment				
			Voltage output (200 V output)	★				
		Alarm Signal Terminal Block	No-voltage contacts	Standard Equipment				
			Voltage output (200 V output)	★				
		Remote Operation (No-voltage contacts)	Max. wiring length: 20 m	Standard Equipment				
Max. wiring length: 100 m			★					
Remote Operation (24 Vdc Output)	Max. wiring length: 20 m (Circuit board takes 24 Vdc input power.)	★						
	Max. wiring length: 100 m (Circuit board inputs are activated via a 24 Vdc input actuated relay on the circuit board.)	★						
Remote Operation (200 Vac Output)	Max. wiring length: 20 - 100 m (Circuit board inputs are activated via a 200 Vac input actuated relay on the circuit board.)	★						
Other	CE Marking	CE Compliant Model	★					
	Casters	With lock	2 locking freewheeling casters and 2 non-locking freewheeling casters.	★				
			2 free-wheeling casters, 2 fixed casters	★				
			4 free-wheeling casters	Standard Equipment(G2)				
	External Surface Coating Thickness	Powder Coating: 30 μm	Standard Equipment					
		Salt Corrosion Prevention Spec. (Powder coating of at least 45 μm.)	Use external screws are made of stainless steel. Condenser and refrigerant piping coated with a corrosion resistant coating.					
	Color Designation *Specify the color designation as a JPMA No. or Munsell No (including a color sample).	Melamine resin coating of at least 15 μm.	★					
		For other paint / coatings:	★					
	Packaging for Export	Basic plywood packaging	Please consult your dealer for details regarding JIS standard packaging.					
	Water Temperature Control Accuracy	±0.1 °C	Standard Equipment					
Heating Functionality	Used to raise the temperature during product startup. (Built in 200 Vac electric heater.) *ON/OFF control to the set Liquid temperature minus 2 °C ± 0.5 °C.	Heating output: Selectable among 2 kW, 3 kW, 4 kW, 5 kW, or 5 kW × 2.						
Low-Load Response	When high-precision control is required at loads below the minimum required amount.	Optional Heater Control *5	03101359010 (1.5 kW)	03104635010 (1.8 kW)	03101359010 (1.5 kW)	03104635010 (1.8 kW)		
		CCV Circuit Added	★	★	—	★	—	
Test Results Chart	Japanese	★						
	English	★						
Test Results Chart	Japanese	★						
	English	★						
Initial Inspection		★						

- * 1: Cooling capacity will be reduced by an amount just equal to the amount of pump heat dissipation.
- * 2: Cannot be connected directly to city tap water. Supply water using a back-flow device for the water supply tank or cistern, etc.
- * 3: Max. decrease in cooling capacity is 10 %.
- * 4: Copper alloy is used for wetted parts on standard units.
- * 5: We can also provide an optional heater that will operate when starting operation.

<Please Note>
Specifications for optional factory equipment may change without notice. Thank you for your understanding.

Mid-Grade Model

RKS-JM Series

New Model Compact Chiller No. 1 Performer in a Compact Body

Loaded with Application Functionality that Conforms

Mid-Grade Model

JM Series



High Precision Temperature Control + Inverter Driven High Pressure Pump + High Ambient Temp Compatibility

Cooling Capacity (50/60 Hz):	1.3/1.5 kW _(RKS401/402J-MV)
	2.2/2.5 kW _(RKS752/753J-MV)
	4.9/5.3 kW _(RKS1502/1503J-MV)
Operable Ambient Temperature:	5 – 45 °C
Working Liquid Temperature:	5 – 40 °C
Temperature Control Accuracy:	±0.1 °C

The electronic expansion valve control achieves ±0.1 °C high precision temperature control that translates to increased equipment production accuracy and quality.

Our standard built-in high-pressure pump is inverter driven, thus achieving the same performance specifications even in regions that have different power frequencies.

Wide Operable Ambient Temperature Range of 5 – 45 °C. Working Liquid Temperature Range of 5 – 40 °C Supports Many Working Environments.

CE and UL Targeted 3-Model Lineup

Three Single-Phase 200 to 230 V Power Models: RKS402J-MV, RKS752J-MV, and RKS1502J-MV.

The 4 models ending in -00000, -01000, -10000, and -11000 are CE and UL standards compliant. Models with other model numbers are available as with CE compliance via special order. See page 21 for model descriptions.



RKS401/402J-MV

RKS752/753J-MV

RKS1502/1503J-MV

Uses Chilled Water, Suitable for a Wide Variety of Applications

Perfect for environments where heat is the enemy!

Heat Removal and Water Temperature Control for Semiconductor Research and Manufacturing Equipment, Rechargeable Cell Research and Manufacturing Equipment, Precision Measurement Equipment and Precision Processing Machines, Analysis Equipment, Medical Equipment, etc.



*Chilled water is not CE or UL certified.



RKS402J-MVW

Condensed
Functionality! Even
Easier to Use!

ms to Your Operating Environment!

Comes Standard with High Pressure Pump (Same capacity for 50/60 Hz regions)

The high pressure pump that comes standard with RKS-JM Series models is an inverter driven pump that maintains its compact size while ensuring a 10 L/min flow rate at a water pressure of 0.3 MPa. The same flow capacity is achieved even in regions with different power frequencies, so operation stability can be assured even if moved to different factory facilities.



Made Even Easier to Use! Simple and Reassuring Design

Common on All RKS J(M) Series Models

Simple and Reliably Designed Controller + Substantial Functionality

Easy operation with just the flick of a switch! Alarm details via error code display for quick recovery.

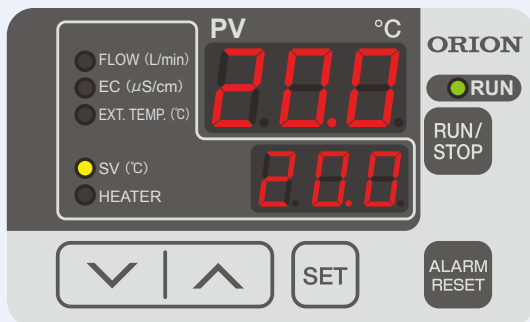

Output Signals

- Operation Signal
- Alarm Signal
- Remote Signal

Operation Signal

- Freeze-Prevention Mode
- Warm Up Mode
- Discharge Pump-Only-Operation
- Automatic Recovery After Power Outage, etc.

Large Capacity Tank with Wide Water Supply Port



Φ100 mm large water supply port for easy cleaning! The high capacity tank means less frequent water shortage warnings, less frequent water supplying, and less change in water temperature due to changing loads. A built-in blue LED lit water indicator for easy confirmation of water level!



Wide mouth water supply port for easy tank cleaning.



Easy to check LED lit water level gauge.

Easy Filter Cleaning

Comes standard with a filter to help prevent clogging! Easy tool-less removable filter design. Filter can be directly cleaned for easy removal of dirt and reduced manpower, adding to chiller operating stability.



RKS-JM Series

Specifications Chart: Standard Models

Model		RKS-JM Series							
		401J-MV	402J-MV	752J-MV	753J-MV	1502J-MV	1503J-MV	402J-MVW	
Performance Specifications	Cooling Capacity (50/60 Hz)	1.3 / 1.5		2.2 / 2.5		4.9 / 5.3		1.3 / 1.5	
	Heating Capacity (50/60 Hz)	0.53 / 0.53		0.6 / 0.6		1.1 / 1.1		0.38 / 0.42	
	Ambient Temp. Range	5 – 45							
	Operating Temp. Range (Liquid Temp.)	5 – 40							
	Operating Water Pressure	0.05 – 0.3			0.1 – 0.6		0.05 – 0.3		
Control Precision	±0.1								
Min. Operating Circulation Rate (50/60 Hz)	10 (Head: 30 m)								
Power Specifications	Power Source	Single-phase 100 ±10% (50/60)	Single-phase 200 – 230 ±10% (50/60)		Three-phase 200 (50/60) • 220 (60) ±10%		Single-phase 200 – 230(50/60) -5%, +10%	Three-phase 200 (50/60) • 220 (60) ±10%	Single-phase 200 – 230(50/60) ±10%
	Power Consumption (50/60 Hz)	0.8 / 0.7	0.9 / 1.0	1.1 / 1.2	0.9 / 1.0, 1.0	2.0 / 2.5	1.8 / 2.2, 2.2	0.6 / 0.6	
	Electric Current (50/60 Hz)	7.9 / 7.3	3.8 / 4.7	5.2 / 5.4	3.6 / 3.4, 3.4	9.5 / 11.3	6.6 / 8.2, 8.2	3.2 / 3.0	
	Power Capacity	1.2	1.5	2.0	2.0	4.2	4.2	1.3	
	Breaker Capacity	15	10	15	10	30	15	10	
Operation Control Method		Electronic expansion valve capacity control							
Equipment Details	Compressor	Hermetically sealed rotary type							
	Condenser	Corrugated fin and tube parallel flow type							
	Evaporator	Plate type heat exchanger							
		SUS316 (Brazing: Cu)							
	Discharge Pump	Cascade type							
	Water Tank Capacity	0.25 (Inverter driven)			0.4 (Inverter driven)		0.25 (Inverter driven)		
	Refrigerant	R-410A							
Charged Amount	0.36		0.37		0.65	0.59	0.45		
External Dimensions (H × D × W)	615 × 500 × 375								
Product Mass (Dry weight)	42		45	46	72	68	44		
Export Standard CE and UL (60 Hz only)	—								
Operating Noise Level	59 / 62	59 / 60	61 / 62	62 / 63	64 / 65	65 / 66	54 / 55		

*1 Under the following conditions: Chilled water temp.: 20 °C, Ambient temp.: 25 °C, Max. discharge pump circulating load. Cooling capacity is at least 95 % of listed figures. Heating capacity will change according to operating conditions.
 *2 Source voltage phase unbalance should be less than ±3 %. *3 The figure noted is when the equipment is operating at the highest capacity of its normal operating range. *4 When the current load is continuously within ±10 %, and the ambient temperature is stable. However does not include starting times or when the heat-load exceeds the chiller capacity.
 *5 Comes standard with a built-in overload protection circuit breaker (NFB). *6 Operating noise levels are from a position of 1 m in front of the product and at a height of 1 m.
 Note 1: Liquid (chilled water) that can be used are either clean water and a 30 to 40% ethylene glycol solution. Note that there will be a drop in cooling capacity of 10% if using a 30 to 40% ethylene glycol solution. Alternatively, if deionized water is to be used, it should have an electrical conductivity of at least 1 µS/cm.
 Note 2: Do not use aluminum parts for parts that will be wetted with the chilled water. Electrolytic corrosion of aluminum can cause clogging in the heat exchanger.
 Note 3: Heat output from the unit (in kW) is approx. 1.3 times that of the cooling capacity.
 Note 4: Depending on the operating environment, condensation may form on piping inside the product, and temporary leakage of water from the pump mechanical seals may also occur, therefore a drain pan should be installed if required.

Cooling Capacity

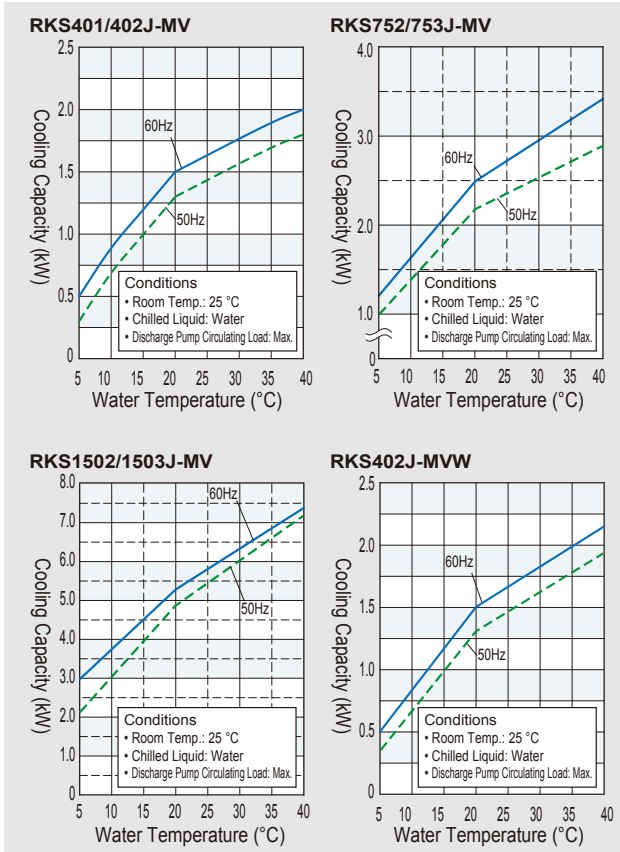

Discharge Pump Characteristic Curves

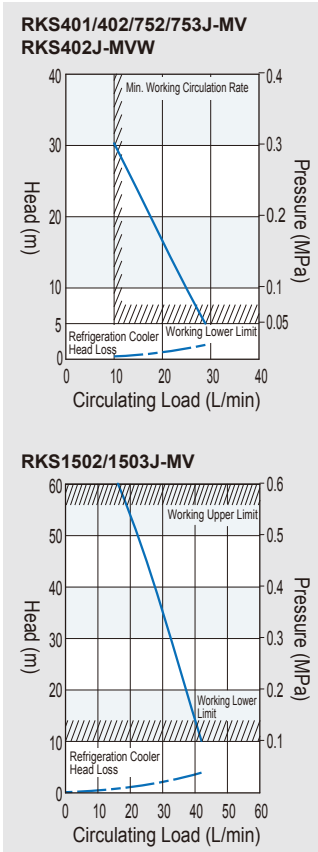

Operating Temp. Range

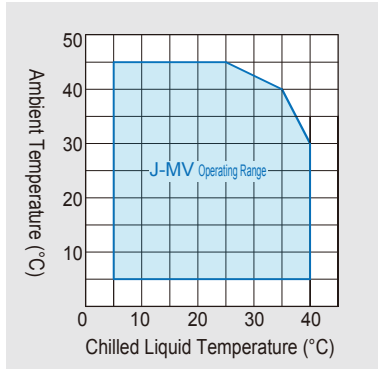

Cooling Water Flow Rate (for condenser)

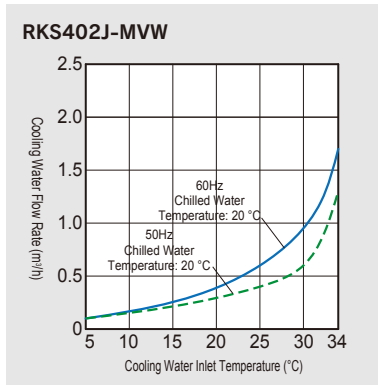

Discharge Pump Characteristic Curves (For factory options)

**High Head / High Flow-Rate Pump
For RKS402/75□J-MV**

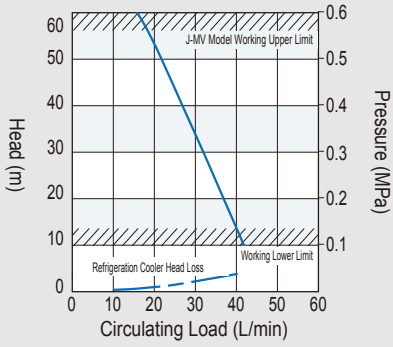

**Pump w/Copper-Less Spec. Wetted Parts
For RKS40□/75□J-MV**

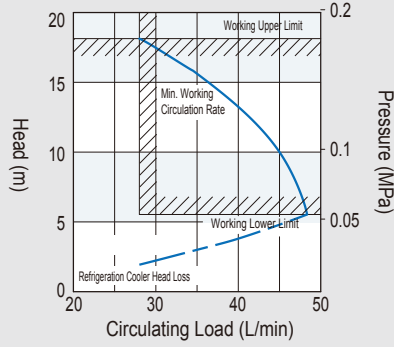

**Pump w/Copper-Less Spec. Wetted Parts
For RKS150□J-MV**

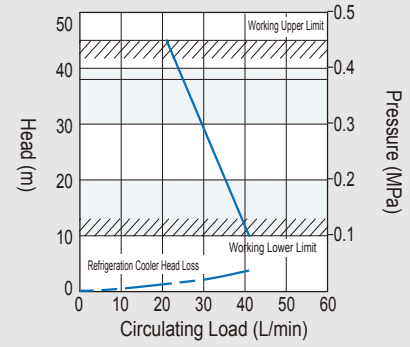

External Dimensions (Units: mm)

**RKS401J-MV
RKS402J-MV
RKS752J-MV
RKS753J-MV**

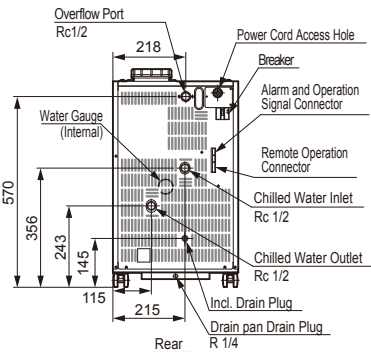
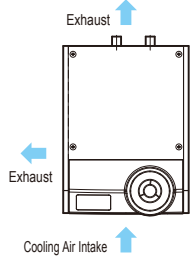

**RKS1502J-MV
RKS1503J-MV**

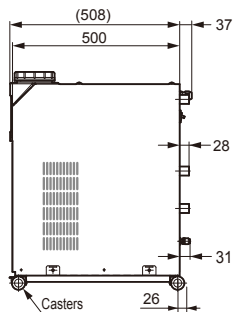
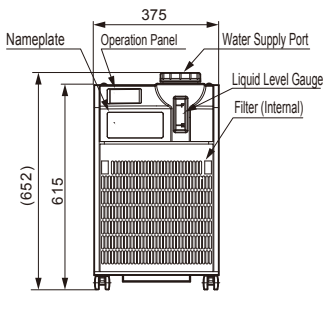
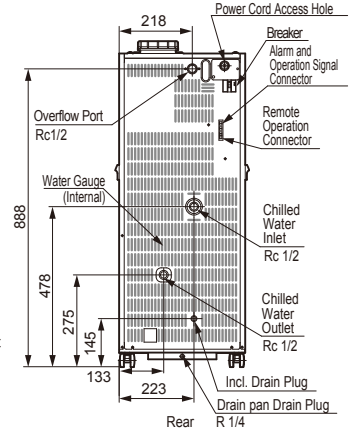
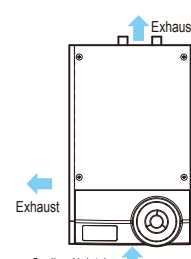

RKS402J-MVW

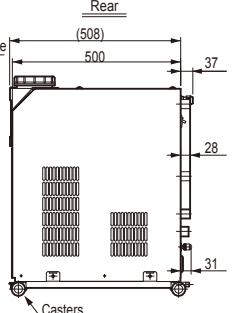
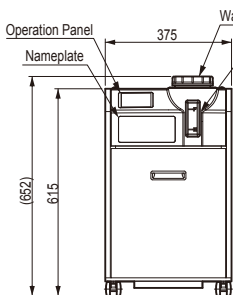
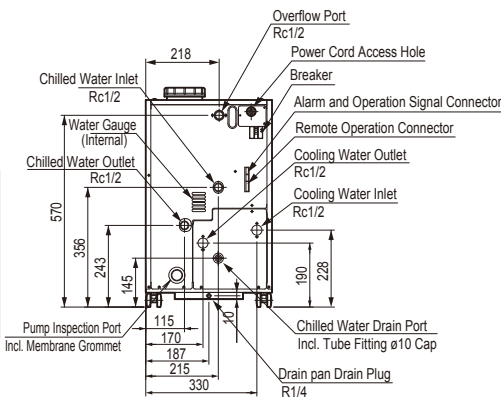
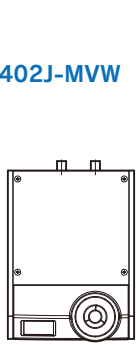

RKS401J-MV only Includes power cord with plug (3 m)
*Piping connection dimensions noted in drawings have a maximum tolerance of ±5 mm.

RKS-GM Series

Water Cooled

The ORION RKS Series Mid-Grade water cooled chillers have already been adopted in many industries. An evolution of extensive functionality in an easy-to-use design.

Mid-Grade Model GM Series

Electronic expansion valve capacity control gives temperature precision to ± 0.1 °C.
High head pump (30 m* or higher) STANDARD!

*20 m on RKS750G, 50 Hz models.

Cooling Capacity (50/60 Hz):	2.2/2.5 kW _(RKS750G-MVW) 4.9/5.3 kW _(RKS1500G-MVW)
Ambient Temp. Range:	5 - 40 °C
Working Liquid Temperature:	5 - 35 °C
Temperature Control Accuracy:	± 0.1 °C



RKS750G-MVW

RKS1500G-MVW

Easy Operation

Digital Display (Measured Water Temperature and Error Display)

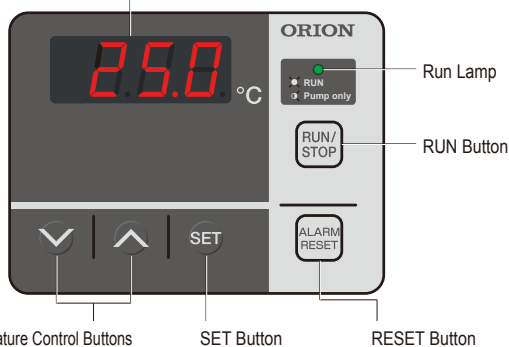

The chiller can easily be started by simply pressing the RUN button. With the breaker right in front, it's easy to switch on and off the power source. Alarms can be canceled by pressing the ALARM RESET button.

.....
Error codes of alarms that have occurred can be displayed for easy, no-worry diagnosis. Also, information on the last 6 alarms is recorded to for easier troubleshooting.

.....
Independent operation of the discharge pump is possible so that, if by some reason the compressor shuts down, water circulation can continue.

.....
Choice of Local and Remote operation can be set.

Solid

■ Sheet Metal Construction of External Surfaces

Sheet metal constructed exterior that can withstand the long life of this chiller.

■ Frame Construction

A sturdy construction that gets its rigidity from its frame design.

■ High Capacity Water Tank

The 10 L high-capacity water tank is designed to deal with liquid temperature fluctuations better.

Operation and Monitoring Via PC Possible

[Communications Method]
USB: 1 Port, RS-422A: 32 Units

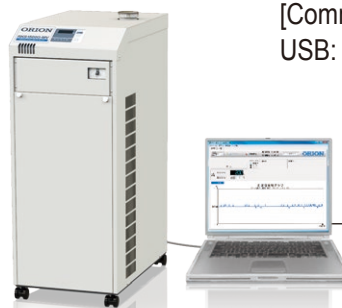

Items that can be controlled via PC:

- Starting and stopping of individual chiller units.
- Individual operation of chiller discharge pumps.
- Liquid temp. control of individual chillers.

Specifications Chart

Model		RKS750G-MVW		RKS1500G-MVW		
Performance Specifications	Cooling Capacity (50 Hz/ 60 Hz) ^{*1}	kW		4.9 / 5.3		
	Heating Capacity (50 Hz/ 60 Hz) ^{*5}	kW		1.2 / 1.4		
	Operable ambient temperature range	°C		5 - 40		
	Operable Temp. Range (Liquid Temp.)	°C		5 - 35		
	Operating Water Pressure	MPa		0.05 - 0.2 / 0.3 (50 / 60Hz)		
Power Specifications	Control Precision ^{*4}	°C		±0.1		
	Min. Operating Circulation Rate (50/60 Hz)	L/min		10 (Head20 / 30m) 12 / 21 (Head: 50m)		
	Power Source ^{*2}	V(Hz)	Three-phase 200±10 % (50 / 60)	Three-phase 220±10 % (60)	Three-phase 200±10 % (50 / 60)	Three-phase 220±10 % (60)
	Power Consumption (50/60 Hz) ^{*11}	kW	0.9 / 1.1	1.1	1.8 / 2.2	2.2
	Electric Current ^{*1}	A	3.9 / 3.7	3.7	6.7 / 7.2	7.2
Operation Control Method	Power Capacity ^{*3}	kVA		3.9		
	Breaker Capacity	A		15		
Electronic expansion valve capacity control						
Equipment Details	Compressor Construction		Fully sealed rotary type			
	Compressor Output		kW		1.8	
	Condenser		Plate type heat exchanger			
	Heat exchanger Construction		Plate type heat exchanger			
	Heat exchanger Material		SUS316 (Brazing: Cu)			
Discharge pump	Construction		Cascade type			
	Output		kW		0.4	
Water tank capacity		L		approx.10		
Refrigerant		R-410A				
Charged Amount		kg		0.46 0.59		
External Dimensions (H × D × W)		mm		615 × 500 × 375 933 × 590 × 375		
Product Mass (Dry weight)		kg		55 85		
Operating Noise Level ^{*6}		dB		59 / 62 64 / 65		

*1 Operating conditions: Chilled water temp.: 20 °C, Ambient temp.: 25 °C. Cooling capacity is at least 95% of listed figures. *2 Source voltage phase unbalance should be less than ±3 %. *3 The figure noted is when operating at the highest capacity in the normal operating range. *4 When the current load is continuously within ±10 %, and the ambient temperature is stable. However does not include starting times. *5 Maximum heating power when: Chilled water temperature: 20 °C, Ambient temperature: 25 °C, Discharge pump and head at maximum. Power will change depending on operating conditions. *6 Operating noise levels are from a position of 1 m in front of the product and at a height of 1 m.
Note 1: Liquid (chilled water) that can be used are either clean water and a 30 to 40% ethylene glycol solution. Note that there will be a drop in cooling capacity of 10% if using a 30 to 40% ethylene glycol solution. Alternatively, if deionized water is to be used, it should have an electrical conductivity of at least 1 µS/cm. **Note 2:** Do not use aluminum parts for parts that will be wetted with the chilled water. Electrolytic corrosion of aluminum can cause clogging in the heat exchanger. **Note 3:** Heat output from the unit (in kW) is approx. 1.3 times that of the cooling capacity.

Cooling Capacity

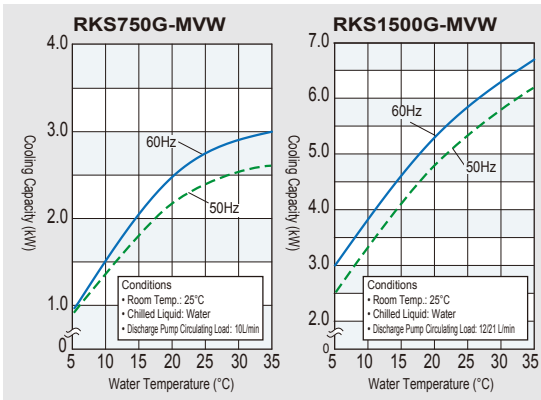

Pump Characteristic Curves

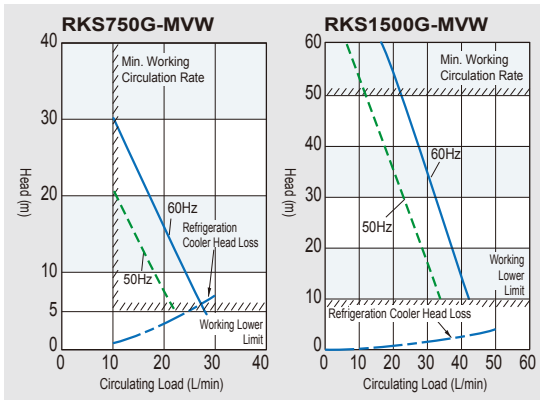

Cooling Water Flow Rate (for condenser)

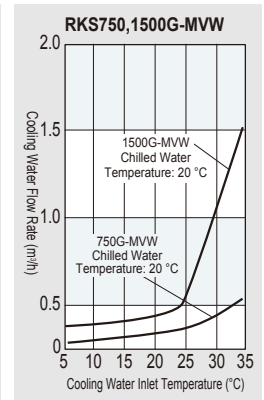

When choosing a cooling tower, use the chart to the right as a reference guide and consult with your dealer or other qualified person regarding the specific choice.

	Typical Cooling Water Flow Rate (m³/h)	Cooling Tower Capacity (kW)	Cooling Water Circuit Head Loss
RKS750G-MVW	0.6	at least 4.5	10 m
RKS1500G-MVW	1.5	at least 11.1	10 m

External Dimensions (Units: mm)

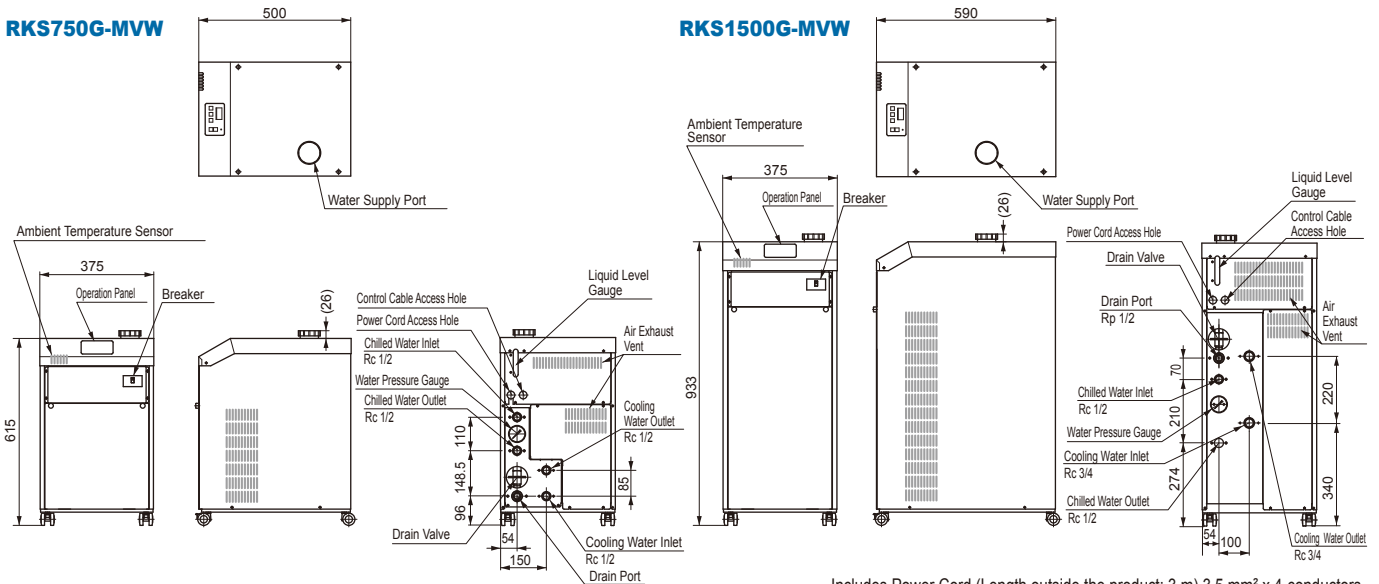

Includes Power Cord (Length outside the product: 3 m) 2 mm² x 4-conductors

Includes Power Cord (Length outside the product: 3 m) 3.5 mm² x 4-conductors
 Piping connection dimensions in the illustration have a maximum tolerance of ±2 mm.

RKS-J Series

New Model Compact Chiller No. 1 Performer in a Compact Body

Economy Model J Series

Easy to Use + Simple + Affordable

Cooling Capacity (50/60 Hz): **2.2/2.5 kW**_(RKS753J-V)
4.9/5.3 kW_(RKS1503J-V)

Operable Ambient Temperature: **10 - 40 °C**

Working Liquid Temperature: **15 - 35 °C**

Temperature Control Accuracy: **±2.0 °C**

Compressor ON/OFF control offers temperature control of ±2 °C for superior versatility.

High Pressure Pump Built In!



RKS753J-V

RKS1503J-V

Specifications Chart: Standard Models

Model	RKS-J Series			
	753J-V	1503J-V		
Cooling Capacity (50/60 Hz)	*1 kW	2.2 / 2.5	4.9 / 5.3	
Heating Capacity (50/60 Hz)	*1 kW	—	—	
Ambient Temp. Range	°C	10 - 40		
Operating Temp. Range (Liquid Temp.)	°C	15 - 35		
Operating Water Pressure	MPa	0.05 - 0.2 / 0.3 (50/60 Hz)	0.1 - 0.5	
Control Precision	*4 °C	±2.0		
Min. Operating Circulation Rate (50/60 Hz)	L/min	10 (Head: 20 / 30 m)	12 / 21 (Head: 50 m)	
Power Source	*2 V(Hz)	Three-phase 200 (50/60) 220 (60) ±10%		
Power Consumption (50/60 Hz)	*1 kW	0.9 / 1.1, 1.1	1.8 / 2.2, 2.2	
Electric Current (50/60 Hz)	*1 A	4.1 / 4.1, 4.1	6.8 / 7.4, 7.4	
Power Capacity	*3 kVA	2.0	4.2	
Breaker Capacity	*5 A	10	15	
Operation Control Method	Compressor ON/OFF Control			
Compressor	kW	Fully Sealed Rotary Type		
		0.85	1.8	
Condenser	Corrugated Fin and Tube Parallel Flow			
Evaporator	Construction	Plate Type Heat Exchanger		
	Material	SUS 316 (Brazing: Cu)		
Discharge Pump	Construction	Cascade Type		
	Output	kW	0.25	0.4
Water Tank Capacity	L	Approx. 17		
Refrigerant	R-410A			
Charged Amount	kg	0.35	0.55	
External Dimensions (H × D × W)	mm	615 × 500 × 375	933 × 590 × 375	
Product Mass (Dry weight)	kg	45	67	
Export Standard CE and UL (60 Hz only)	—			
Operating Noise Level	*6 dB	61 / 63	63 / 66	

*1 Under the following conditions: Chilled water temp.: 20 °C, Ambient temp.: 25 °C, Max. discharge pump circulating load. Cooling capacity is at least 95 % of listed figures. Heating capacity will change according to operating conditions.
 *2 Source voltage phase unbalance should be less than ±3 %. *3 The figure noted is when the equipment is operating at the highest capacity of its normal operating range. *4 When the current load is continuously within ±10 %, and the ambient temperature is stable. However does not include starting times or when the heat-load exceeds the chiller capacity.
 *5 Comes standard with a built-in overload protection circuit breaker (NFB). *6 Operating noise levels are from a position of 1 m in front of the product and at a height of 1 m.
 Note 1: Liquid (chilled water) that can be used are either clean water and a 30 to 40% ethylene glycol solution. Note that there will be a drop in cooling capacity of 10% if using a 30 to 40% ethylene glycol solution. Alternatively, if deionized water is to be used, it should have an electrical conductivity of at least 1 μS/cm.
 Note 2: Do not use aluminum parts for parts that will be wetted with the chilled water. Electrolytic corrosion of aluminum can cause clogging in the heat exchanger.
 Note 3: Heat output from the unit (in kW) is approx. 1.3 times that of the cooling capacity.
 Note 4: Depending on the operating environment, condensation may form on piping inside the product, and temporary leakage of water from the pump mechanical seals may also occur, therefore a drain pan should be installed if required.

Cooling Capacity

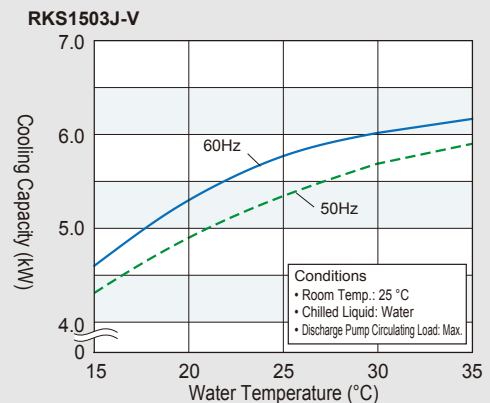
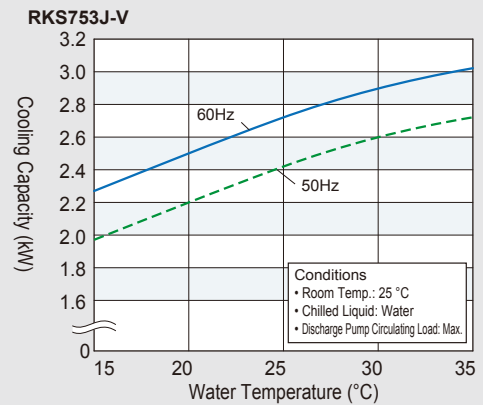

Discharge Pump Characteristic Curves

Operating Temp. Range

RKS753J-V

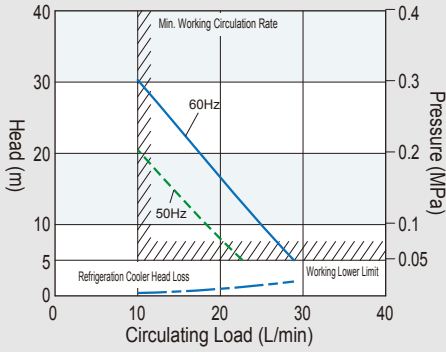

RKS1503J-V

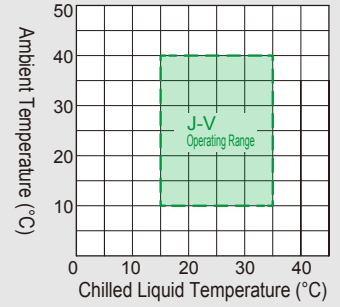
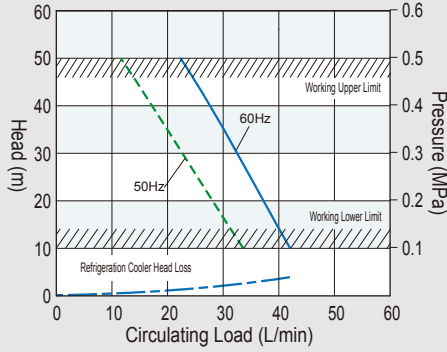

Discharge Pump Characteristic Curves (For factory options)

High Head / High Flow-Rate Pump
For RKS753J-V

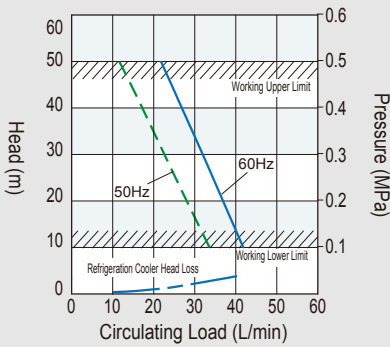

Pump w/Copper-Less Spec. Wetted Parts
For RKS753J-V

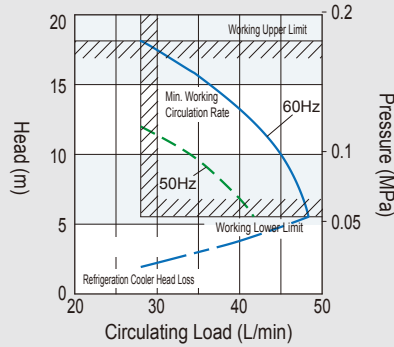

Pump w/Copper-Less Spec. Wetted Parts
For RKS1503J-V

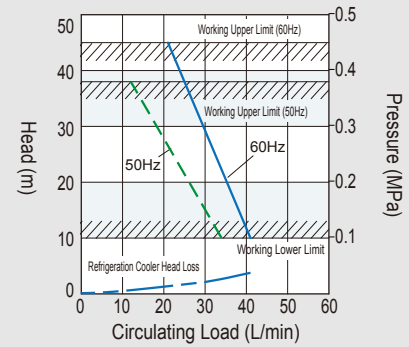

External Dimensions (Units: mm)

RKS753J-V

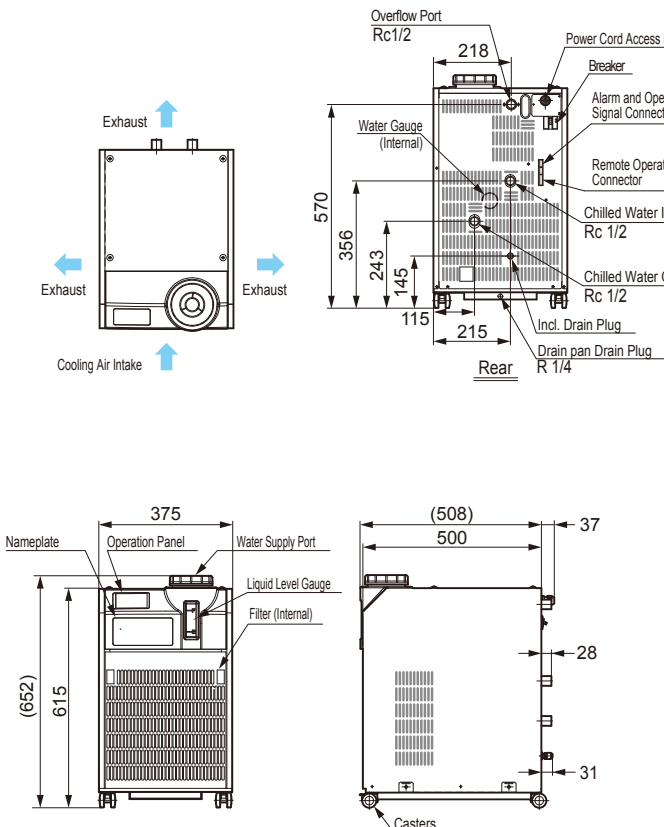

RKS1503J-V

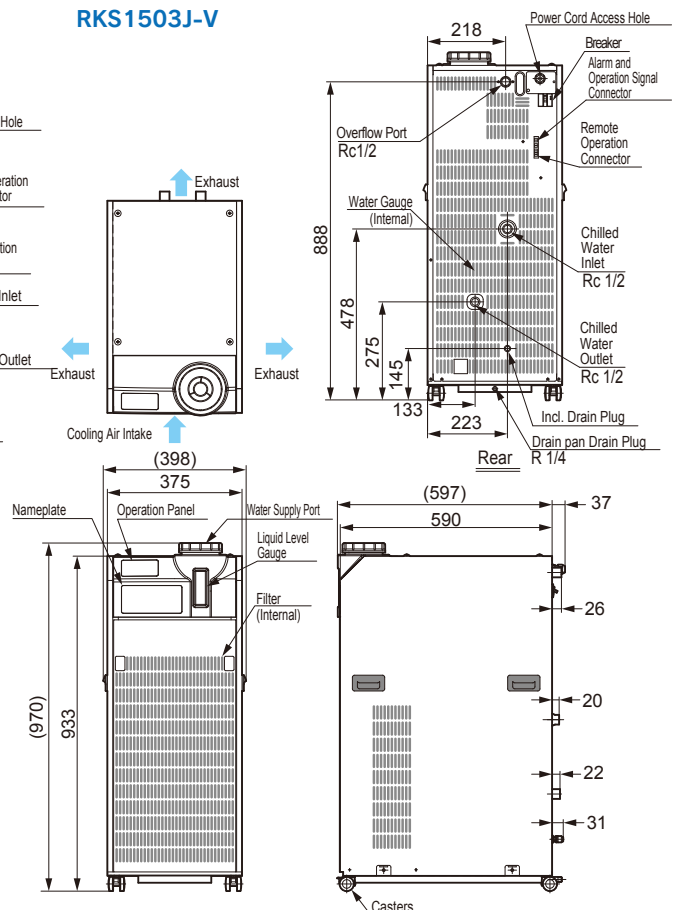

*Piping connection dimensions noted in drawings have a maximum tolerance of ± 3 mm.

Manufacturer Options and Accessories



Many Functional Specifications Available to Match Your Application

Factory Option Designation Description

Model : **RKS401J-MV-00000**

① Model 40 Compressor Output Rating: 400 Class 70 Compressor Output Rating: 750 Class 150 Compressor Output Rating: 1500 Class	② Power Source 1 Single-Phase 100 V *1 2 Single-Phase 200~230 V *2 3 Three-Phase 200 V (50/60 Hz) *3	③ Model M Middle Grade Model Blank Economy Model	④ Pump / Water Circuit 0 Standard 1 High Head / High Flow-Rate *4 2 Copper-free wetted parts	⑤ Circuit Breaker 0 Standard (NFB) 1 Earth leakage circuit breaker (ELB)	⑥ External Surface 0 Surface painted steel sheet 1 Stainless steel (SUS304)
---	---	--	---	--	---

- * 1 400 class only
- * 2 J-MV Series only
- * 3 750 class and 1500 class only
- * 4 RKS402J-MV and 750 class only

Accessories Choose the Model that Best Suits Your Application. Contact us for details.

Model	Name	Qty /Unit	Description
RK-BP001	Bypass Piping Kit A	1	Quick Tube 3/8" Connector
RK-BP002	Bypass Piping Kit B	1	Rc 1/2 Pipe
RK-JB001	Compression Fitting ⁵	1	Inlet/Outlet 1/2", Brass
RK-VB001	Valve A	1	Inlet/Outlet 1/2", Brass
RK-VB002	Valve B	1	Inlet/Outlet 1/2", SUS
RK-VB003	Valve C	1	Inlet/Outlet 1", Brass
RK-VB004	Valve D	1	Inlet/Outlet 1", SUS
RK-WS001	Automatic Water Supply Kit	1	Float Valve ³
RK-LV001	Relief Valve Kit ⁶	1	Initial Setting: 0.3 MPa (Control range: 0.2 - 0.5 MPa)
RK-FR001	Flow Gauge A ¹	1	Connected Flow Impeller Type (1.5 - 20 L/min)
RK-FR002	Flow Gauge B ¹	1	Connected Flow Impeller Type (3 - 60 L/min)
RK-HF001	Water Filter Housing	1	Filter element sold separately
RK-FE001	Filter Element (5 μm)	1	
RK-FE002	Filter Element (10 μm)	1	
RK-FE003	Filter Element (25 μm)	1	
RK-FE004	Filter Element (100 μm)	1	
RK-CA001	Power Cable ⁶	1	For RKS402J-MV (W) 3 m For RKS752J-MV 3 m
RK-CA002	Power Cable ⁶	1	For RKS753J-V • MV 3 m For RKS1503J-V • MV 3 m
RK-CA003	Power Cable ⁶	1	For RKS1502J-MV 3 m
RK-TH001	Differential Temperature Control Thermistor ¹	1	Cable: 5 m
RK-HI001	Water Startup Heater Kit ¹	1	Single-Phase 200 V, Capacity: 0.5 kW / for RKS402
RK-HI002	Water Startup Heater Kit ¹	1	Single-Phase 200 V, Capacity: 1 kW / for RKS750
RK-HI003	Water Startup Heater Kit ¹	1	Single-Phase 200 V, Capacity: 2 kW / for RKS1500
RK-EB001	Remote Communications Interface	1	Connect external RS422 and RS485 accessories.
RK-DI001	Electrical Conductivity Control Kit A ¹	1	Bracket, deionizer, solenoid valve, electrical conductivity meter (10 - 500 μS/cm)
RK-DI002	Electrical Conductivity Control Kit B ¹	1	Bracket, deionizer, solenoid valve, electrical conductivity meter (1 - 20 μS/cm)
RK-DI003	Deionizer Kit	1	Deionizer, valve
RK-DI004	Electrical Conductivity Meter A ¹	1	Electrical conductivity meter (10 - 500 μS/cm)
RK-DI005	Electrical Conductivity Meter B ¹	1	Electrical conductivity meter (1 - 20 μS/cm)
RK-RF001	Earthquake Resistance Bracket	1	Painted
RK-DP001	Drain Pan Kit ¹	1	Drain pan (SUS), float tap
RK-DP002	Drain Pan	1	Drain pan (SUS)
RK-TR001	Transformer Kit	1	Three-phase 380 - 400 V (for three-phase models)
RK-YS001	Y-Strainer Kit A ⁶	1	40 mesh 1/2" brass
RK-YS002	Y-Strainer Kit B	1	40 mesh 1/2" SUS
RK-EY001	Eye Bolt Kit	1	Incl. M8×4 rubber washers

Bypass Piping Kit ²



Chilled water flow and pressure controllers are indispensable.

Automatic Water Supply Kit ³



Ball tap installed inside the tank. Trouble-saving water-supply kit.

Relief Valve Kit



Indispensable when you don't want the chilled water circuit pressure to be higher than necessary.

*Flow Gauge A(B)



Can be used to monitor the chilled water circuit flow rate.

Water Filter Housing



Removes foreign material from the chilled water circuit. Choice of element. (Sold separately)

*Water Startup Heater Kit



Separate standing startup heater. Can also be used for control purposes.

*Remote Communications Interface



Accessories marked with *mark are compatible with this expansion board.

Earthquake Resistance Bracket



Mount your chiller to the floor to prevent it from tipping over.

*Drain Pan Kit



Prevents damage in case of incidental water leaks. The chiller is placed in the drain pan and secured in place.

*Electrical Conductivity Control Kit A(B)



Allows for purity management of circulating water. (Photo: Seen attached to the bypass circuit.)

- *1: Items marked with a * require installation of the RK-EB001 communications interface. The communications expansion board must be present when these accessories are to be used.
- *2: Model numbers ending with -2**00 indicate models that include bypass piping in the chiller.
- *3: The water tank cannot be directly connected. Please supply water using a prepared water supply tank or cistern.
- *4: The Water Startup-Heater Heater Kit requires its own single-phase 200 V power supply.
- *5: While we do sell individual accessories, please contact your dealer if you want to purchase individual parts used with accessories.
- *6: Not RoHS compliant (Please consult your dealer for compliant models.)

All photographs show optional equipment installed. These items require that the user assemble (and attach) these products. (All accessories include an installation instructions.)

Examples of Needs-Based Accessory Set-Ups

Remote Communications Interface to Meet Your Various Needs

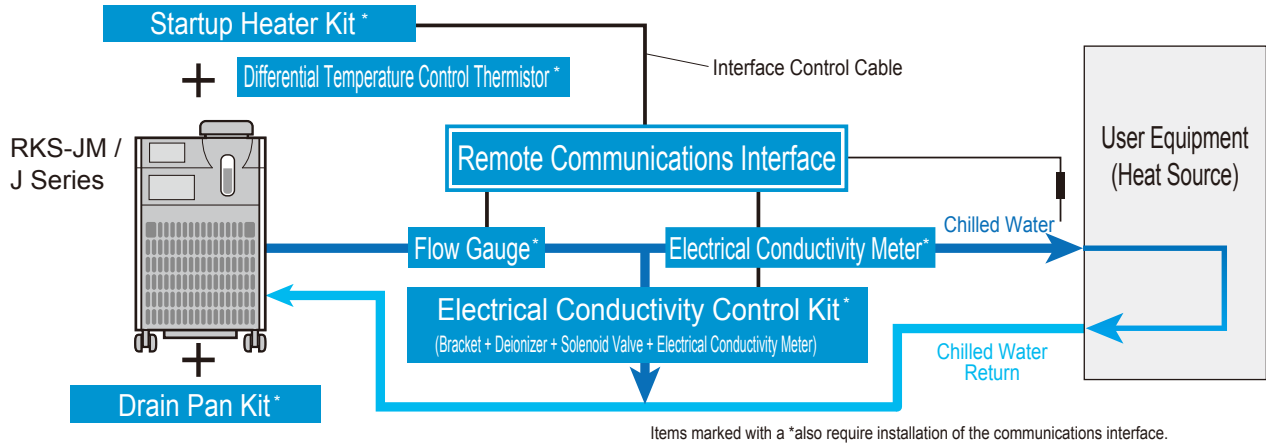

Industry Recommended Accessories that Meet Your Needs

• For the Laser Industry

[Additional Accessories]

Remote Communications Interface •
Electrical Conductivity Control Kit • Relief Valve •
Water Filter Housing



Flow rate and pressure control to meet specs. for an oscillator or optical system. Choose a filter to keep foreign substances off your laser head. Chilled water purity is also maintained.

• For Liquid Crystal • Semiconductor Industries

[Additional Accessories]

Remote Communications Interface •
Electrical Conductivity Control Kit • Bypass Piping Kit •
Drain Pan Kit



Management of chilled water. Be prepared for water leaks with a drain pan and float switch. A factory option copperless spec. unit suitable for use with an aluminum circuit.

• For Research • Development • Inspection Industries

[Additional Accessories]

Remote Communications Interface • Flow Rate Meter •
Water Filter Housing • Bypass Piping Kit •
Differential Temperature Control Thermistor



Flow rate management to X-ray source, or LED-UV. Choose a filter to keep foreign substance out of the chilled water circuit. Work-stage temperature control (cascade control) possible.

• For Machine Tooling

[Additional Accessories]

Remote Communications Interface • Bypass Piping Kit •
Differential Temperature Control Thermistor



Condensation prevention that tunes the chilled water temperature in conjunction with the external temperature (differential temperature control). Pressure and flow rate tuning via bypass control.

Manufacturer Accessories

RKE and RKS Series
Common with All Models

Ion Exchange Resin Purifying Equipment

Cartridge type and filter type for easy connections. It's easy to supply deionized water.

For circulating water setups.

Can prevent rises in electrical conductivity in the circulating water when installed in a bypass circuit within the chilled water circulation circuit.

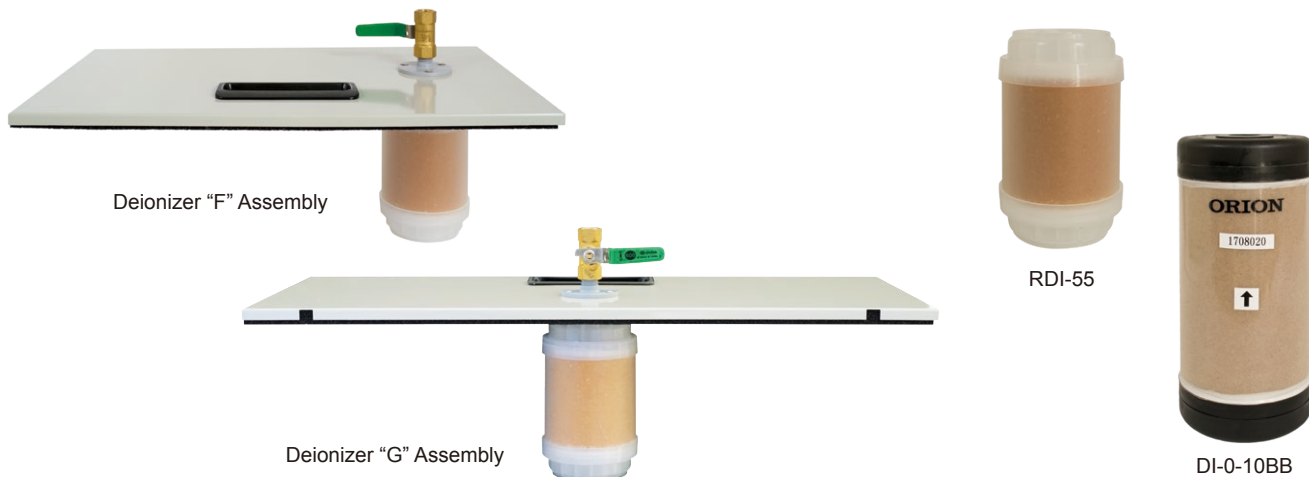

Model	Deionizer "F" Assembly	Deionizer "G" Assembly	Deionizer "H" Assembly		Deionizer Kit RK-DI003	
Part Number	04101157010	04103028010	04106210010	04106210020	04106501010	04106501010
Applicable Models	RKE750A1-V RKE1500B1-V RKE1500B1-VW	RKE2200B-V RKE2200B-VW	RKS750G-MVW	RKS1500G-MVW	RKS401J-MV RKS402J-MV RKS402J-MVW RKS752J-MV RKS753J-MV RKS753J-V	RKS1502J-MV RKS1503J-MV RKS1503J-V
Ion Exchange Resin	RDI-55		DI-0-10BB		RDI-55	
Ion exchange resin part number	0A001386000		0A001108000		0A001386000	
Purification Capacity	L	Approx. 55	Approx. 600		Approx. 55	
Water Quality	µs/cm		10 or lower			
Working Water Pressure	MPa		0.05 – 0.2			
Working Water Temperature	°C		5 – 40			
Dimensions	ø74.5-H122mm (Ion Exchange Resin)		ø185-364mm		ø74.5-H122mm (Ion Exchange Resin)	
Mass	g	Approx. 270 (Ion Exchange Resin)	Approx. 5700		Approx. 270 (Ion Exchange Resin)	
Type of Installation	Under the upper cabinet panel		Rear of Product		Rear of Product	
Inlet/Outlet Piping Fixtures	—					
Included Parts	Preliminary Deionizer *3, Upper Cabinet Panel, Ball Valve		Deionizer, Caster Mounting Bracket, Deionizer Inlet/Outlet Piping x 2 pcs, Special DI Hardware, Ion Exchange Resin, Hex Socket Head Bolt x 2 pcs, Chilled Water Inlet/Outlet Piping x 2 pcs, Two types of Nylon Tube x 1 each, Insert-Ring x 4 pcs		Deionizer, Deionizer Kit Installation Guide, Barrel Nipple 1/4", Barrel Nipple 1/2" x2 pcs, Unequal Tee Joint 1/2"x1/4"x2 pcs, Ball Valve 1/4", One-Touch Fitting - Straight 1/4" (Tube Diameter4mm), One-Touch Elbow Coupling 1/4" (Tube Diameter4mm)x3 pcs, Clear Polyurethane Tube 4mm850mm x2 pcs, Insert-Ring x 4 pcs, Nylon Cable Tie x2 pcs, Specifications Label	

*1 Purification capacity figure based on water source standard purity level of 150 µS/cm. Capacity may vary according to water quality.

*2 The purification capacity does not indicate the volume of water at the intake during circulation. Ion exchange resin lifespan and water quality will change depending on the material of wetted parts and wetted surfaces, as well as the installation environment, etc.

*3 It is recommended that the initially supplied water be either water that has been purified by having passed through an ion exchange resin, or be commercially purchased deionized water or the like. If tap water (or a similar grade of water) is used, the effective life of the ion exchange resin will be greatly reduced. In such cases, please replace the ion exchange resin soon.

Caution) Avoid installing the ion exchange resin where it will be in direct sunlight or in places where there is a risk of it being damaged.

Introducing the ORION IoT System

Remote Monitoring & Remote Operation of ORION Products.

Uses your factory's internal network for safety against leaks of internal information.

Compatible Models

RKE (-B) Series

RKS Series



Monitoring
Communication *1



Monitoring
Communication *1

*1 : Optional communication board is required.

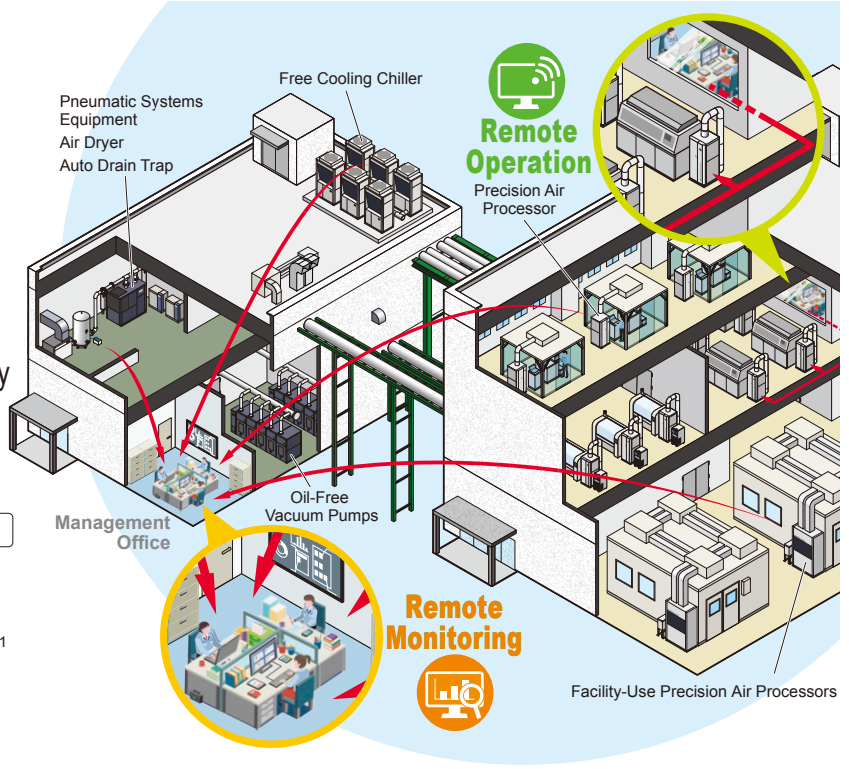

Contact-State Monitoring Software

Includes Mail-Alert Functionality

Need to walk to the site every day in order to check the operating state of your equipment...

And the constant worry that you won't be around when an alarm condition occurs!

Monitoring of product operating states from remote sites is possible. Can be used as long as contact outputs are **non-voltage contacts**. Get email alerts when alarms occur! Getting alerts while away from the PC gives peace of mind!

Checking operating states is easy! Mail alerts for alarm conditions give peace-of-mind when away from the site.

ORION Communication Software

Need to walk to the factory each time to start and stop operation...

Run/Stop operations are possible from remote locations. And temperature settings can also be changed.

Now, Run/Stop and other operations are easier!

How to Download our IoT Software

STEP 1

Visit our website.

<https://www.orionkikai.co.jp/download/iot/>

STEP 2

Confirm the download you need from the list of software.

STEP 3

Perform the registration process and enter the product model number and serial number.

Download Completed.

Note that our software is only offered in Japanese. Operation with non-Japanese operating systems has not been confirmed. Please refer to the instruction manual for required equipment and specifications.

RKE Series Important Unloading and Placement Information

⚠ WARNING = Failure to follow instructions contained in a WARNING may result in death or serious injury.

⚠ CAUTION = Failure to follow instructions contained in a CAUTION may result in injury to the operator or damage to property.

Pre-Unloading and Unloading Procedures

• Before Unloading

After unpacking, check the nameplate of the unit to ensure it is the correct model ordered. Abnormalities or other damage may occur during shipping or handling of the product. When receiving the product, check to make sure that there are no scratches or other abnormalities. If any damage or abnormality is detected, please contact the dealer where the product was purchased.

* For RKE2200B1-V/VW, check that the below mentioned included parts are present.

Included Parts			Model	
Part Name	Specifications	Qty per Unit	RKE2200B1-V	RKE2200B1-VW
Y-strainer	40 mesh equiv.	1 pc	○	○
Barrel Nipple	1B(For the Y-strainer)	1 pc	○	—
Short Pipe	1B Length100 mm(For the Y-strainer)	1 pc	—	○

⚠ WARNING

When using the optional suspension eyebolts (RKE750A1-V, RKE1500B1-V, VW), always use all 4 eyebolts and make sure there is at least a 60° angle between the top face of the product and each of the suspension cables. Improper suspension may lead to the product tipping over or falling, which could result in injury.

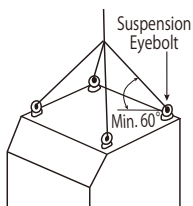

• Unloading Procedure

The unit is heavy; please be careful when transporting it. When lifting the unit by forklift or handlift, make sure the forklift/handlift tines go underneath the wooden base of the package all the way and protrude from the other side.

* There are forklift slots on the base for RKE2200B1-V, VW.

Model	Mass (Water tank empty)
RKE750A1-V-G1 (without casters)	68 kg
RKE750A1-V-G2 (with casters)	73 kg
RKE1500B1-V-G1 (without casters)	96 kg
RKE1500B1-V-G2 (with casters)	100 kg
RKE1500B1-VW-G1 (without casters)	95 kg
RKE1500B1-VW-G2 (with casters)	98 kg
RKE2200B1-V, VW-G1 (without casters)	135 kg
RKE2200B1-V, VW-G2 (with casters)	140 kg



⚠ WARNING

Installation of this product should be performed by your dealer or other qualified personnel. Improper installation by the end user may lead to water leakage, electric shock, fire or other problems.

Product Placement

• Choice of Installation Location

Choose an installation location that is free from combustible materials, areas that could lead to electric shock, or environments that could damage the product.

⚠ CAUTION

Install on a level surface that can adequately support the weight of the product and bolt it down with anchor bolts or other means in order to prevent it from moving around. Lock all casters on models that are equipped with casters. Failure to install as indicated can result in water leaks or injury etc., from the product tipping over or falling.

1. Ensure there is adequate space for heat ventilation as well as sufficient space for maintenance and inspection. If air cooled models are installed in an enclosed space as shown below, exhaust from the product can re-enter at the heat exchange air intake port which will cause the refrigerant high-pressure to increase and could cause the product to shut down.
2. If installing where a wind of 8 m/s or higher will be blown on it, measures to block the wind from hitting the product such as installation of a wind-break wall are required. (Air cooled models only.)

3. Install out of direct sunlight and do not install where the product would be affected by heat. Exposure to direct sunlight or heat can cause the product to perform below the specified performance equal to the amount of the heat exposure. It can also lead to the activation of built-in protection devices which will prevent operation.

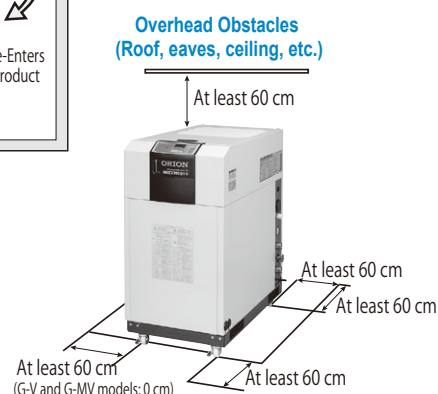
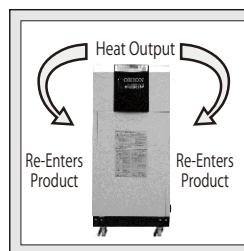

4. See the chart below for operable ambient temperatures. Operating outside the operable ambient temperature range can result in compressor breakdown, reduced cooling capacity, and can cause the product to stop operating due to activation of built-in safety devices.

Ambient Temp.	Model
-5 – 43 °C	RKE750A1-V, RKE1500B1-V, RKE2200B1-V
2 – 43 °C	RKE1500B1-VW, RKE2200B1-VW

5. If ducting is to be installed, have the installation performed by a qualified professional.

Fan Air Flow (m ³ /min) 50/60Hz	Model		
	RKE750A1-V	RKE1500B1-V	RKE2200B1-V
	26	37 / 41	50 / 60

6. Install in a place that is generally free of dust and dirt. Installation in places with heavy dust and dirt can result in reduction in performance.

7. Condensation on internal piping or leakage from the water pump may occur depending on the operating environment.

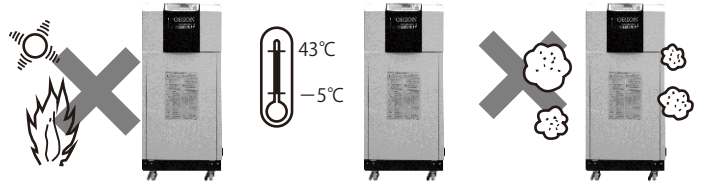

*Model RKE2200B1-V shown.

⚠ WARNING

Installation of this product should be performed by your dealer or other qualified personnel. Improper installation by the end user may lead to water leakage, electric shock, and fire.

Water Supply and Drainage Construction

- Reliably install water supply and drainage piping. Improper water supply and drainage construction could result in water spraying out, causing water damage to the surrounding area.
- Ensure that the water supply pressure is 0.50 MPa or lower. Too high a pressure can damage the product and may lead to water leaks, flooding of the surrounding area, and electric shock.
- Keep the cooling water pressure below 0.69 MPa. Higher pressure may damage the components to cause water leakage and may result in electric shock.
- When performing water piping, be careful to avoid the following points. Failure to do so can result in water leakage.

1. Overtightening the piping connected to the water supply port.
 2. Having external forces on the water supply port.
 3. Piping installation that does not absorb vibrations of water hammer, etc.
- When connecting piping to the water supply port, always use two tools, using one to support the ball tap valve. *The ball tap valve is optional equipment.
 - Do not block the overflow piping. Blocked piping can cause water leakage inside the chiller.
 - Condensation on internal piping or leakage from the water pump may occur depending on the operating environment. Install a drain pan as needed.

Chilled Water / Cooling Water Piping

•Piping Sizes

Piping diameters for each model are listed below.

Piping Item	Model	RKE750A1-V	RKE1500B1-V	RKE1500B1-VW	RKE2200B1-V	RKE2200B1-VW
	Chilled Water Inlet	Piping Size	Rc1/2	Rc1		
Tightening Torque		29.4	39.2 N • m or less			
Chilled Water Outlet	Piping Size	Rc1/2	Rc1			
	Tightening Torque	29.4	39.2 N • m or less			
Water Tank Drain (Overflow)	Piping Size	Rp 1/2				
	Tightening Torque	29.4 N • m or less				
Drain Pan Drain Port	Piping Size	R 1/4				
	Tightening Torque	19.6N • m or less		20.0 N • m or less		19.6 N • m or less
Water Supply Port	Piping Size	Rc 1/2				
	Tightening Torque	39.2 N • m or less				
Cooling Water Piping Inlet	Piping Size	–	–	Rc 3/4	–	Rc 3/4
	Tightening Torque	–	–	39.2 N • m or less	–	39.2 N • m or less
Cooling Water Piping Outlet	Piping Size	–	–	Rc 3/4	–	Rc3 /4
	Tightening Torque	–	–	39.2N • m or less	–	39.2 N • m or less
Cooling Water Drain Port	Piping Size	–	–	Rc 1/4	–	Rc 1/4
	Tightening Torque	–	–	20.0 N • m or less	–	19.6 N • m or less

●Piping Methods

Piping installation should follow the guidelines printed below.

1. Check the chilled water inlet and outlet side ports.
2. Make pipe lengths as short as possible, and also avoid vertical and curved piping as much as possible.
3. When tightening piping connections, use 2 pipe wrenches or adjustable wrenches in order to grasp both sides of the joint.
4. If required, a (user provided) bypass valve or drain valve should be installed on the cooling water inlet port in order to ensure the minimum circulating water flow rate.
5. For RKE2200B1-V/VW, install the included Y-strainer on the chilled water intake side port.
6. Make sure that there is not excessive weight or vibration on the product from the connected piping. Longer lengths of horizontal piping should be supported with additional support hardware or by other means to ensure unreasonable forces are not applied directly to the product's connection ports. Failure to properly support piping can lead to equipment damage.
7. Always insulate piping. (Allow enough space between insulated pipes so that the lower right cabinet panel can be removed, and to allow operation of the bypass valve. Also make sure that the water pressure

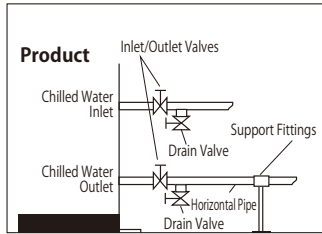

*Model RKE750A1-V, RKE1500B1-V, VW shown.

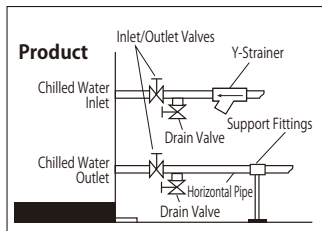

*Model RKE2200B1-V, VW shown.

gauge will be visible after installation.)

8. Install the optional Float Valve Assembly if an automatic water supply system is to be constructed. Keep water supply pressure at or below 0.50 MPa.
9. Install reliable overflow piping in order to avoid water splatter.
* Do not install piping higher than the overflow port.

●Cooling Water Piping (Water cooled model)

1. Confirm the positions of the cooling water inlet and outlet ports. Confirm the position of the cooling water inlet and outlet ports by checking warning label on the product.
2. Follow the instructions below for piping work.
 - (1) Mount the Cooling Water inlet valve ① and the Cooling Water outlet valve ②.
 - (2) Be sure to mount the safety relief valve ③. The regulating valve that is installed in the cooling water circuit performs the opening and closing of the valve automatically by detecting the refrigerant pressure. Thus, there is a possibility that the regulating valve becomes full-closed during operation. Be sure to install the safety relief valve for the water leakage prevention in the cooling water circuit, and set the cooling water inlet pressure 0.69 MPa or lower.
 - (3) Install the purge/drain valve ④.
 - (4) Be sure to install the union coupling ⑤. Make sure that it can easily disassemble the product and cooling water piping when carrying out the cleaning of water-cooled condenser in inside the product.
 - (5) Install a Y-strainer before the cooling water intake port.

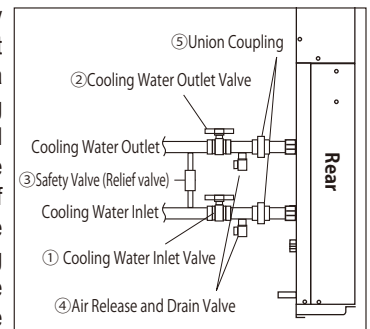

Electrical Wiring

●Correct Wiring Installation

When performing electrical wiring, be sure to carefully follow the guidelines listed below.

1. Choose a power cable based on the breaker capacity shown in the table on the page 21. Always properly hook up the ground wire to the earth (ground).
2. Wire the product independently with its own overload protection multi-purpose earth leakage breaker.
*There is a combined use overload protection and earth leakage breaker installed for RKE2200B1-V, VW only.
3. Route the power cord through the power cord access hole, located on the lower-right part of the unit, to the inside of the terminal box. (Use 1 of the 2 available power cord access holes. The other can be used for remote control panel connections, etc.)
4. Always properly ground this unit. Connect the ground wire to a proper earth/ground point that has been installed by a qualified electrician.
5. Ensure the source voltage is within $\pm 10\%$ of the specified voltage. Also make sure the source voltage phase unbalance * is within $\pm 3\%$.

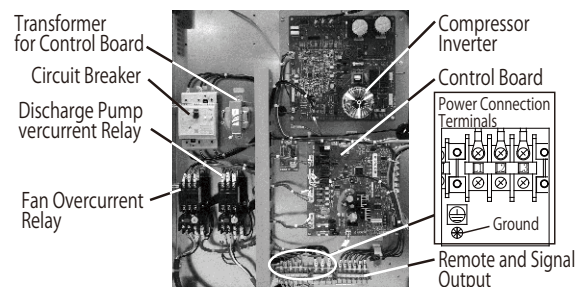

*Model RKE2200B1-V shown.

$$*Phase\ unbalance\ (\%) = (Maximum\ voltage\ [V] - Minimum\ voltage\ [V]) \div Average\ voltage\ of\ 3\ phases\ (V) \times 67. \text{ (Based on IEC61800-3.)}$$

The current setting of the discharge pump overcurrent relay (THR) needs to be changed depending on the operating conditions. (RKE1500B1-V, VW)

Frequency	Discharge Pump Pressure Value	
	Less than 0.39MPa	0.39 – 0.5MPa
50Hz	2.3 A (Default value)	2.3 A (Default value)
60Hz	2.3 A (Default value)	2.6 A (Changed value)

*When operating in areas with 60 Hz power, with a discharge pump pressure of 0.39 MPa or higher, the overcurrent relay (THR) current setting should be changed from 2.3 A to 2.6 A.

Model		RKE750A1-V	RKE1500B1-V RKE1500B1-VW	RKE2200B1-V	RKE2200B1-VW
Power Source (V · Hz)		Three-phase 200 · 50/60			Three-phase 220 · 60
Maximum Operating Current (A)		6 (Heater installed 11)	11 (Heater installed 16)	19	16
Terminal Block	Screw Size	Power Source	M3.5	M4	
		Ground	M4 Tapping (w/toothed lock washer)		
	Terminal Block Width (mm)	Power Source	7.5	10	
		Signal	7.5		

Model	RKE750A1-V	RKE1500B1-V RKE1500B1-VW	RKE2200B1-V RKE2200B1-VW
Breaker Capacity (A)	10 (Heater installed 15)	15 (Heater installed 20)	30 (Built-in)
Current Sensitivity (mA)	30 (High-speed model)		30 (Built-in)

If Employing Remote Control Operation

Information Regarding Remote Operation and Communications Functions

Perform the wiring after first confirming the required specifications.

*Please prepare terminals that fit M3 size screws.

1. Please confirm the unit specifications which are as follows.

Remote Operation Input Specifications	No-voltage contacts input (Alternating switch) Maximum cable length: 20 m Input power resistance 1200 Ω Open circuit voltage (Voc) 12 VDC Short circuit current (Isc) 10 mADC
Signal Output Specifications	No-voltage relay contact output (c contact) 250 VAC / 30VDC 5 A (Resistive load) (Normal Open) 250 VAC / 30VDC 3 A (Resistive load) (Normal Close) Minimum operating current (For reference only) 5 VDC 10 mA

2. Remote operation and signal output terminals are as follows:

	RKE750A1-V, RKE1500B1-V, VW, RKE2200B1-V, VW	
Remote Operation Contacts	Remote Operation	17 18
Signal Output Contacts	Operation Signal	13 Close at operation 14
	Alarm Signal	15 Close at alarm 16

[IMPORTANT]

■ Make sure the power cord does not come into contact with the motor or refrigerant piping within the product. Contact with hot surfaces could cause the cord to melt, resulting in an electrical short. (Secure power source wiring inside the distribution panel with cable ties.)

■ Never allow the product to run dry. Always fill the water tank and confirm the water level before operating.

■ Do not perform withstand voltage tests nor insulation resistance tests on this product. Doing so can damage the semiconductors used in the chiller control board or inverter. If the tests are deemed necessary, please consult your dealer.

When Using Communications Function

1. RS-232C

(1) Connector: D-sub 9 pin female connector

(2) Maximum data cable length: 15 m*

*May differ depending on specific operating conditions.

2. RS-422A(RS-485)

(1) Connector: Terminal block

(2) Cable Gauge: AWG16 - 26

(Use AWG18 - 24 if 2 wires are to be inserted into a single terminal connection.)

(3) Length of Insulation to Remove From Cable: 10 mm

(4) Attaching the Cables: Use either of the following methods: Attach the stripped wires as is. When performing hookups, be careful not to allow frayed wires to come into contact with or short out nearby wiring.

(5) Maximum Cable Length: 100 m or less - - May differ depending on operating conditions.

*If connecting via RS-422A/485, make the connection by purchasing and using an RS-232C/422A converter.

(6) Connection Example

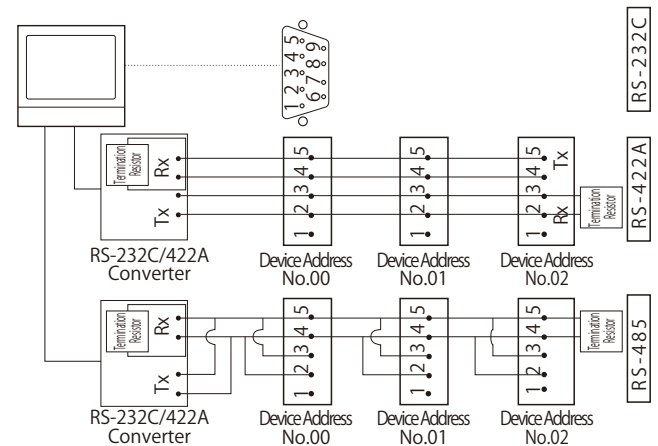

* Model RKE2200B1-V shown.

Ducting Design Points (Air cooled only)

●Ducting Design Points (For User-Installed Ducting)

If the installation area is narrow or has a low ceiling, the ambient temperature could raise to above 45 °C from heat coming from the ventilation outlet on the product. In such cases, ducting should be used to move the heat outside of the room or at least away from the product so that the effects of it do not cause the temperature near the product to rise. Take the following into consideration when planning duct work.

1. Duct Cross Sectional Area

(1) For ducting that rises up:

Model	RKE2200B1-V
Minimum Cross Sectional Area (m ²) [B×W]	0.21
Maximum Length (m)	20

(2) Rectangular ducting with bends:

- The cross sectional area should be greater than what is noted above, and the length of Lx and Ly should be less than 2 m. (See Fig. 1)
- If the length of Lx and Ly go over 2 m, then there should be a 20 cm

[IMPORTANT]

If ducting is to be affixed to the unit, first remove the suspension eyebolts from the top and replace them with M size bolts of the appropriate size. Ensure that there is no obstruction in the direction of the exhaust air flow within 2 m of the product. Failure to follow this rule will result in decreased air flow and insufficient heat ventilation, which can cause built-in safety devices to activate and stop operation of the product.

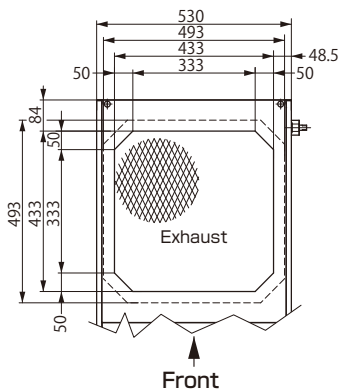

gap between the hot exhaust air outlet from the unit and a fan should be installed on the duct outlet.

Do not allow Lx and Ly to be longer than 5m. (See Fig. 2.)

*The duct in the figure is one example. The particular direction the duct exhaust port goes from the unit does not matter, however the following important points must be enforced.

Fig. 2 Installation method when Lx and Ly are longer than 2 m.

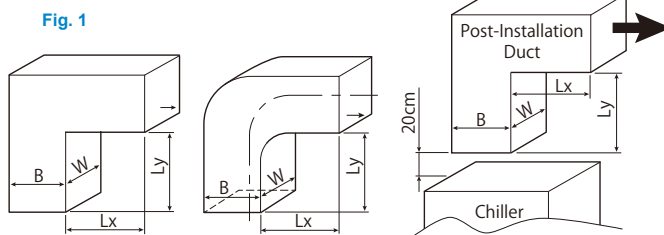

●Take the following into consideration when planning duct work.

Fan Model	Recommended Fan	Minimum Required Air Flow (m ³ /min)	
		Power Source 50Hz	Power Source 60Hz
RKE750A1-V	Consult a qualified professional for installation.	26	
RKE1500B1-V	Consult a qualified professional for installation.	37	41
RKE2200B1-V	EF-35DTB3-(Q) (MITSUBISHI)	50	60

Points to Follow to Achieve Performance Specifications

●Important Points to Ensure Optimum Product Performance

- Note the operating ranges and always operate the product within these ranges. Operating outside the designated ranges can damage the product.
- Do not use aluminum parts for parts that will be wetted with the chilled water or cooling water. The chilled water and cooling water circuits operate with parts made of copper or copper alloys, so if user-installed wetted parts containing aluminum are present, the resulting copper ions will lead to electrolytic corrosion and copper deposits, which can cause water leakage around mechanical seals and clogging in the heat exchanger.
- Please consult your dealer before using any corrosion inhibiting water additives. Troubles such as the water becoming dirty, or damage to the refrigeration unit from clogging etc. can result depending on the type of additive used.
- Operating with antifreeze rust inhibitor additives can reduce the lifespan of the mechanical seals.

[IMPORTANT]

■Do not operate with the discharge pump water circuit (chilled water inlet and outlet ports) blocked. Operating with the circuit blocked can result in freezing or damage to the condenser, breakdown of the discharge pump, or disconnection of hoses.

■When using anti-freeze brine solution, a 30 to 40% solution of industrial use ethylene glycol is recommended. However, if operating under the following conditions, it is possible that it may go bad. Therefore, in such cases, depending on the water temperature, anti-freeze operation through automatic operation of the pump is recommended.

- If the water temperature does not go below 20 °C even when the product is stopped.
- If the water in the water tank has not been replaced in over 3 months.

■Frequently switching the product ON and OFF can lead to breakdown. Allow at least 3 minutes between subsequent operations of the product.

■Always fill the water tank and check the water level before operating. If the liquid level gauge goes below the "E" mark, an alarm will be generated and the product cannot be operated.

■The water pressure at the water supply port should be 0.50MPa or less. Too high pressure will result in the water supply failing to shut off or leakage.

■Always keep the water clean, inspect the water circuits monthly, and replace the water when necessary. Dirty water can damage mechanical seals and lead to leakage.

■Clean the condenser filter every month.

■Water cooled: The cooling water should be checked monthly to ensure that it is clean. The water should be changed if dirty.

RKS-J/J-M/G-MVW Series Important Unloading and Placement Information

WARNING = Failure to follow instructions contained in a WARNING may result in death or serious injury.

CAUTION = Failure to follow instructions contained in a CAUTION may result in injury to the operator or damage to property.

Pre-Unloading and Unloading Procedures

• Before Unloading After unpacking

Before Unloading After unpacking, confirm that the model number on the nameplate matches the model number of the item ordered. Abnormalities or other damage may occur during shipping or handling of the product. When receiving the product, check to make sure that there are no scratches or other abnormalities. If any damage or abnormality is detected, please contact the dealer where the product was purchased.

! WARNING

When using the optional suspension eyebolts, always use all 4 eyebolts and make sure there is at least a 60° angle between the top face of the product and each of the suspension cables. Improper suspension may lead to the product tipping over or falling, which could result in injury.

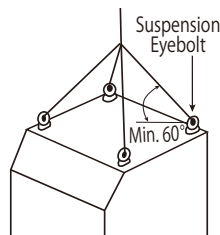

• Unloading Procedure

The product is heavy; please be careful when transporting it.

Model	Mass (Water tank empty)	
RKS401 • 402J-MV	-0 * *00	42 kg
RKS402J-MV	-1 * *00	46 kg
RKS401 • 402J-MV	-2 * *00	41 kg
RKS752J-MV	-0 * *00	45 kg
RKS752J-MV	-1 * *00	49 kg
RKS752J-MV	-2 * *00	44 kg
RKS753J-MV	-0 * *00	46 kg
RKS753J-V	-0 * *00	45 kg
RKS753J-MV	-1 * *00	50 kg
RKS753J-V	-1 * *00	49 kg
RKS753J-MV	-2 * *00	45 kg
RKS753J-V	-2 * *00	44 kg

Model	Mass (Water tank empty)	
RKS1502J-MV	-0 * *00	72 kg
RKS1502J-MV	-2 * *00	70 kg
RKS1503J-MV	-0 * *00	68 kg
RKS1503J-V	-0 * *00	67 kg
RKS1503J-MV	-2 * *00	66 kg
RKS1503J-V	-2 * *00	65 kg
RKS402J-MVW	-00000	44 kg
RKS402J-MVW	-20000	43 kg
RKS750G-MVW		55 kg
RKS1500G-MVW		85 kg

! WARNING

Installation of this product should be performed by your dealer or other qualified personnel. Improper installation by the end user may lead to water leakage, electric shock, fire or other problems.

Product Placement

• Choice of Installation Location

Choose an installation location that is free from combustible materials, areas that could lead to electric shock, or environments that could damage the product.

! CAUTION

Install on a level surface that can adequately support the weight of the product and fix the product down with anchor bolts or other means in order to prevent it from moving around. Failure to install as indicated can result in water leaks or injury etc., from the product tipping over or falling.

1. Ensure there is adequate space for heat ventilation as well as sufficient space for maintenance and inspection. If air cooled models are installed in an enclosed space as shown below, exhaust from the product can re-enter at the heat exchange air intake port which will cause the refrigerant high-pressure to increase and could cause the product to shut down.
2. If installing where a wind of 8 m/s or higher will be blown on it, measures to block the wind from hitting the product such as installation of a wind-break wall are required. (Air cooled models only.)

Overhead Obstacles (Roof, eaves, ceiling, etc.)

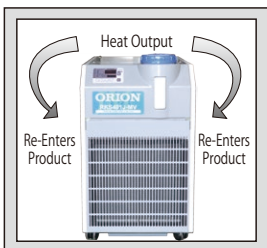

3. Install out of direct sunlight and do not install where the product would be affected by heat. Exposure to direct sunlight or heat can cause the product to perform below specified performance equal to the amount of that exposure. It can also lead to the activation of built-in protection devices which will prevent operation.

4. Please operate this product within the ambient temperature range as listed below:

Ambient Temp. Range (°C)	Model		
	RKS401 • 402 • 752 • 753 • 1502 • 1503J-MV • RKS402J-MVW	RKS753 • 1503J-V	RKS750 • 1500G-MVW
5 - 45	10 - 40	5 - 40	

5. Operating at temperatures below than 5 °C can damage the compressor. Operating at temperatures above 45 °C will result in reduced thermal performance of the condenser, reduced ability to cool the product, and could cause built-in safety devices to activate and product operation to stop.
6. If ducting is to be installed for air cooled models, have the installation performed by a qualified professional.

Fan Flow Rate (m³/min) 50/60Hz	Model	
	RKS401 • 402 • 752 • 753J-(M)V	RKS1502 • 1503J-(M)V
	24 / 28	48 / 56

7. Install in a place that is generally free of dust and dirt. Installation in places with heavy dust and dirt can result in reduction in performance.

[Ambient Temperature]

RKS401J-MV
RKS402J-MV
RKS752J-MV
RKS753J-MV
RKS1502J-MV
RKS1503J-MV
RKS402J-MVW

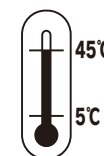

RKS753J-V
RKS1503J-V

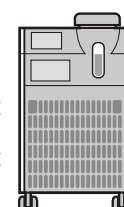
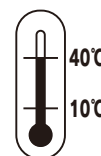

RKS750G-MVW
RKS1500G-MVW

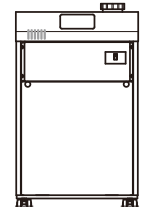
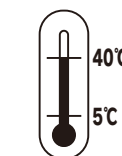

Water Supply and Drainage Construction

•Reliably install water supply and drainage piping. Improper water supply and drainage construction could result in water spraying out, causing water damage to the surrounding area.

•Ensure that the water supply pressure is 0.50 MPa or lower. (When an optional ball tap is installed.) Water leakage resulting from product damage can cause surrounding areas to become wet and may also cause electrical shocks.

Chilled Water / Cooling Water Piping

•Piping Sizes

Piping diameters for each model are listed below.

Model Piping Item		RKS-JM Series							RKS-J Series		RKS-GM Series (Water Cooled)	
		401J-MV	402J-MV	752J-MV	753J-MV	1502J-MV	1503J-MV	402J-MVW	753J-V	1503J-V	750G-MVW	1500G-MVW
Chilled Water Inlet	Piping Size	Rc1/2 39 N • m or less										
	Tightening Torque	Rc1/2 39 N • m or less										
Chilled Water Outlet	Piping Size	Rc1/2 39 N • m or less										
	Tightening Torque	Rc1/2 39 N • m or less										
Overflow Port	Piping Size	Rc 1/2 39N • m or less									—	
	Tightening Torque	Rc 1/2 39N • m or less									—	
Water Tank Drain	Piping Size	One Touch Joint (Cap)									Rp 1/2 29N • m or less	
	Tightening Torque	—										
Cooling Water Piping Inlet	Piping Size	—						Rc 1/2 39 N • m or less	—	Rc 1/2 39 N • m or less	Rc 3/4 59 N • m or less	
	Tightening Torque	—						Rc 1/2 39 N • m or less	—	Rc 1/2 39 N • m or less	Rc 3/4 59 N • m or less	
Cooling Water Piping Outlet	Piping Size	—						Rc 1/2 39 N • m or less	—	Rc 1/2 39 N • m or less	Rc 3/4 59 N • m or less	
	Tightening Torque	—						Rc 1/2 39 N • m or less	—	Rc 1/2 39 N • m or less	Rc 3/4 59 N • m or less	

•Piping Methods

Piping installation should follow the guidelines printed below.

1. Check the cooling water inlet and outlet side ports.
2. Make pipe lengths as short as possible, and also avoid vertical and curved piping as much as possible.
3. When tightening piping connections, use 2 pipe wrenches or adjustable wrenches in order to grasp both sides of the joint.
4. If required, a (user provided) bypass valve or drain valve should be installed on the cooling water inlet port in order to ensure the minimum water circulation flow rate.
5. Make sure that there is not excessive weight or vibration on the product from the connected piping. Longer lengths of horizontal piping should be supported with additional support hardware to ensure unreasonable forces are not applied directly to the product's connection ports. Failure to properly support piping can cause damage.
6. Piping should be insulated. (Allow for enough space between insulated pipes so that the lower right cabinet panel can be removed, and to allow operation of the bypass valve. Also make sure that the water pressure gauge will be visible after installation.)

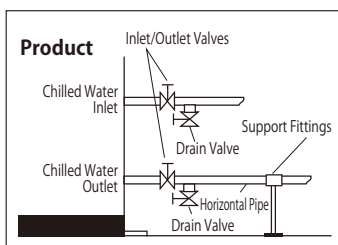
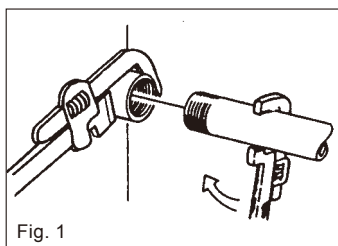

- If connections to the chilled water inlet and outlet ports are reversed, then no cooling will occur.
- When tightening piping, use 2 wrenches (pipe wrenches or adjustable wrenches, etc.) to support both sides of the connection and tighten to a torque according to the chart. (Fig. 1)
- Be careful during piping installation not to allow dirt, foreign material, sealing materials, etc., to enter the water circuit or water tank.
- It is recommended that piping be installed in order to avoid leakage from overflow.
- Always install valves (user supplied) at the cold water inlet and outlet ports.
- The drain valve is used to drain water from the piping when the product is not to be used for extended periods of time.
- If there is a chance that the cold water circuit could be blocked while the product is operating, then a safety valve (relief valve) should be installed to prevent water leakage and to maintain operation within the discharge pump operating range.
- Install a Y-strainer (user supplied) on the product inlet port. Also install a drain pan as required.
- Install a drain pan, as condensation may form on piping inside the product depending on the operating environment.
- Do not block the overflow piping. Blocked piping can result in water leakage within the product.
- Keep the discharge pump pressure within the specified operating range. If the pressure exceeds the upper limit, it could lead to freezing or damage to the evaporator, pump damage, or hoses coming off. If pressure goes below the lower limit, it could result in damage to the pump mechanical seals.
- Install the optional Bypass Valve Piping Kit (sold separately) if the pressure could exceed the prescribed upper limit, and operated the bypass valve to control the water pressure.

A Bypass Piping Kit is available as an optional accessory (sold separately) for RKS J, JM Series models.*
 * Model numbers ending with -2**00 indicate models that include bypass piping in the chiller.

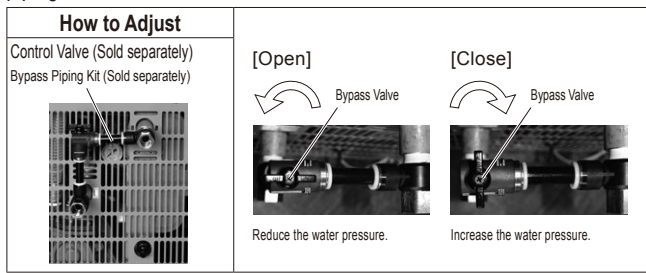

●Pipe Connection Procedure (Water cooled: RKS402J-MVW, RKS750 • 1500G-MVW)

1. Confirm the positions of the cooling water inlet and outlet ports.
 Install the cooling water inlet valve ① and cooling water outlet valve ②.
2. Be sure to mount the safety relief valve ③.
 The regulating valve that is installed in the cooling water circuit performs the opening and closing of the valve automatically by detecting the refrigerant pressure. Thus, there is a possibility that the

regulating valve becomes full-closed during operation. In order to prevent water leakage, maintain a water inlet pressure of 0.69 MPa or lower by installing a safety valve (relief valve) on the cooling water circuit.

3. Install the purge/drain valve ④.
4. Be sure to install the union coupling ⑤.

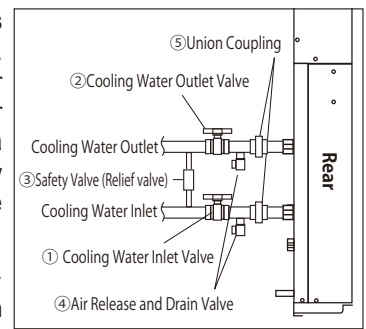

Make sure that it can easily disassemble the product and cooling water piping when carrying out the cleaning of water-cooled condenser in inside the product.

- If connections to the chilled water inlet and outlet ports are reversed, then no cooling will occur.
- When tightening piping, use 2 wrenches (pipe wrenches or adjustable wrenches, etc.) to support both sides of the connection and tighten to a torque according to the chart. (Fig. 1)
- Install the included Y-strainer before the cooling water inlet.

Electrical Work

- Ensure that all electrical wiring is done in accordance with relevant electrical construction regulations as well as the directions outlined in this manual. Furthermore, the product must be powered on its own electrical circuit. Installation with an insufficient power supply or improper installation can result in electric shock or fire.
- Be sure to connect the prescribed cables in a reliable manner, ensuring that there are no external forces exerted on cables or contact connectors. Improper cable connections may lead to electric shock, overheating of the contacts, or fire.
- Do not modify this product. Improper modifications to wiring or piping within the product can lead to electric shock or fire. Furthermore, modifying the product will void the product warranty.
- Never change the settings of built-in safety devices. Modifying such

settings can lead to an explosion or fire.

- Always properly ground this product. Do not attach the grounding wire to gas pipes, water pipes, lightning rods, etc. Improper grounding can lead to electric shock. (Installation of a Class-D ground hookup must be performed by a qualified electrician.)
 - An earth leakage breaker must be installed. Failure to install an earth leakage breaker can lead to electric shock.
 - Connect the product to a commercial power source. (Connection to the secondary side of the inverter will damage the product.)
 - Ensure the source voltage is within ±10 % of the specified voltage. Also make sure the source voltage phase unbalance* is within ±3 %.
- *Ensure the source voltage is within ±10 % of the specified voltage. Also make sure the source voltage phase unbalance* is within ±3 %.

$$*Phase\ unbalance\ (\%) = (Maximum\ voltage\ [V] - Minimum\ voltage\ [V]) \div Average\ voltage\ of\ 3\ phases\ (V) \times 67. \text{ (Based on IEC61800-3.)}$$

●Electrical Wiring [RKSJ, JM Series]

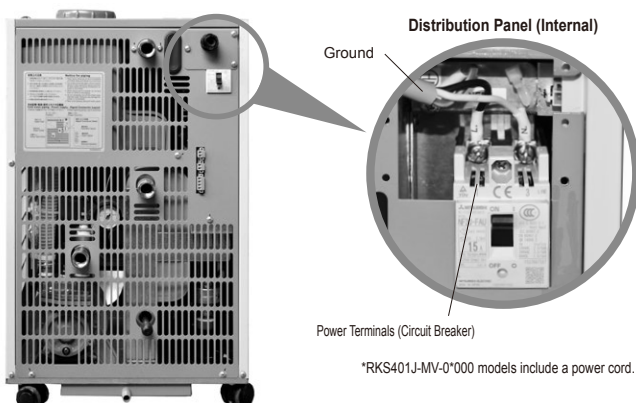

●Electrical Wiring [RKS750, 1500G-MVW]

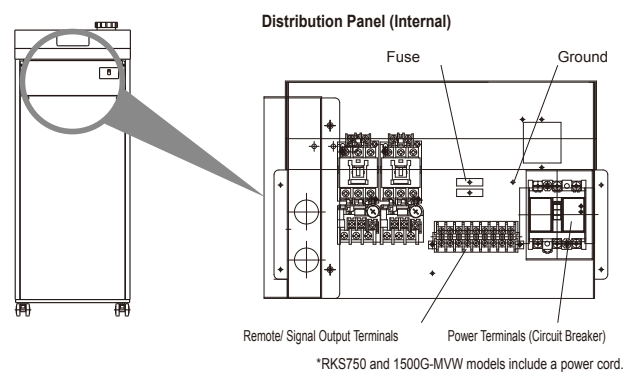

RKS Series Important Unloading and Placement Information

If the power cord is to be extended, refer to the chart below which shows the maximum operating current when choosing the cord. Always properly connect a ground wire to the product. (RKS401J-MV has a power cord which includes the grounding wire and therefore it should be not extended.)

Model	RKS-JM Series										RKS-J Series				RKS-GMVW Series			
	401J-MV	402J-MV	752J-MV	753J-MV	1502J-MV	1503J-MV	402J-MVW (Water cooled)	753J-V	1503J-V	750G-MVW	1500G-MVW							
Model Suffix	-0**00 -2**00	-0**00 -2**00	-1**00	-0**00 -2**00	-1**00	-0**00 -2**00	-1**00	-0**00 -2**00	-0**00 -2**00	-0**00 -2**00	-00000 -20000	-0**00 -2**00	-1**00	-0**00 -2**00				
Power Source (V • Hz)	Single-phase 100V ±10%		1φ200 - 230±10% • 50/60			3φ200±10% • 50/60, 220±10% • 60		1φ200 - 230 - 5%, +10% • 50/60		3φ200±10% • 50/60, 220±10% • 60		1φ200 - 230±10% • 50/60, 3φ200±10% • 50/60, 220±10% • 60						
Maximum Operating Current (A)	—	7.5	12.0	10	15.5	6	11.5	21	21.5	12	12.5	6.0	6.0	11.5	12	12.5	4.0	8.1

Wire the product independently with its own overload protection multi-purpose earth leakage breaker.

Model	RKS-JM Series										RKS-J Series				RKS-GMVW Series	
	401J-MV	402J-MV	752J-MV	753J-MV	1502J-MV	1503J-MV	402J-MVW (Water cooled)	753J-V	1503J-V	750G-MVW	1500G-MVW					
Model Suffix	-0**00 -2**00	-0**0 -2**0	-1**00	-0**00 -2**00	-1**00	-0**00 -2**00	-1**00	-0**00 -2**00	-0**00 -2**00	-00000 -20000	-0**00 -2**00	-1**00	-0**00 -2**00			
Circuit Breaker (A)	15	10	15	15	20	10	15	30	15	10	10	15	15	10	15	

The current setting of the discharge pump overcurrent relay (THR) needs to be changed depending on the operating conditions. (RKS1503J-V and RKS1500G-MVW Only)

Frequency	Discharge Pump Pressure Value	
	Less than 0.39 MPa	0.39 - 0.5MPa
50Hz	2.3 A (Default value)	2.3 A (Default value)
60Hz	2.3 A (Default value)	2.6 A (Changed value)

*When operating in areas with 60 Hz power, with a discharge pump pressure of 0.39 MPa or higher, the overcurrent relay (THR) current setting should be changed from 2.3 A to 2.6 A.

[IMPORTANT]

- Make sure the power cord does not come into contact with the motor or refrigerant piping within the product. Contact with hot surfaces could cause the cord to melt, resulting in an electrical short. (Secure power source wiring inside the distribution panel with cable ties.)
- Never allow the product to run dry. Always fill the water tank and confirm the water level before operating.
- Do not perform withstand voltage tests nor insulation resistance tests on this product. Doing so can damage the semiconductors used in the chiller control board or inverter. If the tests are deemed necessary, please consult your dealer.

If Employing Remote Control Operation

If remote operation and signal outputs are to be utilized, please confirm wiring specifications before performing wiring construction. Remove the terminal block on the rear of the product and connect 0.75 mm² or smaller diameter wires.

Carefully check the following specifications.

Remote Operation Input Specifications	• No-voltage contacts input	
	• Max. wiring length:	Max. 20 m
Signal Output Specifications	• Input power resistance	1200 Ω
	• Open circuit voltage (Voc)	12 VDC
Remote Operation Input Specifications	• Short circuit current (Isc)	10 mA
	• Voltage Input Specifications	
Signal Output Specifications	• Rated voltage	12 VDC - 24 VDC
	• Input power resistance	1200 Ω
Remote Operation Input Specifications	• Relay output	"a" type contact
	• AC250 V / DC30 V	3 A (Resistive load)
Signal Output Specifications	• Minimum operating current (For reference only)	5 VDC 100 mA

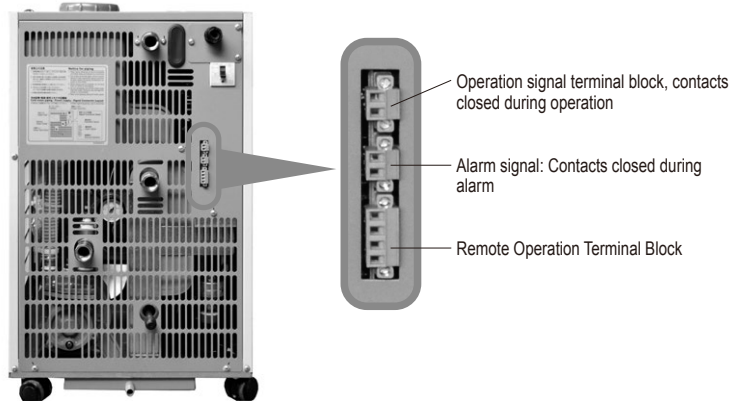

•RKS J/ JM Series

Remote Operation Terminal Block	No-Voltage Contacts Input Specifications	Voltage Contacts Input Specifications
	Short terminals 1 and 3. Connect input wires to contact terminals 2 and 4. 	Apply voltage input between terminals 3 and 4.

•RKS750, 1500G-MVW

Remote Operation Terminal Block	Remote Operation																
Signal Output Contacts	<table border="0"> <tr> <td>Operation Signal</td> <td> <table border="0"> <tr> <td>24] When Power is Cut Off</td> <td>: 24-26 Closed, 25-26 Open</td> </tr> <tr> <td>25] When Equipment is Stopped</td> <td>: 24-26 Closed, 25-26 Open</td> </tr> <tr> <td>26] When Equipment is Operating</td> <td>: 24-26 Open, 25-26 Closed</td> </tr> </table> </td> </tr> <tr> <td>Alarm Signal</td> <td> <table border="0"> <tr> <td>27] When Power is Cut Off</td> <td>: 27-29 Closed, 28-29 Open</td> </tr> <tr> <td>28] Warning Disabled</td> <td>: 27-29 Closed, 28-29 Open (Default)</td> </tr> <tr> <td>29] During Alarm Condition</td> <td>: 27-29 Open, 28-29 Closed (Default)</td> </tr> </table> </td> </tr> </table>	Operation Signal	<table border="0"> <tr> <td>24] When Power is Cut Off</td> <td>: 24-26 Closed, 25-26 Open</td> </tr> <tr> <td>25] When Equipment is Stopped</td> <td>: 24-26 Closed, 25-26 Open</td> </tr> <tr> <td>26] When Equipment is Operating</td> <td>: 24-26 Open, 25-26 Closed</td> </tr> </table>	24] When Power is Cut Off	: 24-26 Closed, 25-26 Open	25] When Equipment is Stopped	: 24-26 Closed, 25-26 Open	26] When Equipment is Operating	: 24-26 Open, 25-26 Closed	Alarm Signal	<table border="0"> <tr> <td>27] When Power is Cut Off</td> <td>: 27-29 Closed, 28-29 Open</td> </tr> <tr> <td>28] Warning Disabled</td> <td>: 27-29 Closed, 28-29 Open (Default)</td> </tr> <tr> <td>29] During Alarm Condition</td> <td>: 27-29 Open, 28-29 Closed (Default)</td> </tr> </table>	27] When Power is Cut Off	: 27-29 Closed, 28-29 Open	28] Warning Disabled	: 27-29 Closed, 28-29 Open (Default)	29] During Alarm Condition	: 27-29 Open, 28-29 Closed (Default)
Operation Signal	<table border="0"> <tr> <td>24] When Power is Cut Off</td> <td>: 24-26 Closed, 25-26 Open</td> </tr> <tr> <td>25] When Equipment is Stopped</td> <td>: 24-26 Closed, 25-26 Open</td> </tr> <tr> <td>26] When Equipment is Operating</td> <td>: 24-26 Open, 25-26 Closed</td> </tr> </table>	24] When Power is Cut Off	: 24-26 Closed, 25-26 Open	25] When Equipment is Stopped	: 24-26 Closed, 25-26 Open	26] When Equipment is Operating	: 24-26 Open, 25-26 Closed										
24] When Power is Cut Off	: 24-26 Closed, 25-26 Open																
25] When Equipment is Stopped	: 24-26 Closed, 25-26 Open																
26] When Equipment is Operating	: 24-26 Open, 25-26 Closed																
Alarm Signal	<table border="0"> <tr> <td>27] When Power is Cut Off</td> <td>: 27-29 Closed, 28-29 Open</td> </tr> <tr> <td>28] Warning Disabled</td> <td>: 27-29 Closed, 28-29 Open (Default)</td> </tr> <tr> <td>29] During Alarm Condition</td> <td>: 27-29 Open, 28-29 Closed (Default)</td> </tr> </table>	27] When Power is Cut Off	: 27-29 Closed, 28-29 Open	28] Warning Disabled	: 27-29 Closed, 28-29 Open (Default)	29] During Alarm Condition	: 27-29 Open, 28-29 Closed (Default)										
27] When Power is Cut Off	: 27-29 Closed, 28-29 Open																
28] Warning Disabled	: 27-29 Closed, 28-29 Open (Default)																
29] During Alarm Condition	: 27-29 Open, 28-29 Closed (Default)																

• Perform remote operation and signal output wiring so that no undue strain is placed on connection terminal block.

•When Using Communications Functions

RS-422A (RS-485)	<ul style="list-style-type: none"> • Attach the stripped wires and use as is. • Data cable wire size: AWG16 - 24 • Data cable max. length: Max. 100 m (from host to terminal end) *May differ depending on specific operating conditions.
------------------	---

RKE and RKS Series Common Data

Cooling Water

●Choosing Cooling Water

Basically, cooling water for the water cooled condenser can be underground water, tap water, or water from a cooling tower. However, the final choice should be made after carefully considering the following points.

●Water Quality Standard Guidelines

Primary cooling water (refrigeration unit condenser cooling water, constant temperature water for the water temperature controller, and humidification water) should meet the water quality standard as described in the chart on the right.

1. Primary Cooling Water Quality Standards

- (1) If tap water is used as the primary cooling water for water cooled equipment, then the water should meet the following water quality standard.
- (2) Within the "Tendency toward" column, items marked with a \circ indicate this component can lead to corrosion or scaling as indicated.
- (3) The 15 items listed to the right are the primary components that can lead to corrosion or scaling.

●Using Tap Water

Note that the constant release of tap water (where the cooling water outlet circuit is in an open loop system) can result in dezincification corrosion and breakdown of the water regulating valve.

* Use for make-up water when operating with a cooling tower.

Clause	Cooling Water		Tendencies		
	Circulation water	Supplied water	Corrosion	Scaling	
Standard Items	pH (25 °C)	6.5 to 8.2	6.0 to 8.0	\circ	\circ
	Electric conductivity ($\mu\text{S}/\text{cm}$) (25 °C)	800 or below	300 or below	\circ	\circ
	Chloride ion (mgCl^-/L)	200 or below	50 or below	\circ	
	Sulfate ion ($\text{mgSO}_4^{2-}/\text{L}$)	200 or below	50 or below	\circ	
	Acid consumption (pH4.8) (mgCaCO_3/L)	100 or below	50 or below		\circ
	Total hardness (mgCaCO_3/L)	200 or below	70 or below		\circ
	Calcium hardness (mgCaCO_3/L)	150 or below	50 or below		\circ
	Ionic Silica (mgSiO_2/L)	50 or below	30 or below		\circ
Reference Items	Iron (mgFe/L)	1.0 or below	0.3 or below	\circ	\circ
	Cu (mgCu/L)	0.3 or below	0.1 or below	\circ	
	Sulfide ion (mgS^{2-}/L)	None detected	None detected	\circ	
	Ammonium ion (mgNH_4^+/L)	1.0 or below	0.1 or below	\circ	
	Residual chlorine (mgCl/L)	0.3 or below	0.3 or below	\circ	
	Free carbon dioxide (mgCO_2/L)	4.0 or below	4.0 or below	\circ	
	Stability index	6.0 to 7.0	-	\circ	\circ

* Excerpt from JRA-GL-02-1994 guidelines from The Japan Refrigeration and Air Conditioning Industry Association.

Chilled Water

●Chilled Water Standards

Liquid (chilled water) that can be used are either clean water and a 30 to 40 % ethylene glycol solution. Alternatively, if deionized water is to be used, it should have an electrical conductivity of at least 1 $\mu\text{S}/\text{cm}$. Cooling

non-approved liquids can result in equipment damage, leaking, and possible electric shock or electrical shorts.

	Item	Standard levels
Standard components	pH(25 °C)	6.8 - 8.0
	Conductivity ($\mu\text{S}/\text{cm}$) (25 °C)	1 - 400
	Chloride ion (mgCl^-/L)	Max. 50
	Sulphate ($\text{mgSO}_4^{2-}/\text{L}$)	Max. 50
	Acid consumption (pH4.8) (mgCaCO_3/L)	Max. 50
	Total hardness (mgCaCO_3/L)	Max. 70
	Calcium hardness (mgCaCO_3/L)	Max. 50
	Silica ion (mgSiO_2/L)	Max. 30

	Item	Standard levels
Reference components	Iron (mgFe/L)	Max. 1.0
	Copper (mgCu/L)	Max. 1.0
	Sulfide ion (mgS^{2-}/L)	Not detected
	Ammonium ion (mgNH_4^+/L)	Max. 1.0
	Residual chlorine (mgCl/L)	Max 0.3
	Free carbon dioxide (mgCO_2/L)	Max. 4.0

* Excerpt from JRA-GL-02-1994 guidelines from The Japan Refrigeration and Air Conditioning Industry Association.



Orion Products -- Service and Safety

● Safety Notes

- Before operating this equipment, please read the operating manual carefully, and only use as indicated.
- For installation of this equipment and required wiring, employ a qualified person or consult with your dealer.
- Be sure to select equipment which suits your needs. Do not use this equipment for purposes other than those for which it is intended. Doing so can lead to accidents or equipment breakdown.

● Air-Cooled Models

If the condenser becomes clogged with dust or dirt, heat exchange will be greatly reduced and electricity consumption will increase. This will lead not only to decreased performance, but can also lead to the activation of built-in safety devices, and eventual damage to the equipment. For these reasons, the condenser should be cleaned on a regular basis.

● Water-Cooled Models

In general, water used to cool condensers will be well-water, tap water, or water from a cooling tower. However water of insufficient quality can lead to scaling in cooling pipes resulting in lower levels of heat exchange, increased electricity consumption and lower performance. Therefore water quality should be confirmed on a regular basis.

Regarding After-Service

- For information regarding repair of equipment that has been in operation, please consult your dealer.
- The customer will be responsible for charges incurred for repairs conducted after the warranty period has expired. In cases where equipment function can be improved by certain service procedures, such procedures will be taken at the specific request of the customer.
- Regarding spare parts... "Spare parts" are those which are necessary in order to maintain the function of the product. It is the policy of ORION to maintain a stock of replacement parts for 7 years after production of the product ceases.

Recommended Maintenance Inspections

- Depending on the particular item, extended use can lead to the product becoming dirty or worn, which can lead to decreased performance. In order to realize continued best performance of this equipment, in addition to prescribed customer maintenance, it is also recommended that regular inspections be conducted. (Service and inspection fees apply.) For further information please consult your dealer or contact ORION directly.

Refrigerant Management

Some of the products in this catalog contain HFC refrigerants. Refrigeration technologies that use HFC refrigerants are essential for achieving efficient temperature control, and while such technologies make great contributions toward saving energy, there is also concern of the impact that the accidental release of HFC refrigerants into the atmosphere has on global warming.

When dealing with HFCs, please ensure compliance with laws and regulations and be sure to manage them appropriately for your safety and for the protection of the environment.

●GWP Values of Refrigerants Used in Our Products

Refrigerant	Global Warming Potential
	(100-year GWP)
R134a	1430
R404A	3920
R407C	1770
R410A	2090
R32	675

* For details about the refrigerant used in specific products, please refer to the product's specification page.

ORION is continuing to develop a complete and trustworthy nationwide network of expedient sales and service -- everywhere, anytime.



*ORION has wide reaching regional service bases in various countries throughout the world. Please consult your ORION dealer for details.



ISO 9001, 14001

ORION Machinery Co., Ltd is an ISO Certified, Quality Management and Environmental Management company.

— What is the ISO certification system?

ISO (International Organization for Standardization) is an established body that stipulates and certifies ISO9001 and ISO14001 directives. ISO9001 stipulates a system of Quality Management that ensures customer satisfaction and trust in a company's products and services it provides. ISO14001 stipulates a system of Environmental Management whereby production and business activities are carried out in an environmentally conscious manner.

For inquiries, please contact the following representative:

Distributed by:

KOBELCO

PT KOBELINDO COMPRESSORS



+62 811 8754 185

www.kobelindo.co.id

ORION MACHINERY CO.,LTD.

International Group 246, Kotaka, Suzaka-shi, Nagano-ken, 382-8502 Japan
TEL +81-(0)26-246-5664 FAX +81-(0)26-246-5022
Email: kokusai@orionkikai.co.jp

Head Office & Factory 246, Kotaka, Suzaka-shi, Nagano-ken, 382-8502 Japan
TEL +81-(0)26-245-1230 FAX +81-(0)26-245-5424
URL: <http://www.orionkikai.co.jp>