

Heavy Duty Chiller with Built-in Water Tank

ORION Inverter Chillers Contribute To High Productivity With Reliable Quality!



Energy Saving Proposal

Global Service Network

Product Lineup

Application Examples

RKE-C Series

RKE-B Series

CE Marking Certified Chillers RKE-B Series

Brine Chiller RKE-B Series

RKE-A Series

Accessories

Important Unloading and Placement Information

Information

Energy savings and high precision control

Energy Saving Proposal

Example

Change-up from Inverter-less Chiller to RKE3750C-V

Energy Savings

69%
Reduction

Difference in Power Consumption

12,000
kWh

Reduction in CO₂ Output

5,400
kg CO₂/year

Comparison Conditions

Compared Models :

Inverter-less Chiller
RKE3750C-V

Water Temp. Setting :
20°C

Ambient Temperature :
32°C

Average Load :
4.9kW (40% of Rated Load)

Operating Time :
10 hours/day (250 days/year)

Electricity Cost :
Please calculate to see how much you can save.

Power Consumption Rate Based on Chiller Load Factor

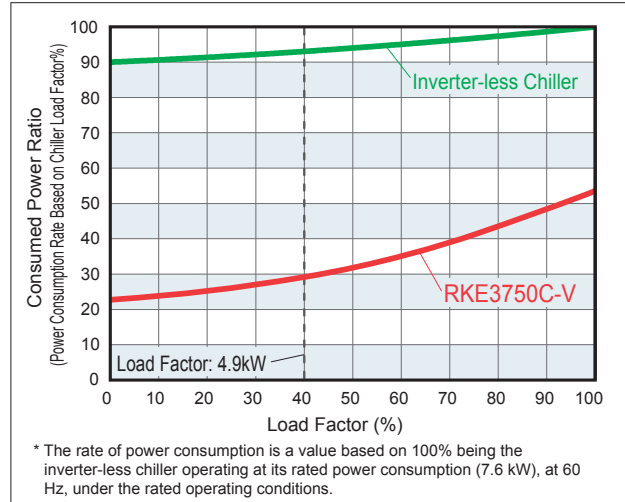

Reduction in CO₂ Output

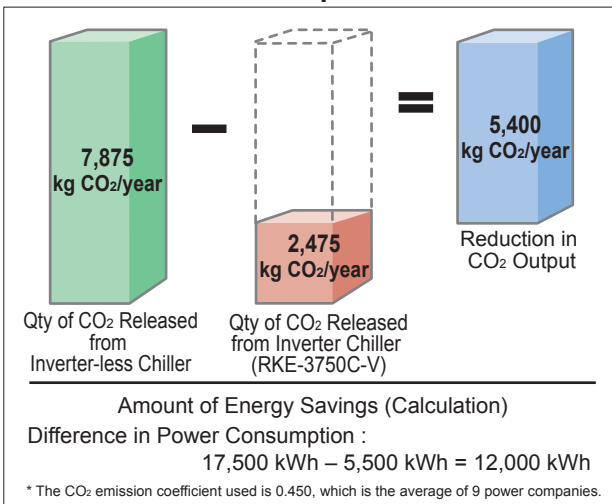

Yearly Power Consumption Comparison

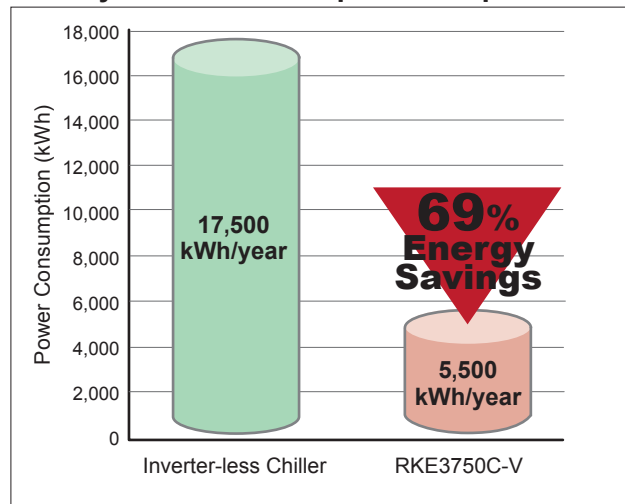

Global Service Network

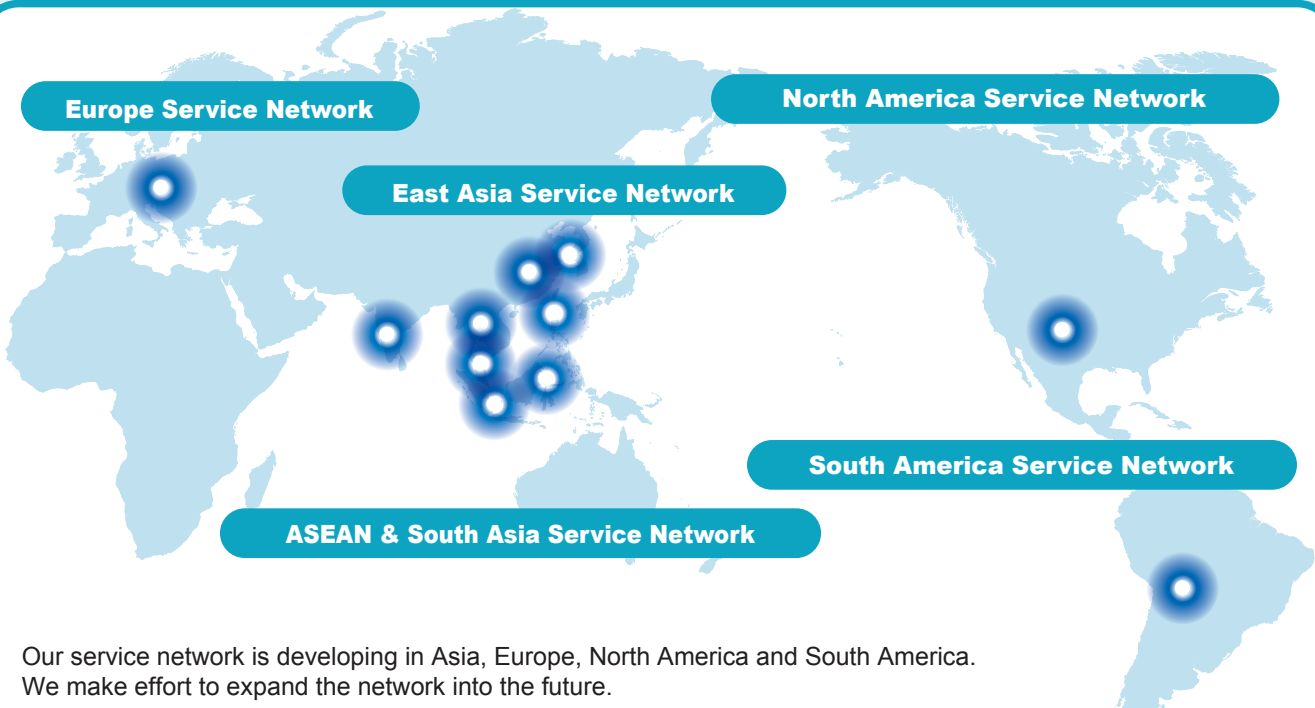

Our service network is developing in Asia, Europe, North America and South America. We make effort to expand the network into the future.

East Asia Service Network

- ORION Machinery (Shanghai) Co., Ltd. (China)
- Dongguan Orion Machinery Co., Ltd. (China)
- ORION (HONG KONG) Co., Ltd. (Hong Kong)
- ORION KOREA Co., Ltd. (South Korea)
- Taiwan Orion Industry Co., Ltd. (Taiwan)

ASEAN Service Training Center

- ORION Machinery Asia Co., Ltd. (Thailand)

Europe Service Network

Europe Customer Support Center

- Limko N.V. (Belgium)
- Italy U.K. Germany France
- Sweden Norway Hungary Czech

ASEAN & South Asia Service Network

- Siam Seimitsu (Thailand)
- iwatech Malaysia (Malaysia)
- iwatech Singapore (Singapore)
- VE & JA (Vietnam)
- Tan Dai Phu Sy (Vietnam)
- MESCO (Philippines)
- PT. S-Tech (Indonesia)
- GEM Orion Machinery (P) Ltd. (India)

North America Service Network

North America Customer Support Center

- ORION Machinery North America (US)
- Over 150 locations throughout US, Canada and Mexico.

South America Service Network

- A&M Engenharia (Brazil)

Products



Air Dryer



Chiller



Precision Air Processor

Product Lineup

Classification		Model *1	Refrigerant	Cooling Capacity *2 (50/60Hz)
NEW RKE-C Series	Air Cooled 	RKE3750C-V-G1/G2	R32	12.2 kW
		RKE4500C-V-G1/G2		16.0 kW
		RKE5500C-V		20.5 kW
		RKE7500C-V		25.0 kW
		RKE9000C-V		30.0 kW
	Water Cooled 	RKE3750C-VW-G1/G2	R32	16.0 kW
RKE5500C-VW	24.0 kW			
RKE7500C-VW	30.0 kW			
RKE-B Series	Air Cooled 	RKE11000B1-V	R410A	37.2 kW
		RKE15000B-V		48.0 kW
		RKE22000B-V		74.4 kW
		RKE30000B-V		96.0 kW
	Air Cooled CE Marking 	RKE3750B-V-CE-G1/G2		12.2 kW
		RKE5500B-V-CE		20.3 kW
		RKE7500B-V-CE		25.0 kW
		RKE11000B-V-CE		37.2 kW
		RKE15000B-V-CE		48.0 kW
	Air Cooled Brine 	RKE3750B-VL-G1/G2		3.6 kW
		RKE5500B-VL		8.3 kW
	Water Cooled 	RKE11000B1-VW		R410A
RKE15000B-VW		48.0 kW		
Water Cooled CE Marking 		RKE3750B-VW-CE-G1/G2	14.1 kW	
		RKE5500B-VW-CE	23.4 kW	
		RKE7500B-VW-CE	27.3 kW	
		RKE11000B-VW-CE	43.0 kW	
		RKE15000B-VW-CE	48.0 kW	
RKE-A Series		Air Cooled 	RKE18000A-V	
	RKE22000A-V		70.0 kW/73.0 kW	
	Water Cooled 	RKE18000A-VW	R407C	57.0 kW/60.0 kW
		RKE30000A-VW		96.0 kW

Operable Liquid Temperature Range	Control Precision *3	Operable Ambient Temperature Range	Listing Page
5 to 35 °C (w/ brine: 0 to 35 °C)	±0.1 °C (Energy saving mode: ±2.0 °C)	-20 to 50 °C *4	P.7
5 to 35 °C (w/ brine: 0 to 35 °C)	±0.1 °C (Energy saving mode: ±2.0 °C)	2 to 45 °C	P.7
5 to 35 °C (w/ brine: 0 to 35 °C)	±0.1 °C (Energy saving mode: ±2.0 °C)	-20 to 45 °C	P.37
			P.61
-5 to 10 °C			P.65
5 to 35 °C (w/ brine: 0 to 35 °C)	±0.1 °C (Energy saving mode: ±2.0 °C)	2 to 45 °C	P.41
			P.63
5 to 35 °C	High Precision Mode: ±1.0 (±0.5 when the load is stable) Energy Saving Mode: ±1.0 (±0.5 when the load is stable / ±2.0 when the compressor is switching on and off.)	-5 to 43 °C	P.67
5 to 35 °C	High Precision Mode: ±1.0 (±0.5 when the load is stable) Energy Saving Mode: ±1.0 (±0.5 when the load is stable / ±2.0 when the compressor is switching on and off.)	2 to 43 °C	P.67
15 to 30 °C			P.69

*1 G1: Without casters, G2: With casters

*2 <Air-cooled Models> Operating conditions: Chilled water temp.: 20 °C, Ambient temp.: 32 °C. <Water-cooled Models> Operating conditions: Chilled water temp.: 20 °C, Cooling water temp.: 32 °C, Ambient temp.: 32 °C. <RKE-B-VL Series> Operating conditions: Chilled water temp.: -5 °C, Ambient temp.: 32 °C. Cooling capacity is at least 95% of listed figures.

*3 Continuous current load fluctuation within ±10%, and with stable ambient temp. and power supply, etc.

*4 -20 to 45 °C when the setting temperature is below 5 °C.

Application Examples

Washing and Cleaning Machines

Used for hydrocarbon and solvent regeneration and recovery.



Injection Molding Machines

Post-molding die cooling (to promote post-molding resin curing).

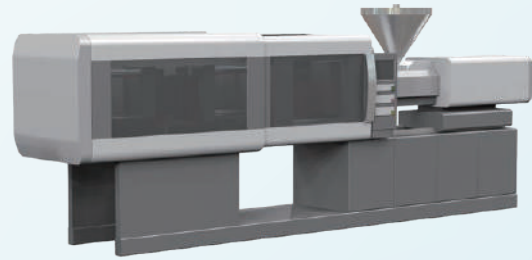

Water-cooled Air Compressors

Supply of cooling water to water-cooled air compressors



High Frequency Induction Heating

Cooling of heating coil and high frequency power supply



Laser Machines

Cooling of oscillator and optical systems of fiber/CO₂/YAG lasers.

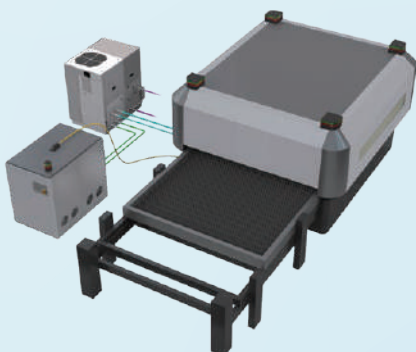

Milling Equipment

Supply of cooling water to cooling jacket



Packaging Machines

Cooling after heat sealing

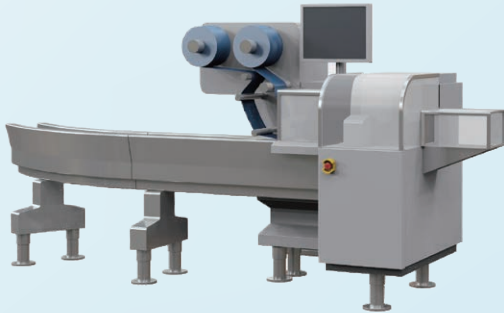

Mixers

Supply of cooling water to cooling jacket



Direct Image Printing Equipment

UV lamp cooling and ink drying, cooling stage cooling, and ink temperature control

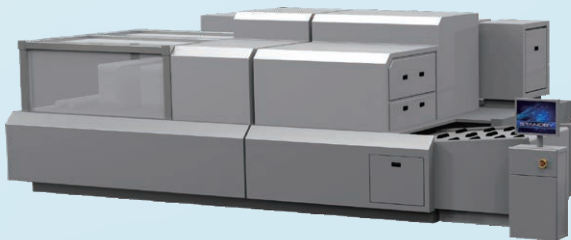

Vacuum Vapor Deposition Equipment

Chamber cooling



A stable supply of chilled water using Orion Water Chillers may also help in the following cases.

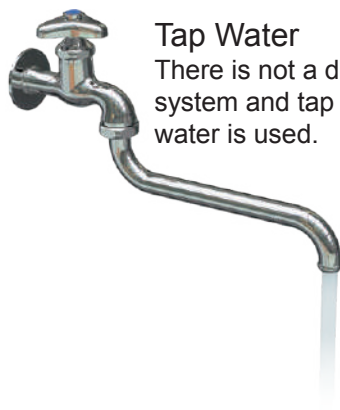

Tap Water
There is not a dedicated cooling system and tap water or other running water is used.



Cooling Tower
The cooling water temperature is not stable, and the equipment is not performing well.

RKE-C Series

Air Cooled Water Cooled

Models	RKE3750C-V(W)
	RKE4500C-V
	RKE5500C-V(W)
	RKE7500C-V(W)
	RKE9000C-V

IPX4 Equiv. Rating: Splash-proof Bypass Valve Included as Standard Equipment

Low GWP R32	Air Cooled	Water Cooled	Inverter (TESC)	High Ambient Temp. (Air-cooled Models)
Intelligent Touch Panel	Low Noise Operation	Reduced Footprint (Water-cooled Models)	IoT* (*See page 73.)	IPX4 Equiv. Rating: Splash-proof

Cooling Capacity	12.2 to 30.0 kW	Operable Liquid Temperature Range	5 to 35 °C
Operable Ambient Temperature Range	-20 to 50 °C*(Air Cooled) 2 to 45 °C(Water Cooled)	Refrigerant	R32

* -20 to 45 °C when the temperature setting is below 5 °C.

Carefree 2-year Warranty
* Warranty period of the refrigerant circuits 2 years from the date of purchase (or 10,000 hours of operating time).



RKE-C Series

Built-in TESC realizes high precision control with minimal power consumption.

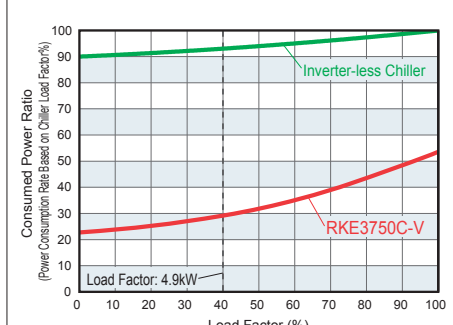
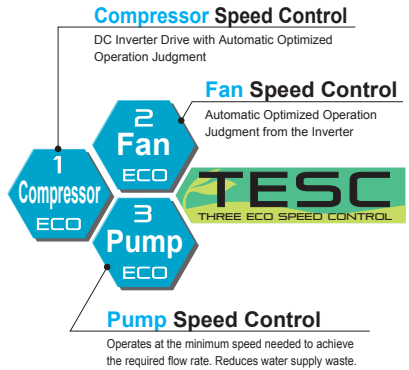

* The rate of power consumption is a value based on 100% being the inverter-less chiller operating at its rated power consumption (7.6 kW), at 60 Hz, under the rated operating conditions.

Power consumption changes with the load factor. The RKE-C Series exhibits lower power consumption over conventional models thanks to TESC.

Selectable Pump Control Method
Can set operating frequency, flow rate*, or water pressure.

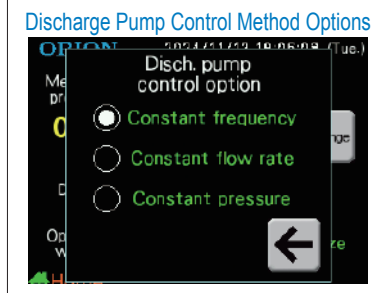

* The displayed flow rate is a calculated value. The actual flow rate may differ.

Intelligent Touch Panel

Various settings and operating conditions can be visually and intuitively checked and operated via the touch panel controller.

Alarm numbers are displayed when alarm conditions occur. Touching "Details" will show details about the alarm and suggestions on how to deal with it.

MODBUS Protocol Standard Built In

The displayed language can be changed to English, Japanese or Chinese.

Japanese language mode

Chinese language mode

Low Noise Design

Ideal inverter fan speed control through optimized refrigeration cycle control. Achieves much lower operating noise levels.

* Operating noise measured from a distance of 1 m from the front of the product at a height of 1 m.



RKE3750C-V/VW 58dB(58dB) / 62dB(56dB)

RKE4500C-V 60dB(57dB)

RKE5500C-V/VW 62dB(59dB) / 60dB(57dB)

RKE7500C-V/VW 62dB(59dB) / 62dB(58dB)

RKE9000C-V 65dB(62dB)

* Values in () are when the optional Noise Reduction Kit is installed (sold separately).

Increased Operating Ambient Temperature Range (Air-cooled models only)

The operable ambient temperature range has been increased to 50 °C on standard models. (Air-cooled models only.) Use with confidence even as outside air temperatures rise year by year due to global warming.

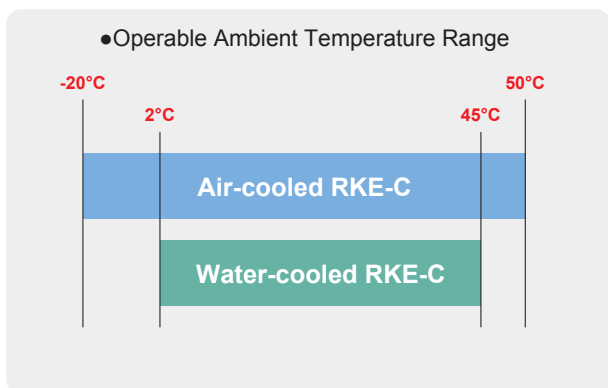

Energy Saving Mode Built In on Standard Models

Increased reductions in power consumption are possible when the power saving mode is selected.

* Under the energy saving mode, compressor operation is stopped to save energy when the cooling load is low. Note that the liquid temperature will fluctuate approx. ± 2.0 °C from the set temperature during the process of starting and stopping the compressor.

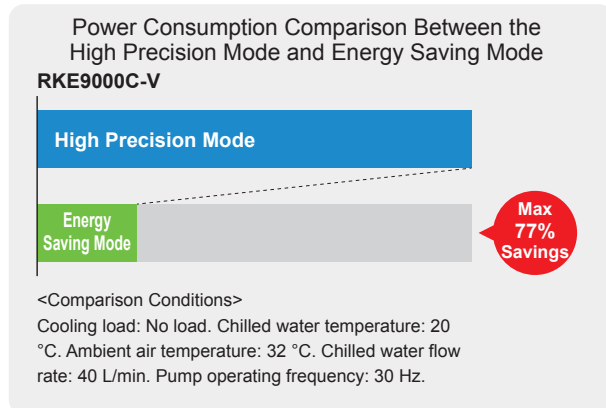

RKE-C Series

Air-cooled Model Features

Achieves Highly Efficient Operation

By placing condensers on the top and on 3 sides, variations in air intake volume are reduced and operating efficiency is greatly improved.

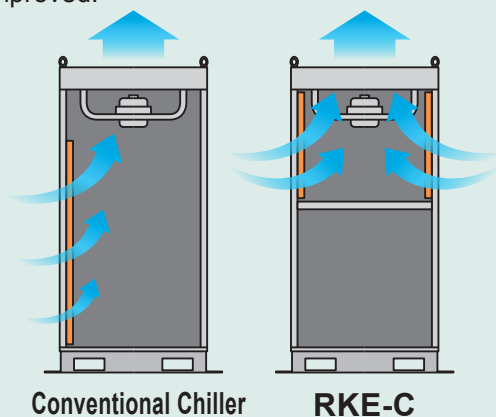

Water-cooled Model Features

Space-saving Installation is Possible

The installation footprint is reduced by 42% compared with conventional models.



Specifications

Model		RKE3750C-V G1 / G2 (With casters)	RKE4500C-V G1 / G2 (With casters)	RKE5500C-V	RKE7500C-V	RKE9000C-V				
Performance Specifications	Cooling Capacity *1	kW		12.2	16.0	20.5	25.0	30.0		
	Legal Refrigeration Tonnage			1.25	1.59	2.16	2.61	3.05		
	Heating Capacity *9	kW		2.5	3.0	3.5	4.5	4.5		
	Operable Ambient Temperature Range *8	°C		-20 to 50 *11						
	Operable Liquid Temperature Range	°C		5 to 35 (w/ brine: 0 to 35 *6 *11)						
	Control Precision *4	°C		±0.1 °C *5 (Energy saving mode: ±2.0 °C)						
	Maximum Operating Pressure	MPa		0.5						
Pressure Setting Range	MPa		0.08 to 0.5							
Operating Flow Rate	L/min		25 to 70		40 to 170					
Power Specifications	Power Source *2	V(Hz)		Three-phase 200 to 220 ±10% (50/60)						
	Power Consumption *1	kW		4.1	5.7	7.0	8.0	9.9		
	Electric Current *1	A		13.1	17.9	21.9	24.7	30.6		
	Power Capacity *3	kVA		5.2	7.1	9.3	11.0	13.0		
Operation Control Method			Compressor speed control							
Equipment Details	Compressor	Construction		Fully sealed rotary type						
		Output	kW		1.85 (Inverter driven)		3.8 (Inverter driven)			
	Condenser		Fin and tube forced-air cooling							
	Heat Exchanger	Construction		Plate type heat exchanger						
		Material		SUS316 (Brazing: Cu)						
	Discharge Pump	Construction		Multistage centrifugal immersion type						
		Output	kW		1.1 (Inverter driven)		1.5 (Inverter driven)			
	Fan Motor	Output	kW		0.4 (Inverter driven)		0.75 (Inverter driven)			
	Water Tank Capacity *7	L		Approx. 40		Approx. 60				
	Refrigerant		R32							
Charged Amount	kg		2.0		2.9		3.3			
External Dimensions (H×D×W)	mm		G1 : 1500×770×720 G2 : 1606×770×720		1630×900×880		1800×900×880			
Unit Mass (dry weight)	kg		G1 : 207 G2 : 211		282		296			
Operating Noise Level *10	dB		58		60		62		65	

*1 Operating conditions: Chilled water temp.: 20 °C, Ambient temp.: 32 °C. Cooling capacity is at least -5% of listed figures. *2 Source voltage phase unbalance should be less than ±3%. *3 The figure noted is when operating at the highest capacity in the normal operating range. *4 The setting can be changed by changing parameter F015. *5 When the continuous current load fluctuation is within ±10%, and the ambient temperature and power supply, etc. are stable. Does not apply in the following cases: (1) After the compressor starts until the chilled water temperature is stable. (Temperature control will start approx. 1 minute after the compressor starts.) (2) When the refrigeration load is so small such that the compressor is cycling on and off, or the heating-side electronic expansion valve is switching between fully closed to open, or from open to fully closed. When the liquid injection solenoid valve opens or closes. (3) When the current load varies more than ±10%. (4) When the water temperature setting is changed. *6 Brine means a 30 to 50% industrial-use ethylene glycol solution, or 30 to 70% industrial-use propylene glycol solution. *7 When the liquid level gauge is at "F". *8 Not frozen. *9 Only during startup. The ambient temperature is 32 °C. Will change depending on the ambient temperature. (Factory default setting: Heating operation: Off) *10 Operating noise levels are from a position of 1 m in front of the product and at a height of 1 m. *11 Operable ambient temperature range will be -20 to 45 °C when the set temperature is below 5 °C (brine must be used).

Note 1: The liquid (chilled water) that can be used with this product is either clean water, a 30% to 50% industrial-use ethylene glycol solution, or a 30 to 70% industrial-use propylene glycol solution. However, also be aware that using one of these solutions can result in a 10% drop in cooling capacity. Also, if using deionized water, ensure that the electrical conductivity is 1 µS/cm or higher.

Note 2: Heat output from the product (in kW) is approx. 1.3 times that of the cooling capacity.

Note 3: This product contains a refrigerant gas that is slightly flammable. In order to prevent fires in the event of refrigerant gas leakage when the product is installed indoors, provide adequate ventilation and do not allow flames nearby.

Flow Rate Characteristics Diagram

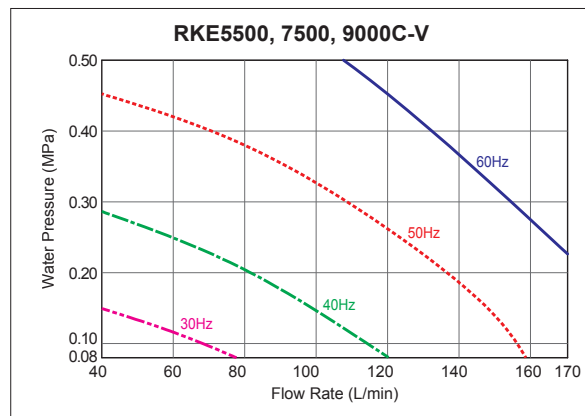
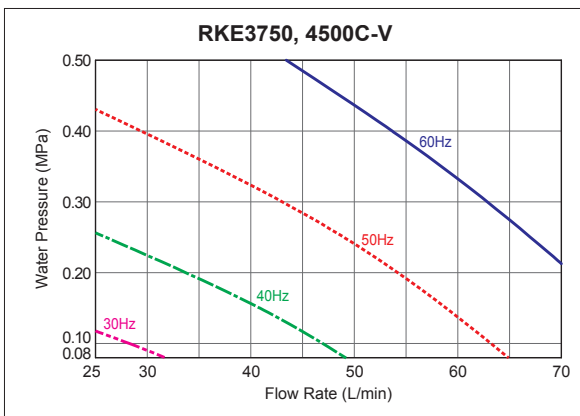

* The illustration shows the actual measured flow rate value when the bypass valve is closed.

* Flow rate changes based on inverter frequency.

* If additives are used, the flow rate characteristics will change due to factors such as the additive used, the concentration, fluid temp, etc.

* Install valves on the chilled water inlet and outlet ports so that the flow rate and pressure can be adjusted.

Cooling Capacity

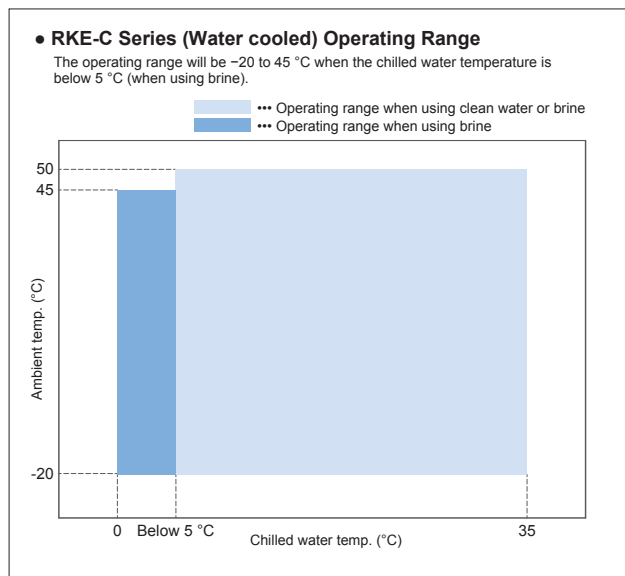
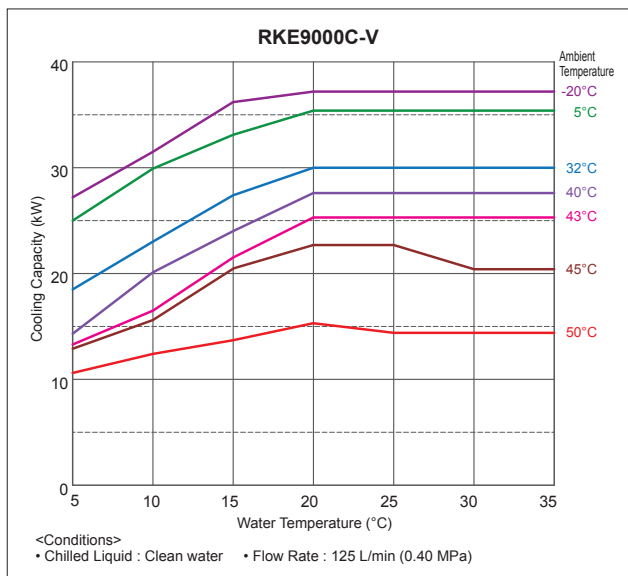
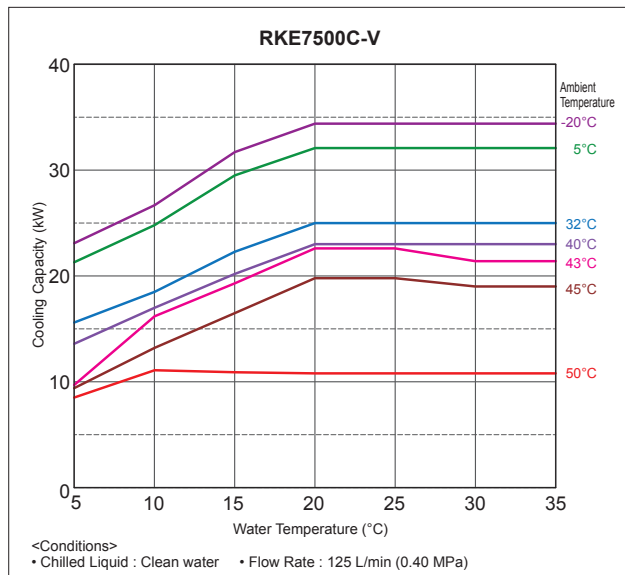
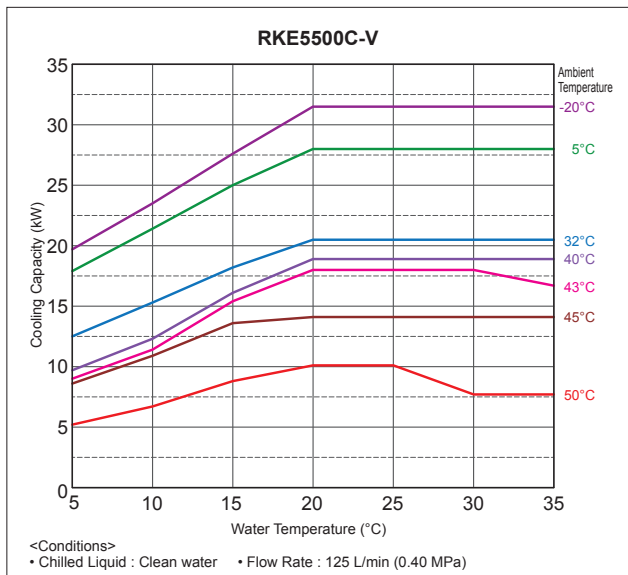
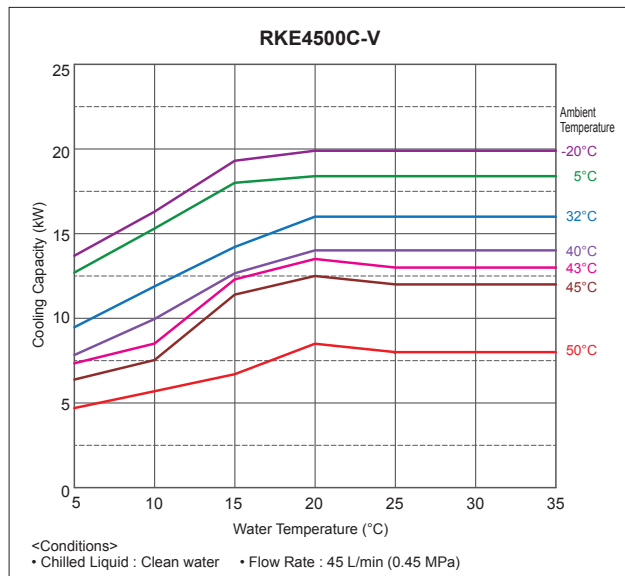
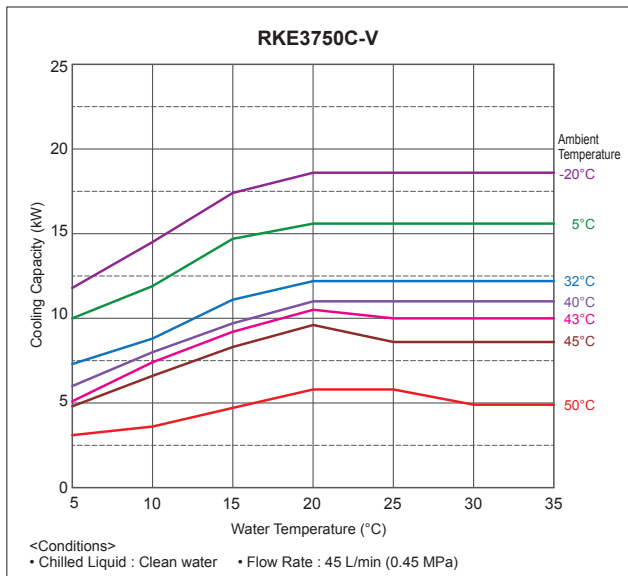

External Dimensions (Units: mm)

RKE3750, 4500C-V

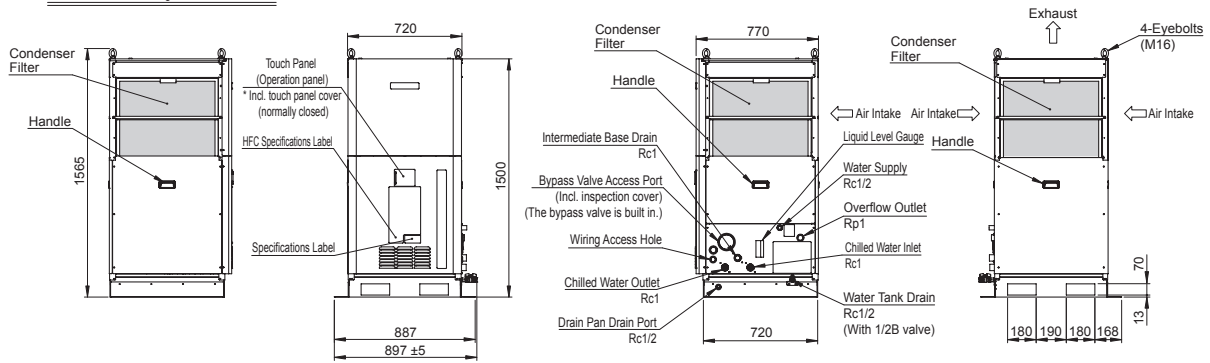
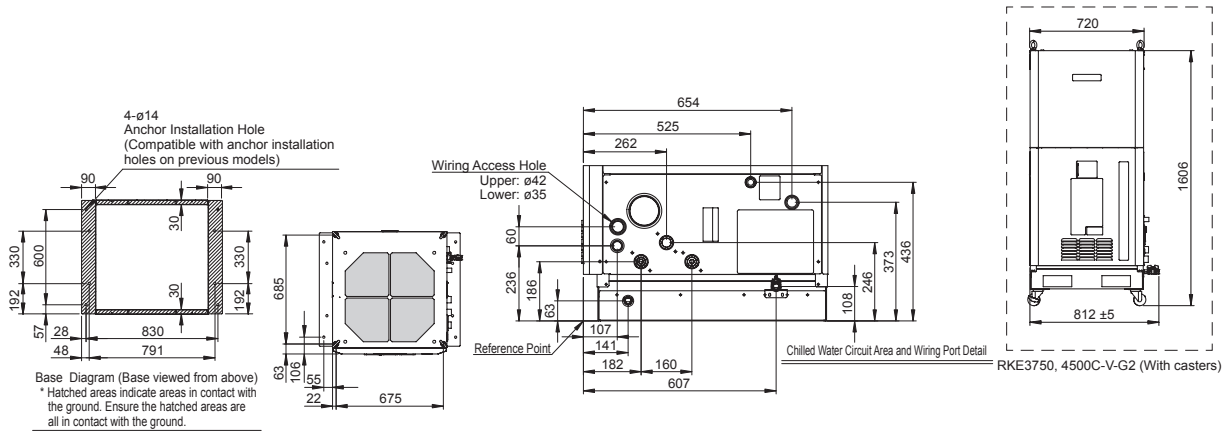

RKE5500C-V

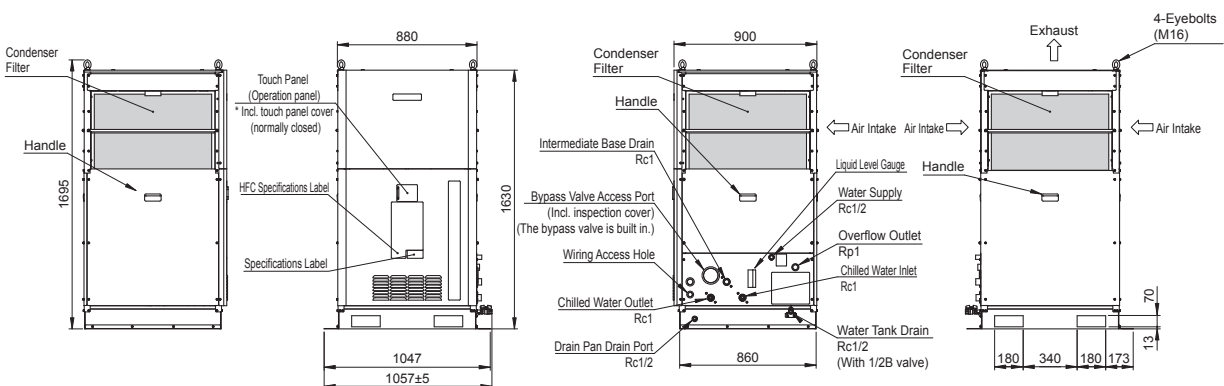
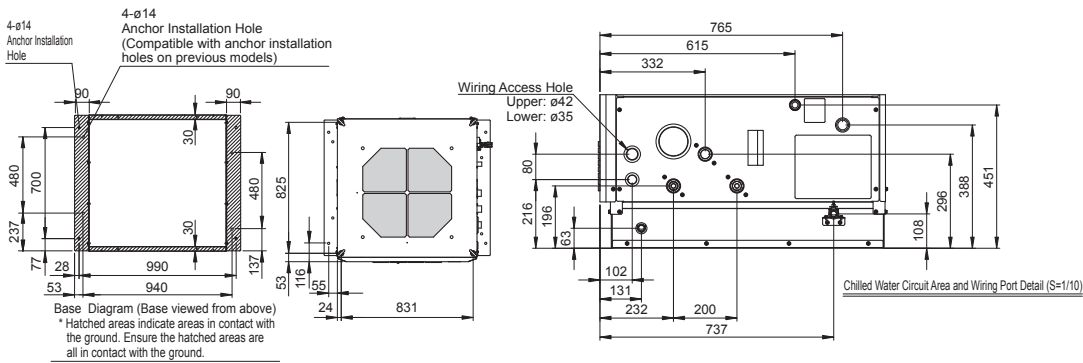

RKE7500, 9000C-V

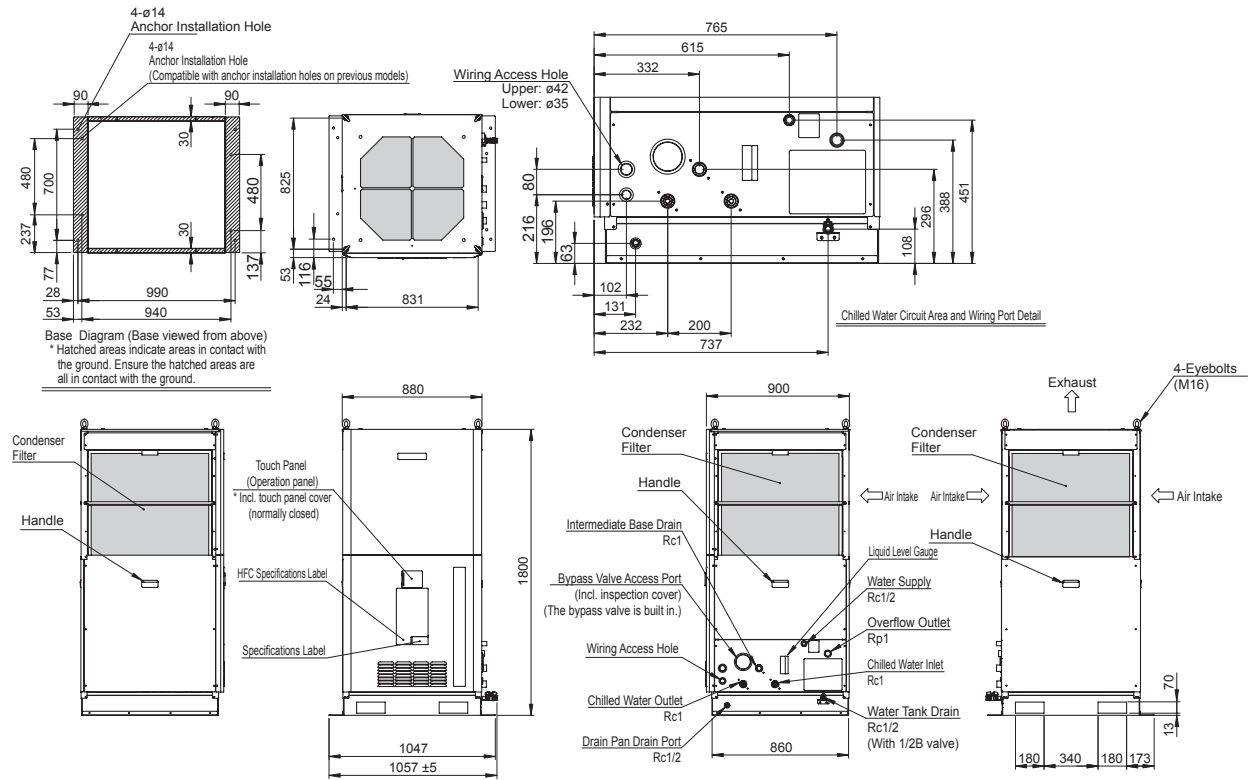

■ Specifications

Model		RKE3750C-VW G1 / G2 (With casters)	RKE5500C-VW	RKE7500C-VW	
Performance Specifications	Cooling Capacity *1	kW	16.0	24.0	30.0
	Legal Refrigeration Tonnage		1.59	2.54	2.92
	Heating Capacity *9	kW	3.0	3.5	4.0
	Operable Ambient Temperature Range *8	°C	2 to 45		
	Cooling Water Temperature Range	°C	5 to 45		
	Operable Liquid Temperature Range	°C	5 to 35 (w/ brine: 0 to 35 *6)		
	Control Precision *4	°C	±0.1 °C *5 (Energy saving mode: ±2.0 °C)		
	Operable Liquid Temperature Range	MPa	0.50		
	Pressure Setting Range	MPa	0.08 to 0.50		
	Operating Flow Rate	L/min	25 to 70	40 to 170	
Power Specifications	Power Source *2	V(Hz)	Three-phase 200 to 220 ±10% (50/60)		
	Power Consumption *1	kW	4.8	6.7	8.4
	Electric Current *1	A	14.8	20.6	26.0
	Power Capacity *3	kVA	6.6	9.5	11.0
Operation Control Method		Compressor speed control			
Equipment Details	Compressor	Construction	Fully sealed rotary type		
		Output	kW	1.85 (Inverter driven)	3.8 (Inverter driven)
	Condenser		Double Pipe Water Cooled		
	Heat Exchanger	Construction	Plate type heat exchanger		
		Material	SUS316 (Brazing: Cu)		
	Discharge Pump	Construction	Multistage centrifugal immersion type		
		Output	kW	1.1 (Inverter driven)	1.5 (Inverter driven)
	Water Tank Capacity *7	L	Approx. 60		
	Refrigerant		R32		
	Charged Amount	kg	1.1	2.0	2.1
External Dimensions (H×D×W)	mm	G1:1650×775×555 G2:1756×775×555	1650×775×555		
Unit Mass (dry weight)	kg	G1:183 G2:188	214	220	
Operating Noise Level *10	dB	62	60	62	

*1 Operating conditions: Chilled water temp.: 20 °C, Ambient temp.: 32 °C. Cooling capacity is at least -5% of listed figures. *2 Source voltage phase unbalance should be less than ±3%. *3 The figure noted is when operating at the highest capacity in the normal operating range. *4 The setting can be changed by changing parameter F015. *5 When the continuous current load fluctuation is within ±10%, and the ambient temperature and power supply, etc. are stable. Does not apply in the following cases: (1) After the compressor starts until the chilled water temperature is stable. (Temperature control will start approx. 1 minute after the compressor starts.) (2) When the refrigeration load is so small such that the compressor is cycling on and off, or the heating-side electronic expansion valve is switching between fully closed to open, or from open to fully closed. When the liquid injection solenoid valve opens or closes. (3) When the current load varies more than ±10%. (4) When the water temperature setting is changed. *6 Brine means a 30 to 50% industrial-use ethylene glycol solution, or 30 to 70% industrial-use propylene glycol solution. *7 When the liquid level gauge is at "F". *8 Not frozen. *9 Only during startup. Will fluctuate depending on the ambient temperature. (Factory default setting: Heating operation: Off) *10 Operating noise levels are from a position of 1 m in front of the product and at a height of 1 m. *11 Operable ambient temperature range will be -20 to 45 °C when the set temperature is below 5 °C (brine must be used).

Note 1: The liquid (chilled water) that can be used with this product is either clean water, a 30% to 50% industrial-use ethylene glycol solution, or a 30 to 70% industrial-use propylene glycol solution. However, also be aware that using one of these solutions can result in a 10% drop in cooling capacity. Also, if using deionized water, ensure that the electrical conductivity is 1 µS/cm or higher.

Note 2: This product contains a refrigerant gas that is slightly flammable. In order to prevent fires in the event of refrigerant gas leakage when the product is installed indoors, provide adequate ventilation and do not allow flames nearby.

■ Cooling Capacity Diagram

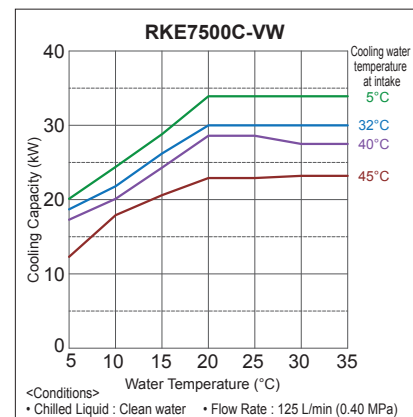
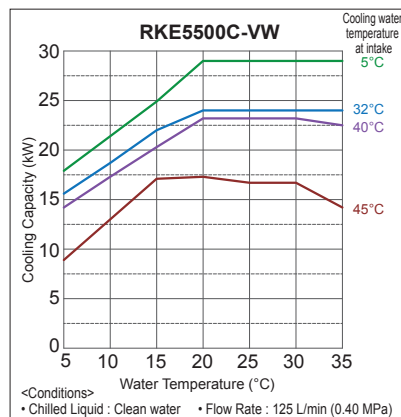
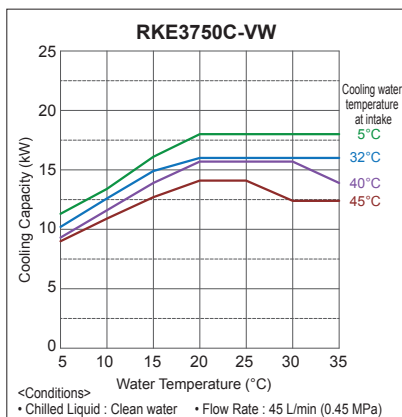

Cooling Water Flow Rate (For the water-cooled condenser)

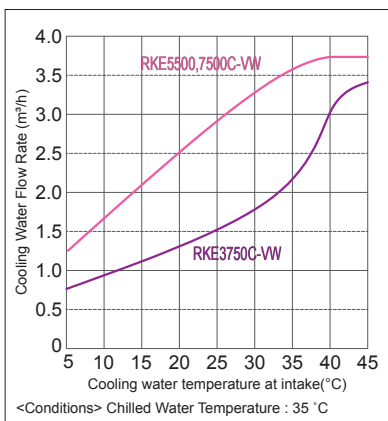

Flow Rate Characteristics Diagram

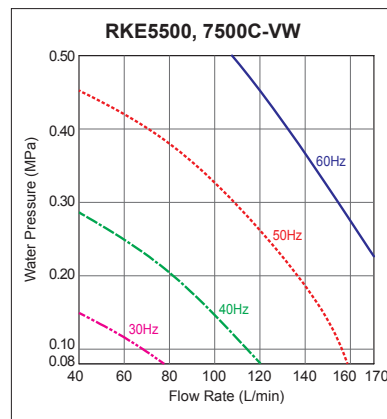
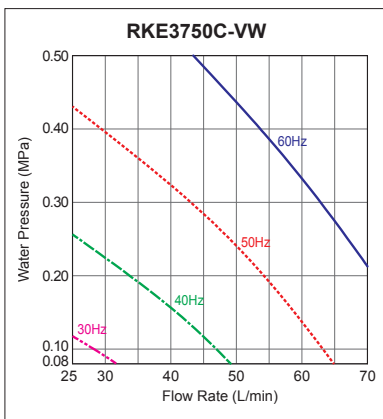

- * The illustration shows the actual measured flow rate value when the bypass valve is closed.
- * Flow rate changes based on inverter frequency.
- * If additives are used, the flow rate characteristics will change due to factors such as the additive used, the concentration, fluid temp, etc.
- * Install valves on the chilled water inlet and outlet ports so that the flow rate and pressure can be adjusted.

External Dimensions (Units: mm)

RKE3750, 5500, 7500C-VW

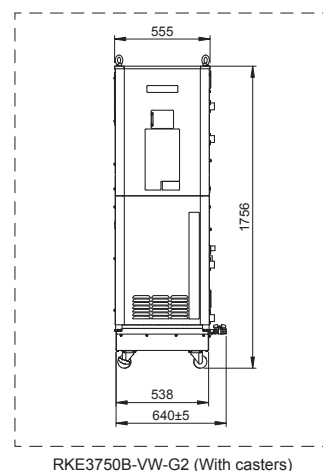
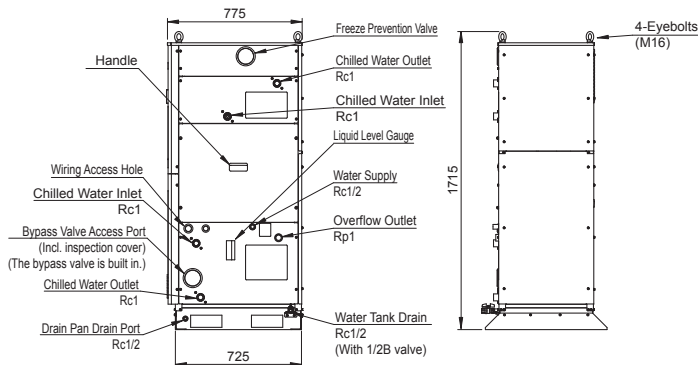
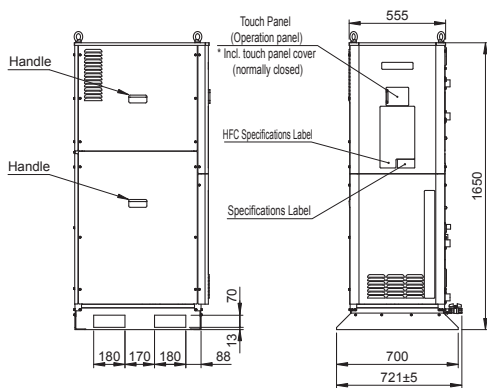
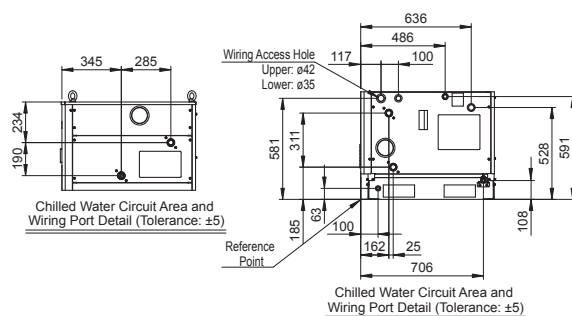
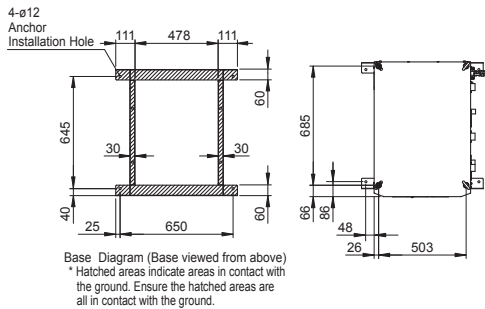

Equipment (Standard / Optional) List Air Cooled

RKE-C Series

		Function
		Item Detail
Operating Environment	Copper-free wetted parts	-
	Operable Ambient Temp. Range	-20 to 50 °C *Operable ambient temperature range will be -20 to 45 °C when the setting temperature is below 5 °C (brine must be used).
	Freeze Prevention Mode	This function operates the discharge pump in order to prevent water temperature drops and freezing during winter months when operation is stopped. When enabled, the discharge pump will operate when the water temperature falls to 3 °C or below.
	Warming-up Mode	This function will automatically operate the discharge pump when the product is otherwise not operating when the ambient temperature is low, for example during winter months, in order to prevent the water temperature from dropping too much and in order to help maintain the set water temperature.
	Snow Protection Mode	When enabled, and when the product is stopped, the fan will periodically and automatically start in order to blow fallen snow from the upper exhaust port.
	Outside Installation	IPX4 Equiv. Rating
	Snow Protection Hood	Prevents falling snow from entering the vent intake.
	Wind/Snow Protection Panel	Consider a wind speed of 8 m/s or higher as a guideline.
	Vibration Isolation Platform	Reduces transmission of vibration from the chiller.
Chilled Water Circuit	Discharge Pump Specs.	Upgrade to a higher grade pump. The operating flow rate cannot be changed from the base model.
	Pressure Relief Valve	Set to maximum working pressure of 0.5 MPa.
	Chilled Water Circuit Water Filter	Water filter A assembly and B assembly
	Water Deionizing Equipment for Chilled Water Circulation Circuit	Deionizing Unit C Assembly and D Assembly
	Water Deionizing Equipment for Chilled Water Supply and Supply Circuits	Water Deionizing Equipment for supply water.
Power Supply and Control Specs	Primary Power Supply Voltage	Three-phase 200 to 220 V (50/60 Hz)
		Three-phase 230 V (50 Hz), 380 V / 400 V / 440 V (50/60 Hz)
	Overload Safety Devices	The product comes with a built in multipurpose overload and short circuit protection breaker.
	Power Outage Recovery Operation Settings	Can choose the recovery pattern after power outage. (Manual recovery / Automatic recovery / Remote operation priority)
	Audible Alarm Enable/Disable	Audible alarm can be enabled or disabled for each audible alarm or warning.
	Communications	USB and RS-422A/485 communications allow operation and setting changes from a remote location. To connect multiple units, set the communication device address number to any number between 0 and 31.
	Remote Control (Wired)	By connecting the remote control, the product can be operated from a remote location, and various settings can be changed as if using the touch panel.
	Remote Control Terminals	Remote Operation (No-voltage contacts)
		Remote discharge pump operation (No-voltage-contact signal)
	Signal Output Terminals	Operation Signal
		Alarm Signal
Temperature warning signal		
Discharge pump operation signal		
Alarm Signal Output Options	Can choose the state of contacts of the remote alarm signal output. (Contacts either ON or OFF during alarm condition.)	
Temperature Warning Signal Output Option	Determines the open/closed state of contacts when a temperature warning signal is present.	
Others	External Surface Coating Thickness	Polyester resin, min. 30 μm
		Polyester resin, min. 45 μm (Salt-corrosion prevention spec.)
	Packaging for Export	Basic plywood packaging
	Heating Functionality	Used to raise the temperature during product startup. (Built-in 200 Vac electric heater.) * ON/OFF control to the set liquid temperature minus 2 ±0.5 °C.
Inspection Manual + Test Results Chart	Japanese	
	English	

Comments	Model				
	3750C-V	4500C-V	5500C-V	7500C-V	9000C-V
Copper alloy is used for wetted parts on standard units.	Manufacturer Option				
Be careful of freezing at low temperatures as well as abnormal temperature rises due to placement in direct sunlight.	Standard				
Can be enabled or disabled via the intelligent touch panel. * Cannot be used at the same time as the warming-up mode.	Standard				
Can be enabled or disabled via the intelligent touch panel. * Cannot be used at the same time as the freeze prevention mode.	Standard				
Can be turned on or off via the intelligent touch panel.	Standard				
Installation in direct sunlight, strong wind (8 m/sec or higher), contact with falling snow, or freezing conditions requires further measures.	Standard				
-	Optional Accessories (Sold separately)				
-	Optional Accessories (Sold separately)				
The vibration isolation platform should be installed on a level full-width foundation with no uneven surfaces. If there is a difference in height of more than 5 mm between the four corners of the vibration isolation platform when the chiller is installed, then adjustment will be required.	Optional Accessories (Sold separately)				
-	Manufacturer Option				
-	Manufacturer Option				
Filtration Rating: 100 µm (5 µm, 10 µm, 20 µm, and 50µm are available as special specification products.) *Operate at or below 0.5 MPa.	Optional Accessories (Sold separately)				
Water Quality: 10 µS/cm or lower	Optional Accessories (Sold separately)				
Including electrical conductivity gauge and flow regulating valve.	Optional Accessories (Sold separately)				
-	Standard				
The transformer can be installed separately. The maximum ambient temperature for the transformer is 45 °C.	Manufacturer Option				
-	Standard				
Action to be taken after recovery can be enabled or disabled via the intelligent touch panel.	Standard				
The audible alarm can be enabled or disabled via the intelligent touch panel.	Standard				
-	Standard				
Max. wiring length: 20 m	Optional Accessories (Sold separately)				
Max. wiring length: 50 m	Optional Accessories (Sold separately)				
Max. wiring length: 100 m	Optional Accessories (Sold separately)				
Max. wiring length: 20 m (w/o cable)	Standard				
No-voltage contacts	Standard				
No-voltage contacts	Standard				
No-voltage contacts	Standard				
No-voltage contacts	Standard				
Can be turned ON or OFF via the intelligent touch panel.	Standard				
The type of relay output (ON/OFF) when an alarm condition occurs can be selected from the intelligent touch panel.	Standard				
-	Standard				
-	Manufacturer Option				
Please consult your dealer regarding JIS standard packaging.	Manufacturer Option				
Heating output: Selectable among 5 kW, or 5 kW × 2	Manufacturer Option				
-	Manufacturer Option				
-	Manufacturer Option				

Equipment (Standard / Optional) List Water Cooled

RKE-C Series

		Function
Item Detail		
Operating Environment	Copper-free wetted parts	-
	Operable Ambient Temp. Range	2 to 45 °C
	Freeze Prevention Mode	This function operates the discharge pump in order to prevent water temperature drops and freezing during winter months when operation is stopped. When enabled, the discharge pump will operate when the water temperature falls to 3 °C or below.
	Warming-up Mode	This function will automatically operate the discharge pump when the product is otherwise not operating when the ambient temperature is low, for example during winter months, in order to prevent the water temperature from dropping too much and in order to help maintain the set water temperature.
	Outside Installation	IPX4 Equiv. Rating
	Cleanroom (Leakage Alarm Spec.)	In addition to the standard specification, leakage sensors, pressure resistant piping, refrigerant piping insulation, and water piping insulation are added.
	Vibration Isolation Platform	Reduces transmission of vibration from the chiller.
Chilled Water Circuit	Discharge Pump Specs.	Upgrade to a higher grade pump. The operating flow rate cannot be changed from the base model.
	Pressure Relief Valve	Set to maximum working pressure of 0.5 MPa.
	Chilled Water Circuit Water Filter	Water filter A assembly and B assembly
	Water Deionizing Equipment for Chilled Water Circulation Circuit	Deionizing Unit C Assembly and D Assembly
	Water Deionizing Equipment for Chilled Water Supply and Supply Circuits	Water Deionizing Equipment for supply water.
Power Supply and Control Specs	Primary Power Supply Voltage	Three-phase 200 to 220 V (50/60 Hz)
		Three-phase 230 V (50 Hz), 380 V / 400 V / 440 V (50/60 Hz)
	Overload Safety Devices	The product comes with a built in multipurpose overload and short circuit protection breaker.
	Power Outage Recovery Operation Settings	Can choose the recovery pattern after power outage. (Manual recovery / Automatic recovery / Remote operation priority)
	Audible Alarm Enable/Disable	Audible alarm can be enabled or disabled for each audible alarm or warning.
	Communications	USB and RS-422A/485 communications allow operation and setting changes from a remote location. To connect multiple units, set the communication device address number to any number between 0 and 31.
	Remote Control (Wired)	By connecting the remote control, the product can be operated from a remote location, and various settings can be changed as if using the touch panel.
	Remote Control Terminals	Remote Operation (No-voltage contacts)
		Remote discharge pump operation (No-voltage-contact signal)
	Signal Output Terminals	Operation Signal
		Alarm Signal
Temperature warning signal		
Discharge pump operation signal		
Alarm Signal Output Options	Can choose the state of contacts of the remote alarm signal output. (Contacts either ON or OFF during alarm condition.)	
Temperature Warning Signal Output Option	Determines the open/closed state of contacts when a temperature warning signal is present.	
Others	External Surface Coating Thickness	Polyester resin, min. 30 μm
		Polyester resin, min. 45 μm (Salt-corrosion prevention spec.)
	Packaging for Export	Basic plywood packaging
	Heating Functionality	Used to raise the temperature during product startup. (Built-in 200 VAC electric heater.) * ON/OFF control to the set liquid temperature minus 2 ±0.5 °C.
Inspection Manual + Test Results Chart	Japanese	
	English	

Comments	Model		
	3750C-VW	5500C-VW	7500C-VW
Copper alloy is used for wetted parts on standard units.	Manufacturer Option		
Be careful of freezing at low temperatures as well as abnormal temperature rises due to placement in direct sunlight.	Standard		
Can be enabled or disabled via the intelligent touch panel. * Cannot be used at the same time as the warming-up mode.	Standard		
Can be enabled or disabled via the intelligent touch panel. * Cannot be used at the same time as the freeze prevention mode.	Standard		
Installation in direct sunlight, strong wind (8 m/sec or higher), contact with falling snow, or freezing conditions requires further measures.	Standard		
Particulate is not taken into account.	Manufacturer Option		
The vibration isolation platform should be installed on a level full-width foundation with no uneven surfaces. If there is a difference in height of more than 5 mm between the four corners of the vibration isolation platform when the chiller is installed, then adjustment will be required.	Optional Accessories (Sold separately)		
-	Manufacturer Option	Special Specification	
-	Manufacturer Option		
Filtration Rating: 100 µm (5 µm, 10 µm, 20 µm, and 50µm are available as special specification products.) *Operate at or below 0.5 MPa.	Optional Accessories (Sold separately)		
Water Quality: 10 µS/cm or lower	Optional Accessories (Sold separately)		
Including electrical conductivity gauge and flow regulating valve.	Optional Accessories (Sold separately)		
-	Standard		
The transformer can be installed separately. The maximum ambient temperature for the transformer is 45 °C.	Manufacturer Option		
-	Standard		
Action to be taken after recovery can be enabled or disabled via the intelligent touch panel.	Standard		
The audible alarm can be enabled or disabled via the intelligent touch panel.	Standard		
-	Standard		
Max. wiring length: 20 m	Optional Accessories (Sold separately)		
Max. wiring length: 50 m	Optional Accessories (Sold separately)		
Max. wiring length: 100 m	Optional Accessories (Sold separately)		
Max. wiring length: 20 m (w/o cable)	Standard		
No-voltage contacts	Standard		
No-voltage contacts	Standard		
No-voltage contacts	Standard		
No-voltage contacts	Standard		
The relay action can be set to ON or OFF via the intelligent touch panel.	Standard		
The type of relay output (ON/OFF) when an alarm condition occurs can be selected from the intelligent touch panel.	Standard		
-	Standard		
-	Manufacturer Option		
Please consult your dealer regarding JIS standard packaging.	Manufacturer Option		
Heating output: Selectable among 5 kW, or 5 kW × 2	Manufacturer Option		
-	Manufacturer Option		
-	Manufacturer Option		

RKE-C Series

Manufacturer Options Table

RKE-C Series Optional Item Numbering Outline

The manufacturer optional item numbers are 6 digits. Please refer to the Optional Item Number Table below and use these numbers when making dealer requests. There are combinations of manufacturer options that may be mutually incompatible. Please refer to the "Manufacturer Optional Item Configuration Table" on pages 23 and 24.

Models

RKE3750C-V(W) +

Manufacturer Optional Item Number



RKE-C Series

1st Digit	2nd Digit	3rd Digit	4th Digit	5th Digit	6th Digit
0: Standard	0: Standard	0: Standard	0: Standard	0: Standard	0: Standard
1: Head specification *1	1: Different voltage (380/400/440 V)	1: Salt-corrosion prevention spec.	1: Incl. relief valve	1: English specification	1: No water tank
2: Casters (with stoppers) *2	2: Incl. heater (5 kW)	2: Incl. pressure equalization piping connection port	2: Cleanroom specification	2: Photo of finished equipment	2: Copperless specification
3: Casters (with adjustable feet)	3: Incl. heaters (5 kW x 2)	3: Salt-corrosion prevention spec. + Incl. pressure equalization piping connection port	3: Incl. relief valve + Cleanroom specification	3: Test results chart (shipped separately) + inspection manual (shipped separately)	3: No water tank + discharge pump removed
4: Packaging for export (plywood siding)			4: Incl. flow gauge	4: English specification + Test results chart (shipped separately) + inspection manual (shipped separately)	
5: Head specification + Casters (with stoppers)			5: Incl. chilled water inlet/outlet valves	5: Test results chart (shipped separately) + inspection manual (shipped separately) + Photo of finished equipment	
6: Head specification + Casters (with adjustable feet)			6: Incl. water filter assembly	6: English specification + Test results chart (shipped separately) + inspection manual (shipped separately) + Photo of finished equipment	
7: Head specification + Packaging for export (plywood siding)			7: Incl. relief valve + Incl. flow gauge		
8: Head specification + Casters (with stoppers) + Packaging for export (plywood siding)			8: Incl. flow gauge + Incl. chilled water inlet/outlet valves + Incl. water filter assembly		
9: Head specification + Casters (with adjustable feet) + Packaging for export (plywood siding)					

*1 Please consult your dealer separately about RKE5500 / 7500C-VW models.

*2 RKE3750C-V(W) and RKE4500C-V models are available with the "-G2 (with caster)" specification.

■ Manufacturer Options Details

Item	Description
Head specification	<ul style="list-style-type: none"> ○ Upgrade to higher grade pump. <p>*The operating flow rate cannot be changed from the base model.</p>
Casters	<ul style="list-style-type: none"> ○ 4 freewheeling casters (with stoppers) ○ 4 freewheeling casters (with adjustable feet)
Packaging for export	<ul style="list-style-type: none"> ○ Simple plywood packaging <p>*Please consult your dealer regarding JIS standard packaging.</p>
Different voltage (380/400/440 V)	<ul style="list-style-type: none"> ○ The transformer can be installed separately. <p>*The maximum ambient temperature of the transformer is 45 °C.</p>
Incl. heater	<ul style="list-style-type: none"> ○ Used to raise the temperature during startup. (Built-in 200 VAC heater) <p>*ON-OFF control at the liquid temperature setting – 2 °C ±0.5 °C. *Choose between a heater capacity of 5 kW or 5 kW x 2.</p>
Salt-corrosion prevention spec	<ul style="list-style-type: none"> ○ Coating film of 45 μm or thicker is used on exterior cabinet surfaces, lower base, and intermediate base. ○ Fan installation bolts: SUS304 ○ Condenser: Corrosion-resistant coating ○ Refrigerant piping: Corrosion-resistant coating ○ Control board and compressor inverter circuit board: Processed with moisture-proof insulation coating. <p>*Differs from the salt damage standards set by the Japan Refrigeration and Air Conditioning Industry Association "JRA".</p>
Incl. pressure equalization piping connection port	<ul style="list-style-type: none"> ○ Pressure equalization piping connection installed. <p>*Pressure equalization piping is required when connecting a chiller with a water tank to the same system.</p>
Incl. relief valve	<ul style="list-style-type: none"> ○ Set to the maximum operating pressure (0.5 MPa).
Cleanroom specification	<ul style="list-style-type: none"> ○ Includes leakage detector (For indoor installations only). ○ Chilled water piping: Insulated, wrapped with insulation tape (excluding level gauge, pump, cooling water piping, and cooling condenser). ○ Insulation material installed on low-temperature refrigerant piping. ○ Removed built-in Eptsealer. ○ Insulation Hose <p>*Does not take particulate into account.</p>
Incl. flow gauge	<ul style="list-style-type: none"> ○ Float type.
Incl. chilled water inlet/outlet valves	<ul style="list-style-type: none"> ○ Ball valves added to the chilled water inlet and outlet ports. <p>*Installed externally.</p>
Incl. water filter assembly	<ul style="list-style-type: none"> ○ RKE3750 / 4500C-V: Water Filter Assembly A ○ RKE5500 / 7500 / 9000C-V: Water Filter Assembly B <p>*Available with a mounting stand for separate installation. *Degree of filtration: 100 μm. (5/10/20/50 μm available as special-specification items.) *Operate at or below 0.5 MPa.</p>
English specification	<ul style="list-style-type: none"> ○ Machine plates and English operating manual
Photo of finished equipment	<ul style="list-style-type: none"> ○ Incl. photo of finished equipment.
Test results chart + inspection manual	<ul style="list-style-type: none"> ○ Documentation produced by ORION.
Copperless specification	<ul style="list-style-type: none"> ○ Modified heat exchanger (SUS brazing)

External Dimensions with Installed Manufacturer Options

■ Configurations Including Manufacture Options that will Modify Base-model External Dimensions [Air-cooled Models] (Units: mm)

When the following manufacturer options are installed, the base width dimension will be increased by 500 mm.

- (11) With Heater (Heater capacity: 5 kW)
- (12) With Heater (Heater capacity: 5 kW × 2)

RKE3750, 4500C-V

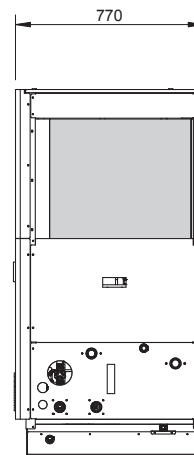
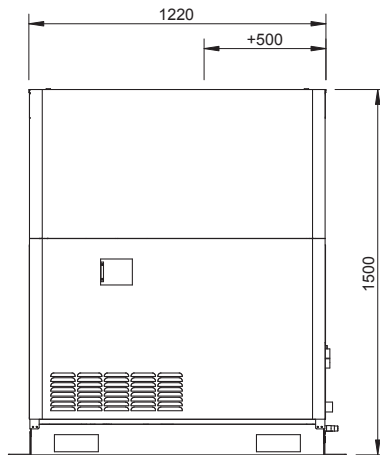
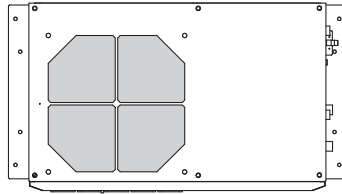

RKE5500C-V

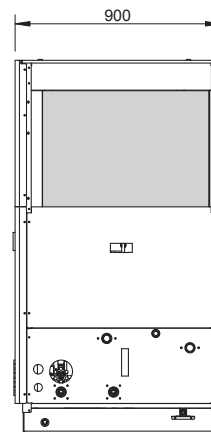
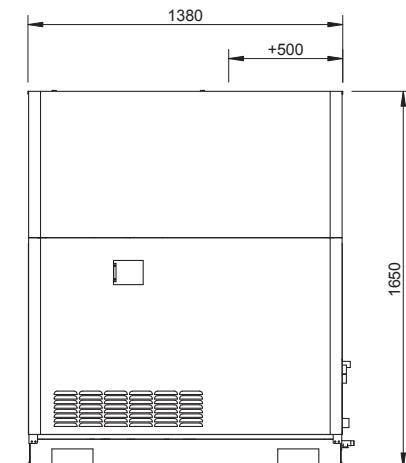
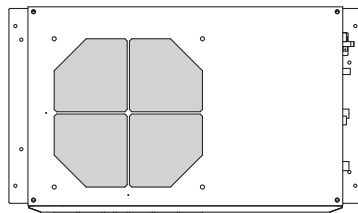

RKE7500, 9000C-V

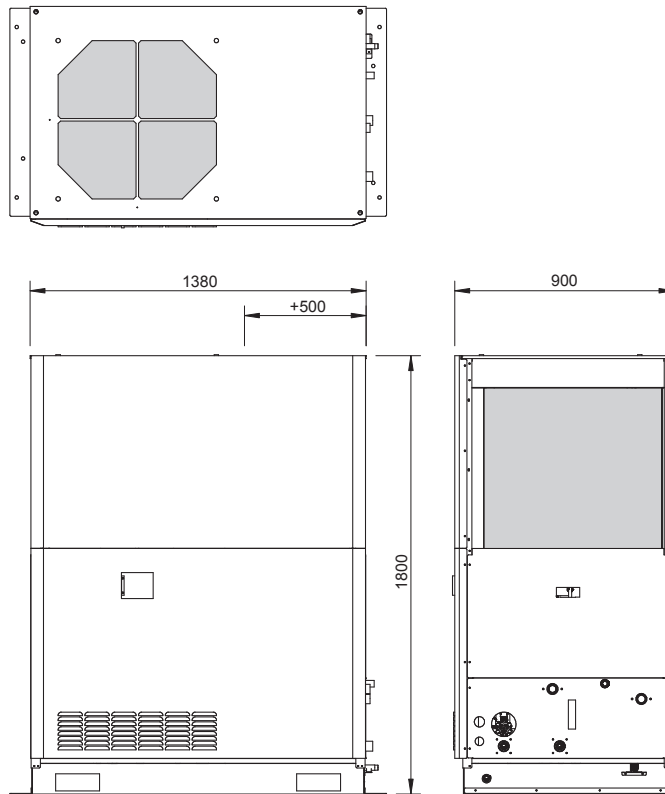

RKE-C Series

■ Configurations Including Manufacture Options that will Modify Base-model External Dimensions [Water-cooled Models] (Units: mm)

The external dimensions will change when the following manufacturer options are installed.

- (11) With Heater (Heater capacity: 5 kW)
- (12) With Heater (Heater capacity: 5 kW×2)
- (24) No Water Tank
- (25) Copperless Specification

RKE3750, 5500, 7500C-VW

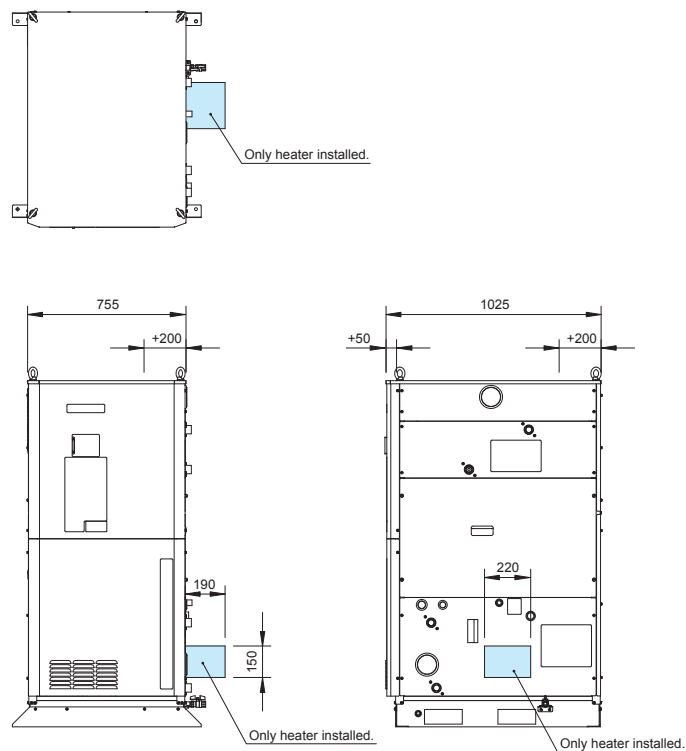

Manufacturer Options Configuration Table

Manufacturer Options		(1)	(2)	(3)	(4)	(5)	(6)	(7)	(8)	(9)
1st Digit	Head specification *1	(1)	x	x	x	x	x	x	x	x
	Casters (with stoppers) *2	(2)	x		x	x	x	x	x	x
	Casters (with adjustable feet)	(3)	x	x		x	x	x	x	x
	Packaging for export (plywood siding)	(4)	x	x	x		x	x	x	x
	Head specification + Casters (with stoppers)	(5)	x	x	x	x		x	x	x
	Head specification + Casters (with adjustable feet)	(6)	x	x	x	x	x		x	x
	Head specification + Packaging for export (plywood siding)	(7)	x	x	x	x	x	x		x
	Head specification + Casters (with stoppers) + Packaging for export (plywood siding)	(8)	x	x	x	x	x	x	x	
	Head specification + Casters (with adjustable feet) + Packaging for export (plywood siding)	(9)	x	x	x	x	x	x	x	x
2nd Digit	Different voltage (380/400/440 V)	(10)	o	o	o	x	o	o	x	x
	Incl. heater (5 kW)	(11)	o	o	o	o	o	o	o	o
	Incl. heaters (5 kW x 2)	(12)	o	o	o	o	o	o	o	o
3rd Digit	Salt-corrosion prevention spec.	(13)	o	o	o	o	o	o	o	o
	Incl. pressure equalization piping connection port	(14)	o	o	o	o	o	o	o	o
	Salt-corrosion prevention spec. + Incl. pressure equalization piping connection port	(15)	o	o	o	o	o	o	o	o
4th Digit	Incl. relief valve	(16)	o	o	o	o	o	o	o	o
	Cleanroom specification	(17)	o	o	o	o	o	o	o	o
	Incl. relief valve + Cleanroom specification	(18)	o	o	o	o	o	o	o	o
	Incl. flow gauge	(19)	o	o	o	o	o	o	o	o
	Incl. chilled water inlet/outlet valves	(20)	o	o	o	o	o	o	o	o
	Incl. water filter assembly	(21)	o	o	o	x	o	o	x	x
	Incl. relief valve + Incl. flow gauge	(22)	o	o	o	o	o	o	o	o
	Incl. flow gauge + Incl. chilled water inlet/outlet valves + Incl. water filter assembly	(23)	o	o	o	x	o	o	x	x
6th Digit	No water tank	(24)	x	o	o	o	x	x	x	x
	Copperless specification	(25)	o	o	o	o	o	o	o	o
	No water tank + discharge pump removed	(26)	x	o	o	o	x	x	x	x

*1 Please consult your dealer separately about RKE5500 / 7500C-VW models.

*2 RKE3750C-V(W) and RKE4500C-V models are available with the "-G2 (with caster)" specification.

*3 5th digit: Documentation-related materials can be combined with any number of digits.

O: Configuration with this option is possible.
 X: Configuration with this option is not possible

	(10)	(11)	(12)	(13)	(14)	(15)	(16)	(17)	(18)	(19)	(20)	(21)	(22)	(23)	(24)	(25)	(26)
	O	O	O	O	O	O	O	O	O	O	O	O	O	O	X	O	X
	O	O	O	O	O	O	O	O	O	O	O	O	O	O	O	O	O
	O	O	O	O	O	O	O	O	O	O	O	O	O	O	O	O	O
	X	O	O	O	O	O	O	O	O	O	O	X	O	X	O	O	O
	O	O	O	O	O	O	O	O	O	O	O	O	O	O	X	O	X
	O	O	O	O	O	O	O	O	O	O	O	O	O	O	X	O	X
	X	O	O	O	O	O	O	O	O	O	O	X	O	X	X	O	X
	X	O	O	O	O	O	O	O	O	O	O	X	O	X	X	O	X
	X	O	O	O	O	O	O	O	O	O	O	X	O	X	X	O	X
		X	X	O	O	O	O	O	O	O	O	O	O	O	O	O	O
	X		X	O	O	O	O	O	O	O	O	O	O	O	X	O	X
	X	X		O	O	O	O	O	O	O	O	O	O	O	X	O	X
	O	O	O		X	X	O	O	O	O	O	O	O	O	O	O	O
	O	O	O	X		X	O	O	O	O	O	O	O	O	X	O	X
	O	O	O	X	X		O	O	O	O	O	O	O	O	X	O	X
	O	O	O	O	O	O		X	X	X	X	X	X	X	X	X	X
	O	O	O	O	O	O	X		X	X	X	X	X	X	O	O	O
	O	O	O	O	O	O	X	X		X	X	X	X	X	X	X	X
	O	O	O	O	O	O	X	X	X		X	X	X	X	O	X	O
	O	O	O	O	O	O	X	X	X	X		X	X	X	O	X	O
	O	O	O	O	O	O	X	X	X	X	X		X	X	O	X	O
	O	O	O	O	O	O	X	X	X	X	X	X		X	X	X	X
	O	O	O	O	O	O	X	X	X	X	X	X	X		O	X	O
	O	X	X	O	X	X	X	O	X	O	O	O	X	O		X	X
	O	O	O	O	O	O	X	O	X	X	X	X	X	X	X		X
	O	X	X	O	X	X	X	O	X	O	O	O	X	O	X	X	

Accessory List (These items sold separately)

RKE-C Air Cooled

Item	Description
Wind / Snow Protection Panel *1	Mitigates the effects of strong wind (8 m/s or higher) on the product.
Snow Protection Hood	Helps prevent snow from collecting on the vent intake.
Vibration Isolation Platform *2	Reduces transmission of vibration from the chiller.
Remote Control Set (Includes 20 m remote control cable)	By connecting the remote control, the product can be operated from a remote location, and various settings can be changed as if using the touch panel.
Remote Control Set (Includes 50 m remote control cable)	
Remote Control Set (Includes 100 m remote control cable)	
Caster Option A Set	4 freewheeling casters with stoppers
Caster Option B Set	4 freewheeling casters with adjustable feet
Caster Option C Set	2 freewheeling feet with stoppers and 2 fixed casters
Water Filter "A" Assembly *3	Filtration Rating: 100 µm (5µm, 10µm, 20µm, and 50µm are available as special specification items.)
Water Filter "B" Assembly *3	
Deionizing unit "C" Assembly	Water Quality: 10 µS/cm or lower
Deionizing unit "D" Assembly	
Water deionizing assembly for supply water.	Including electrical conductivity gauge and flow regulating valve.
LAN Board Set	Used when connecting a LAN cable.
Noise-reduction Kit	Attaches to the compressor to reduce noise.

*1. If the Wind/Snow Protection Panel is to be installed on 3 intake faces, then 3 panel sets are required.

*2. The vibration isolation platform should be installed on a level full-width foundation with no uneven surfaces. If there is a difference in height of more than 5 mm between the four corners of the vibration isolation platform when the chiller is installed then adjustment will be required.

*3. Operate at or below 0.5 MPa.

RKE-C Water Cooled

Item	Description
Vibration Isolation Platform *1	Reduces transmission of vibration from the chiller.
Remote Control Set (Includes 20 m remote control cable)	By connecting the remote control, the product can be operated from a remote location, and various settings can be changed as if using the touch panel.
Remote Control Set (Includes 50 m remote control cable)	
Remote Control Set (Includes 100 m remote control cable)	
Caster Option A Set	4 freewheeling casters with stoppers
Caster Option B Set	4 freewheeling casters with adjustable feet
Caster Option C Set	2 freewheeling feet with stoppers and 2 fixed casters
Water Filter "A" Assembly *2	Filtration Rating: 100 µm (5µm, 10µm, 20µm, and 50µm are available as special specification items.)
Water Filter "B" Assembly *2	
Deionizing unit "C" Assembly	Water Quality: 10 µS/cm or lower
Deionizing unit "D" Assembly	
Water deionizing assembly for supply water.	Including electrical conductivity gauge and flow regulating valve.
LAN Board Set	Used when connecting a LAN cable.
Noise-reduction Kit	Attaches to the compressor to reduce noise.

*1. The vibration isolation platform should be installed on a level full-width foundation with no uneven surfaces. If there is a difference in height of more than 5 mm between the four corners of the vibration isolation platform when the chiller is installed then adjustment will be required.

*2. Operate at or below 0.5 MPa.



Wind / Snow Protection Panel



Snow Protection Hood



Noise-reduction Kit

*The photo shows installation on the RKE3750C-V(W) / 4500C-V models.

	RKE3750C-V	RKE4500C-V	RKE5500C-V	RKE7500C-V	RKE9000C-V
	03300345010		03300454010		03300340010
	03300356010				03300366010
	0A005788000				0A005789000
			03115537010		
			03115537020		
			03115537030		
	03300438010				03300441010
	03300439010				03300442010
	03300440010				03300443010
	04100489010				-
	-				04100491010
	04100614010				-
	-				04100597010
			04100522010		
			04112328010		
	03300452010				03300453010

RKE-C Series

	RKE3750C-VW	RKE5500C-VW	RKE7500C-VW
		0A005801000	
		03115537010	
		03115537020	
		03115537030	
		03300463010	
		03300464010	
		03300465010	
	04100489010		-
	-		04100491010
	04100614010		-
	-		04100597010
		04100522010	
		04112328010	
	03300452010		03300453010



Remote Control Set



Deionizing unit "C" Assembly



Water deionizing assembly for supply water

External Dimensions with Installed Accessories

■ Wind / Snow Protection Panel (Units: mm)

RKE3750, 4500C-V

1. Wind/Snow Protection Panel Assembly Number: 03300345010
 *The illustration shows an installation with 3 Wind/Snow Protection Panel sets installed.

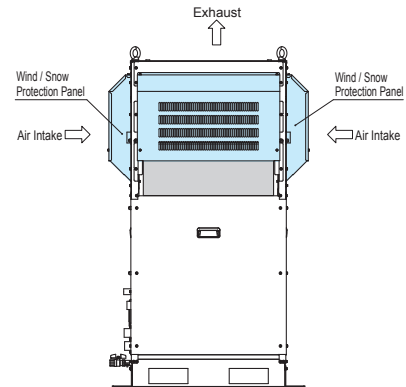
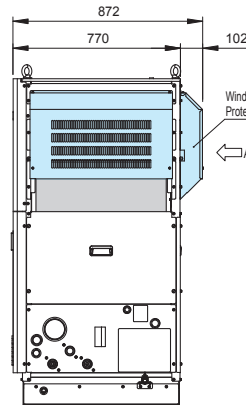
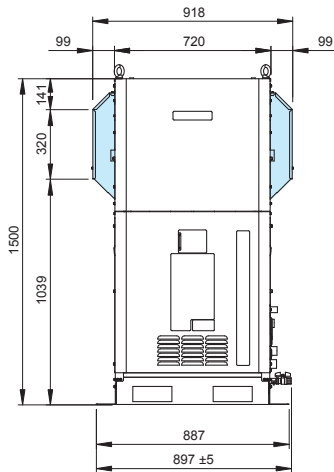
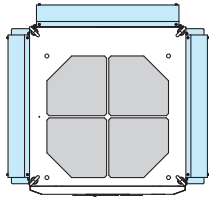

RKE-C Series

RKE5500C-V

1. Wind/Snow Protection Panel Assembly Number: 03300454010
 *The illustration shows an installation with 3 Wind/Snow Protection Panel sets installed.

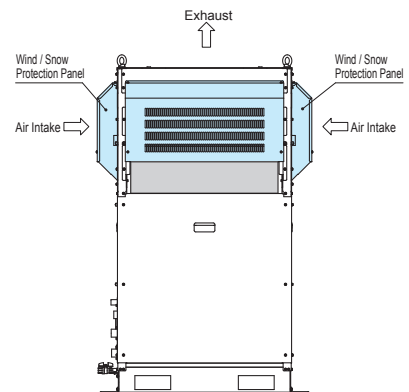
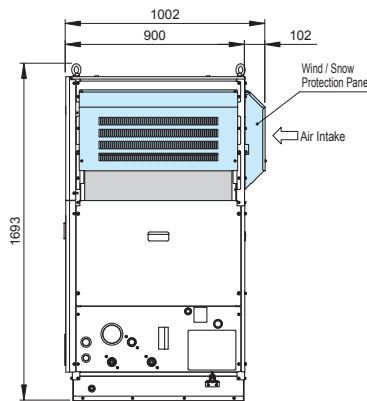
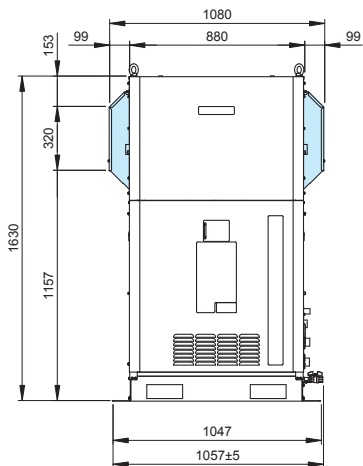
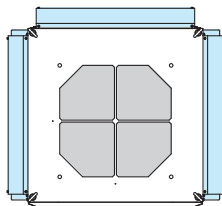

RKE7500, 9000C-V

1. Wind/Snow Protection Panel Assembly Number: 03300340010
 *The illustration shows an installation with 3 Wind/Snow Protection Panel sets installed.

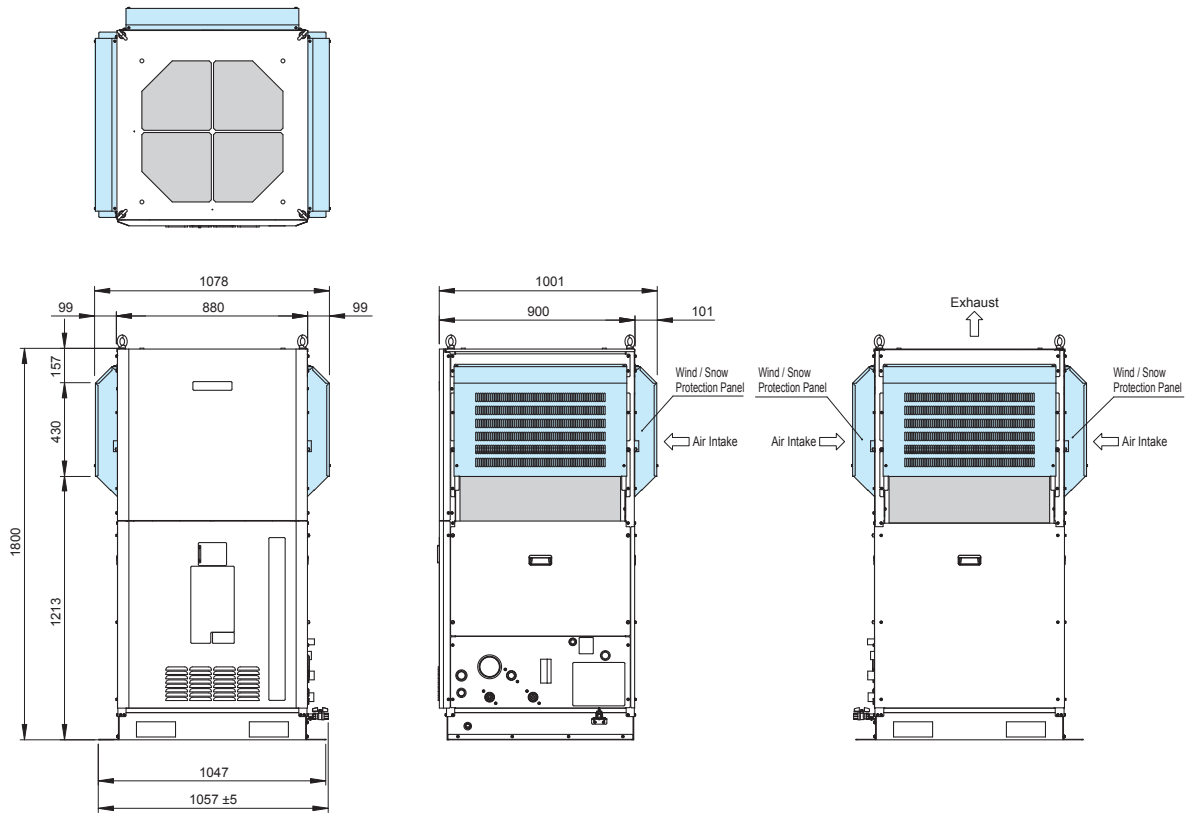

RKE-C Series

External Dimensions with Installed Accessories

Snow Protection Hood (Units: mm)

RKE3750, 4500C-V

1. Snow Protection Hood Assembly Part Number: 03300356010

RKE-C Series

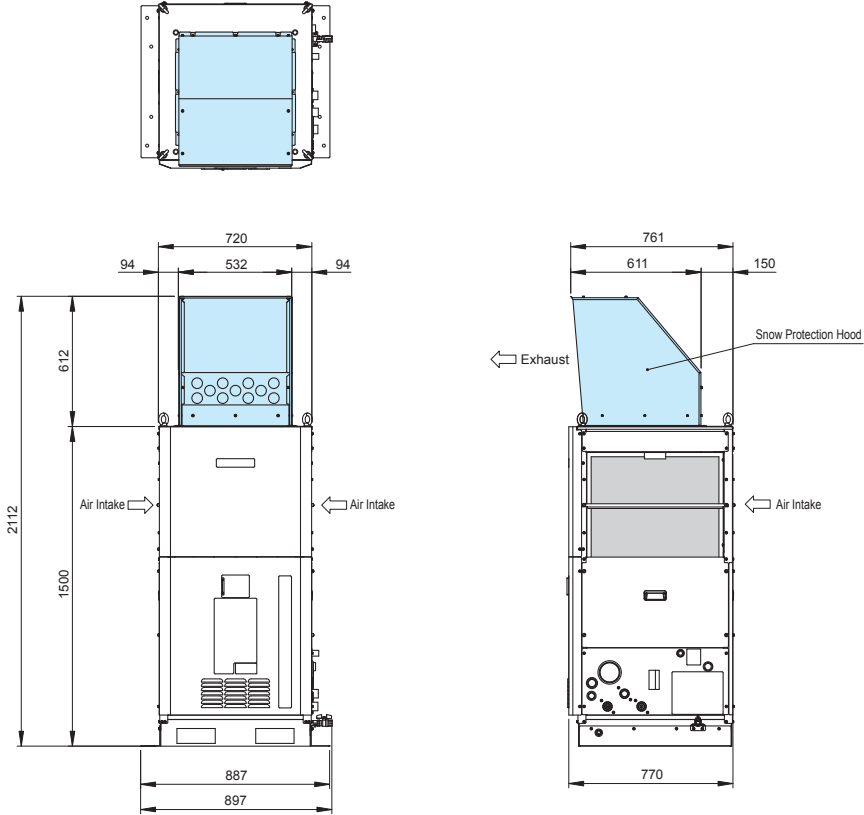

RKE5500C-V

1. Snow Protection Hood Assembly Part Number: 03300366010

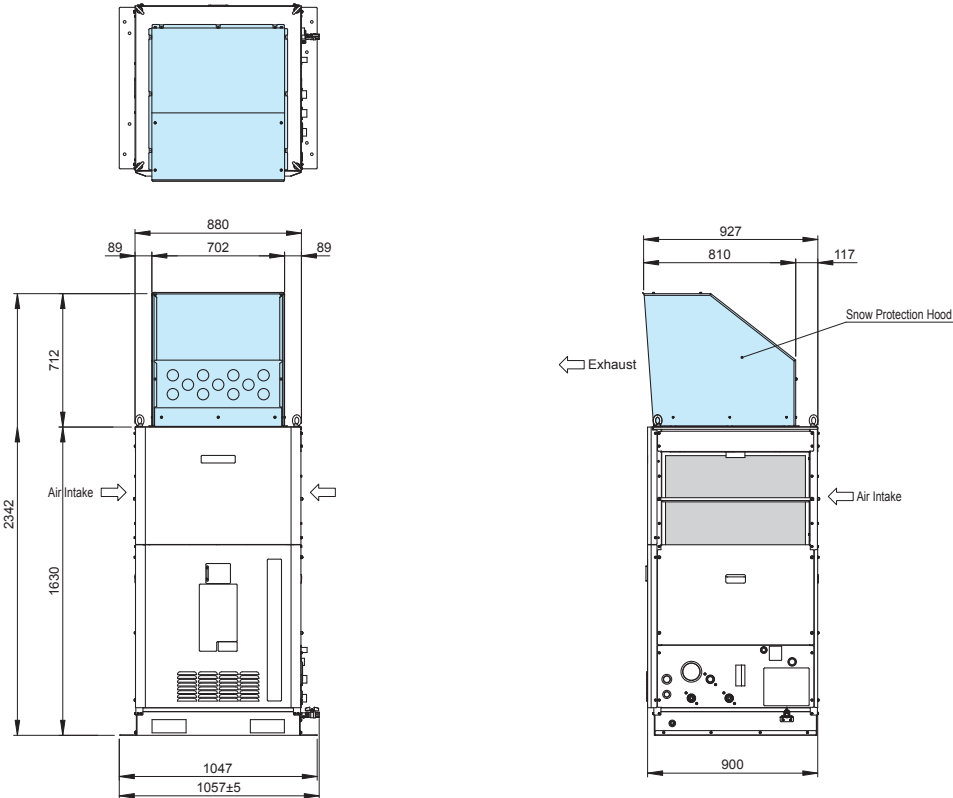

RKE7500, 9000C-V

1. Snow Protection Hood Assembly Part Number: 03300366010

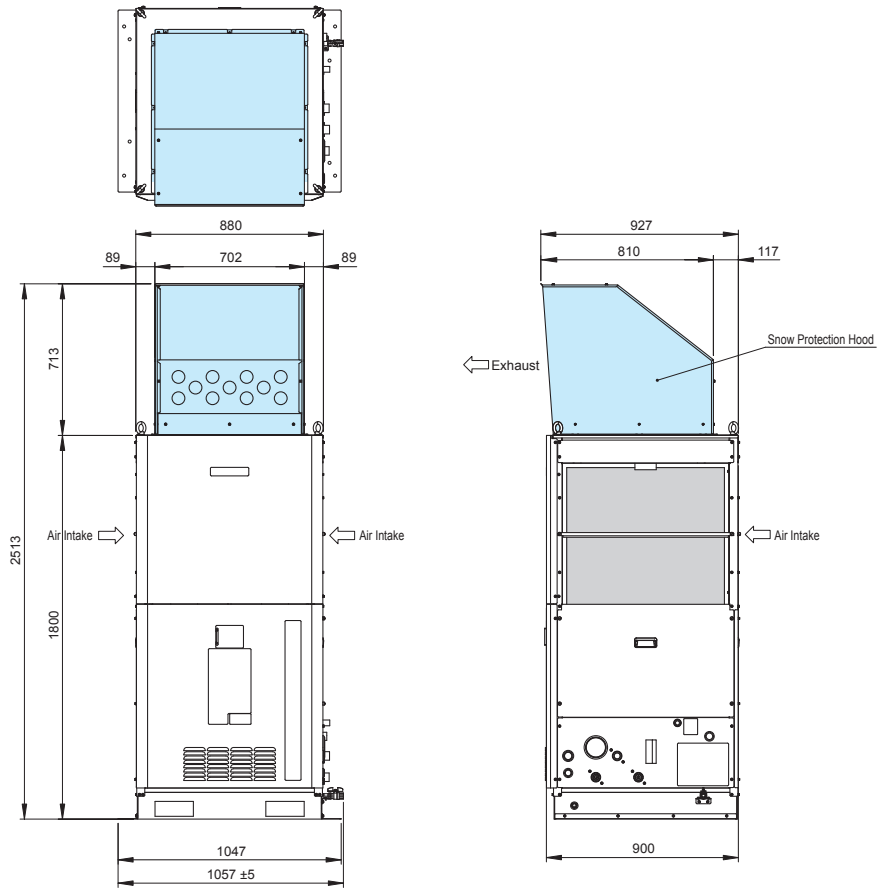

RKE-C Series

External Dimensions with Installed Accessories

Snow Protection Hood and Wind/Snow Protection Panel Configuration (Units: mm)

RKE3750, 4500C-V

1. Snow Protection Hood Assembly Part Number: 03300356010
 2. Wind/Snow Protection Panel Assembly Number: 03300345010
 *The illustration shows an installation with 3 Wind/Snow Protection Panel sets installed.

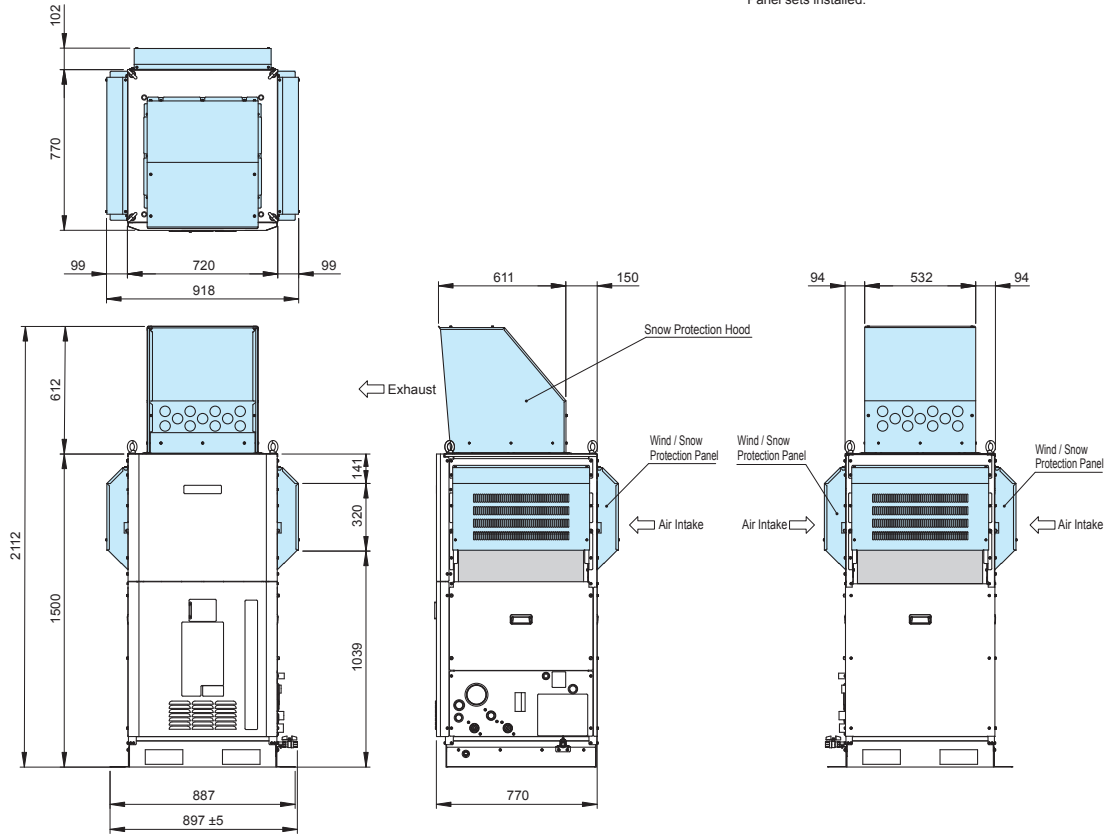

RKE5500C-V

1. Snow Protection Hood Assembly Part Number: 03300366010
 2. Wind/Snow Protection Panel Assembly Number: 03300454010
 *The illustration shows an installation with 3 Wind/Snow Protection Panel sets installed.

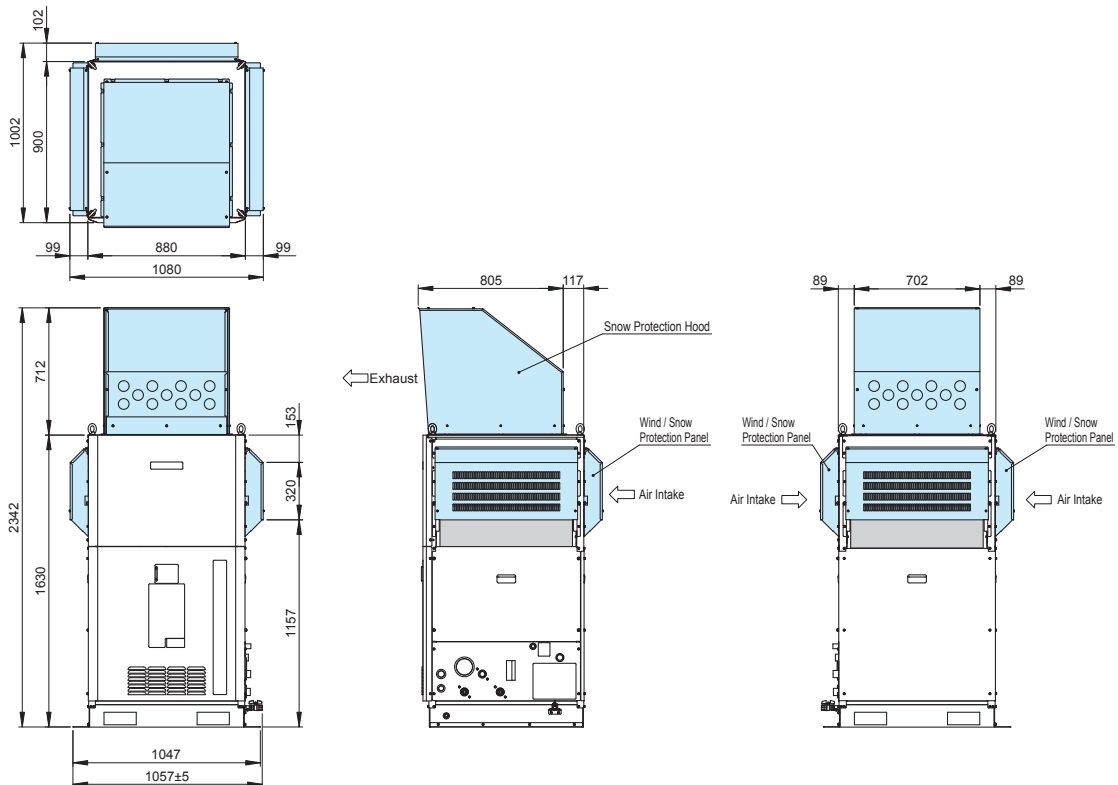

RKE7500, 9000C-V

1. Snow Protection Hood Assembly Part Number: 03300366010
 2. Wind/Snow Protection Panel Assembly Number: 03300340010
 *The illustration shows an installation with 3 Wind/Snow Protection Panel sets installed.

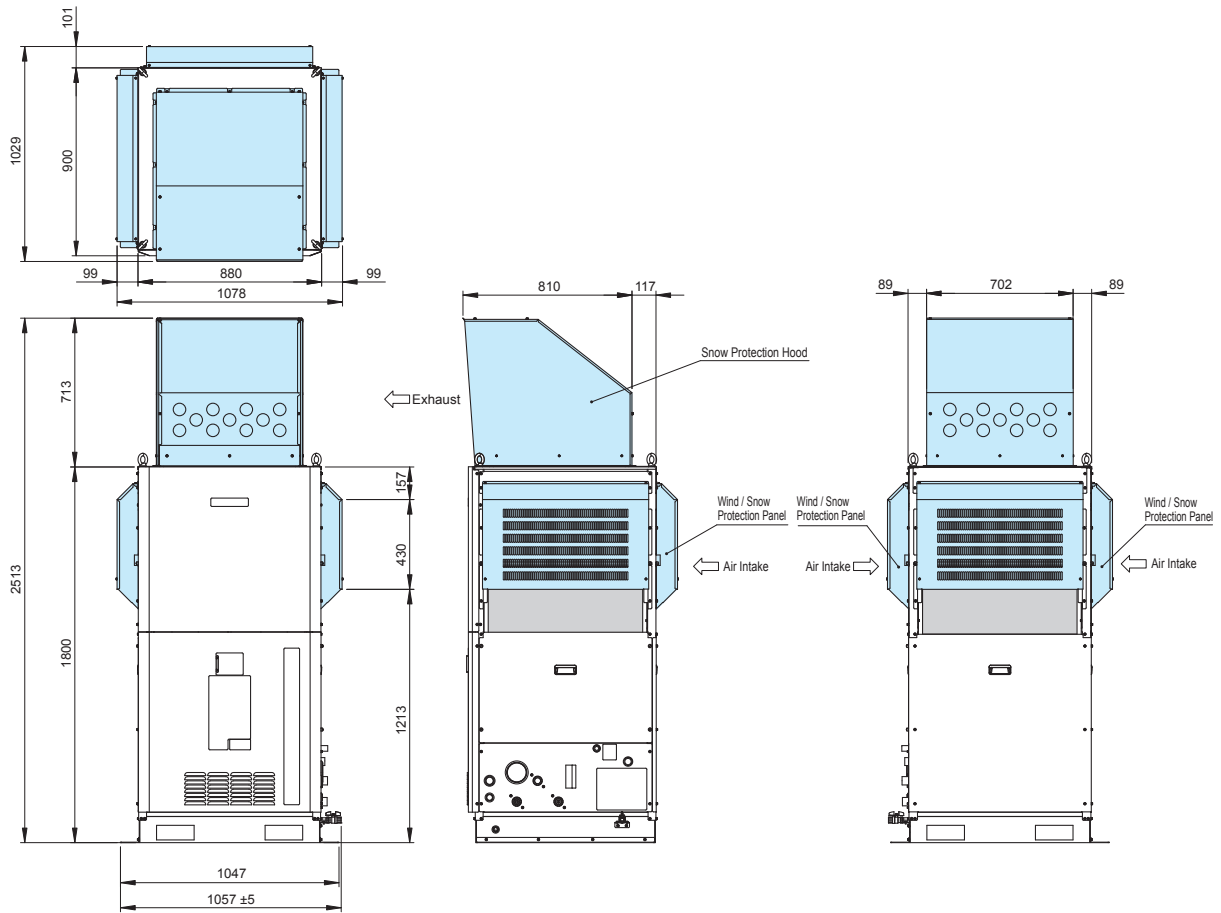

RKE-C Series

External Dimensions with Installed Accessories

Vibration Isolation Platform (Units: mm)

RKE3750, 4500C-V

1. Vibration Isolation Platform Part Number: 0A005788000

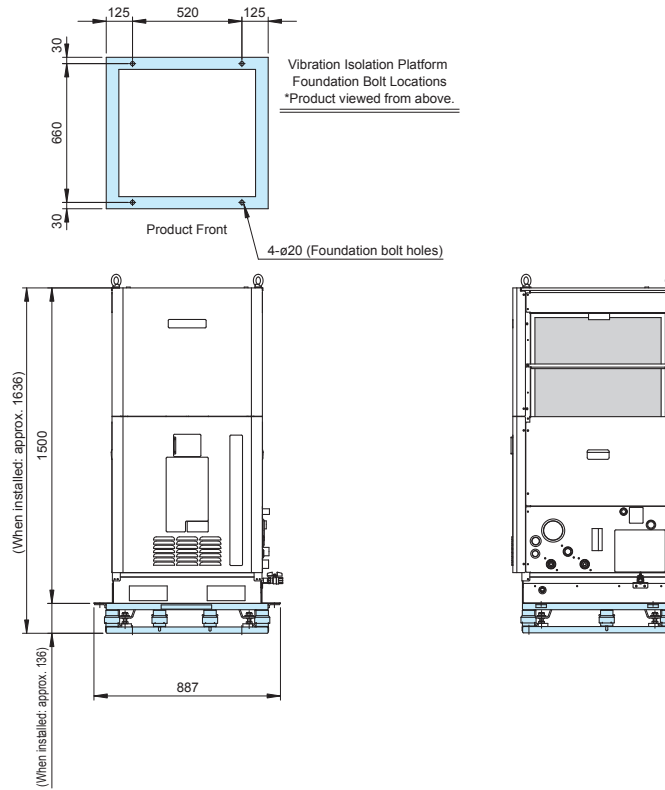

RKE5500C-V

1. Vibration Isolation Platform Part Number: 0A005789000

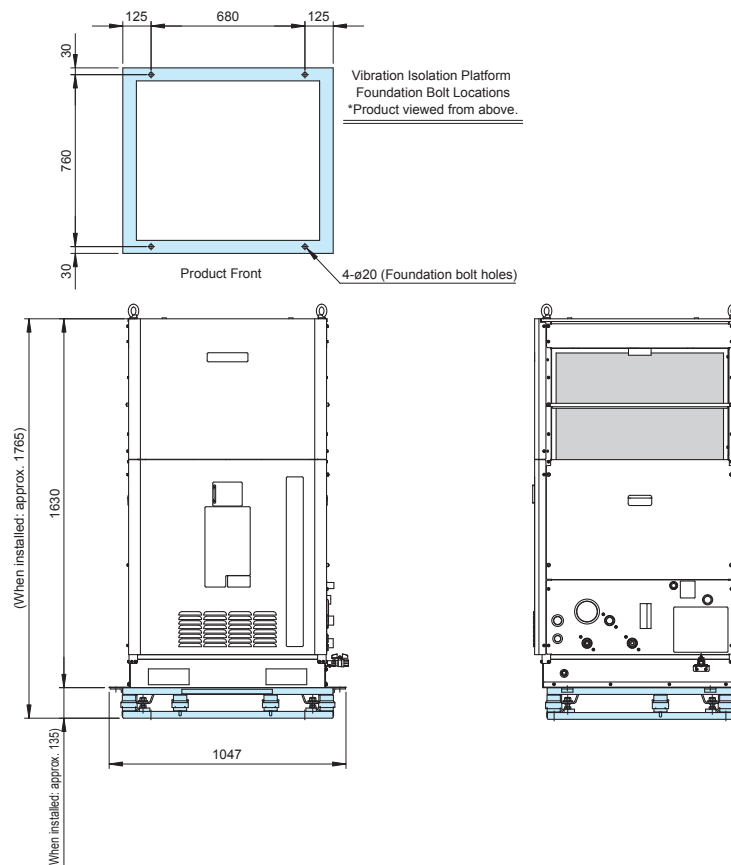

RKE7500, 9000C-V

1. Vibration Isolation Platform Part Number: 0A005789000

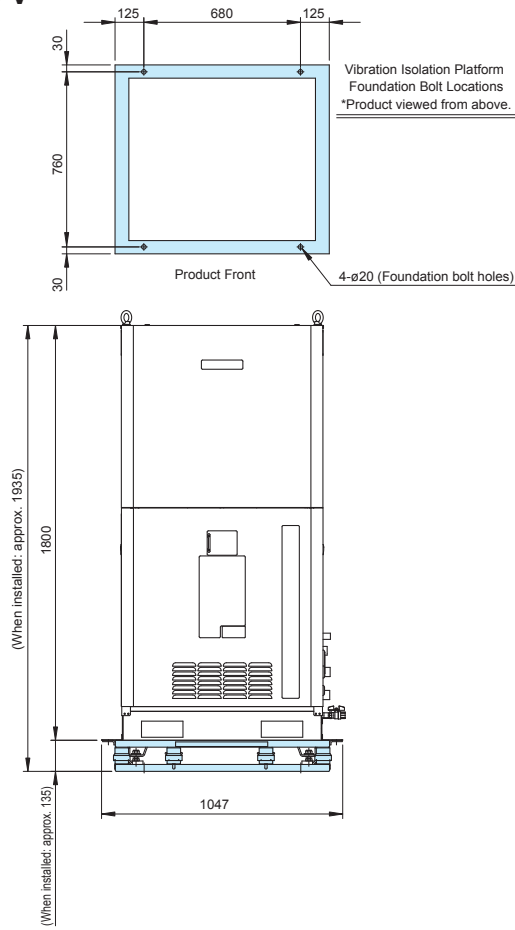

RKE3750, 5500, 7500C-VW

1. Vibration Isolation Platform Part Number: 0A005801000

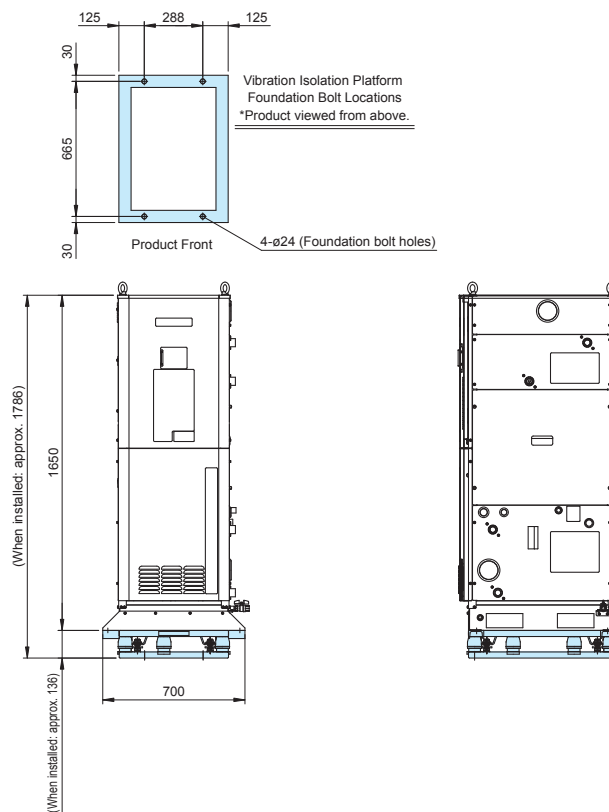

External Dimensions with Installed Accessories

■ **Caster Option A Assembly (4 freewheeling casters with stoppers) and C Assembly (2 freewheeling casters with stoppers and 2 fixed casters) (Units: mm)**

RKE-C Series

RKE3750, 4500C-V

1. Caster Option A Assembly Part Number: 03300438010
2. Caster Option C Assembly Part Number: 03300440010

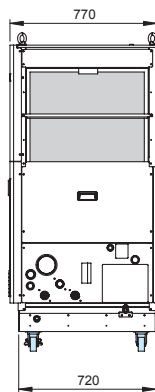
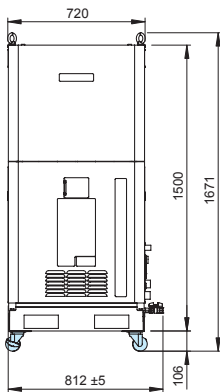
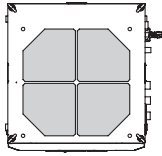

RKE5500C-V

1. Caster Option A Assembly Part Number: 03300441010
2. Caster Option C Assembly Part Number: 03300443010

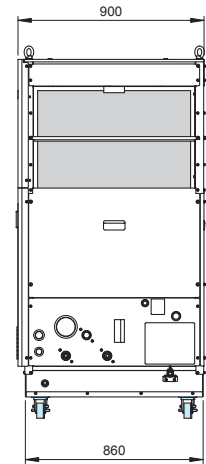
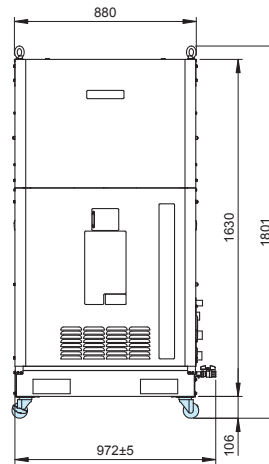
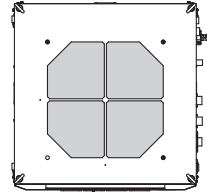

RKE7500, 9000C-V

1. Caster Option A Assembly Part Number: 03300441010
2. Caster Option C Assembly Part Number: 03300443010

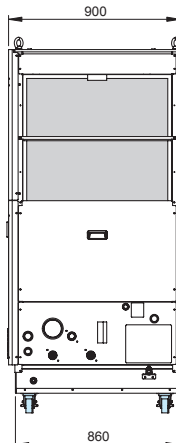
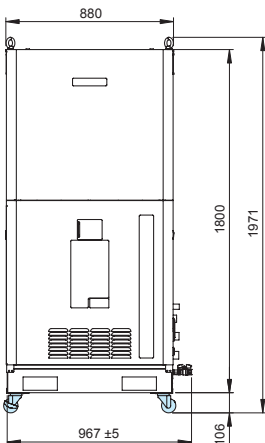
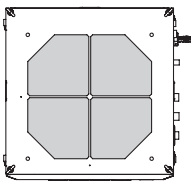

RKE3750, 5500, 7500C-VW

1. Caster Option A Assembly Part Number: 03300463010
2. Caster Option C Assembly Part Number: 03300465010

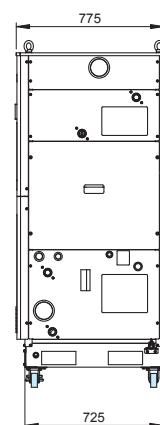
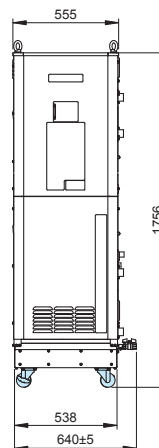
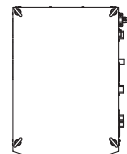

■ Caster Option B Assembly (4 freewheeling casters with adjustable feet) (Units: mm)

RKE3750, 4500C-V

1. Caster Option B Assembly Part Number: 03300439010

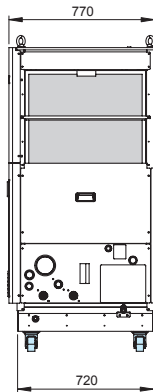
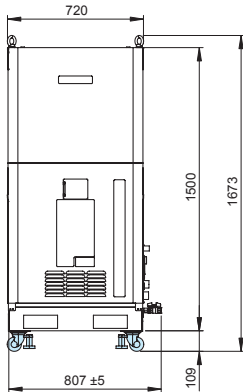
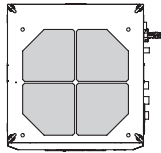

RKE5500C-V

1. Caster Option B Assembly Part Number: 03300442010

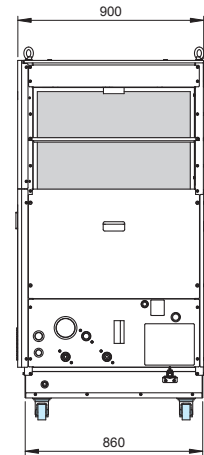
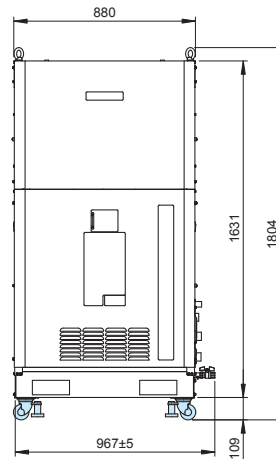
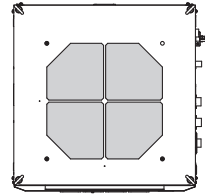

RKE7500, 9000C-V

1. Caster Option B Assembly Part Number: 03300442010

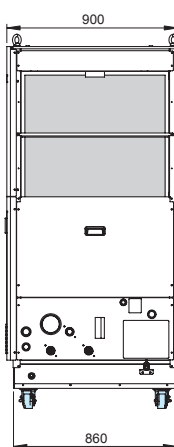
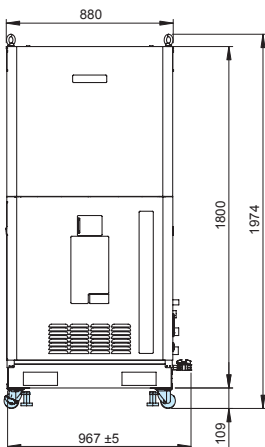
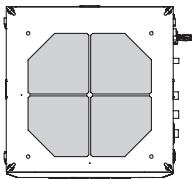

RKE3750, 5500, 7500C-VW

1. Caster Option B Assembly Part Number: 03300464010

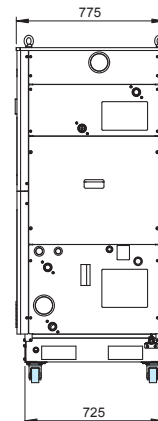
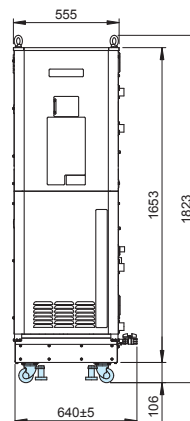
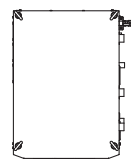

RKE-C Series

RKE-B Series

Air Cooled Water Cooled

Cooling Capacity	37.2 to 96.0 kW	Operable Liquid Temperature Range	3 to 35 °C
Operable Ambient Temperature Range	-20 to 45 °C(Air Cooled) 2 to 45 °C(Water Cooled)	Refrigerant	R410A

Models	RKE11000B1-V(W)
	RKE15000B-V(W)
	RKE22000B-V
	RKE30000B-V

IPX4 Equiv. Rating: Splash-proof Bypass Valve Included as Standard Equipment

HFC Refrigerant	Air Cooled	Water Cooled	Inverter (TESC)
Intelligent Touch Panel	Low Noise Operation	IoT* *See page 73.	IPX4 Equiv. Rating: Splash-proof

Carefree 2-year Warranty
* Warranty period of the refrigerant circuit is 2 years from the date of purchase (or 10,000 hours of operating time).



RKE-B Series

Built-in TESC realizes high precision control with minimal power consumption.

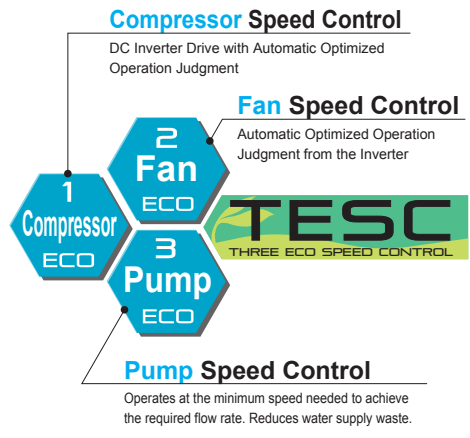

Selectable Pump Control Method
Can set operating frequency, flow rate*, or water pressure.

Discharge Pump Control Method Options

* The displayed flow rate is a calculated value. The actual flow rate may differ.

Intelligent Touch Panel

Various settings and operating conditions can be visually and intuitively checked and operated via the touch panel controller.

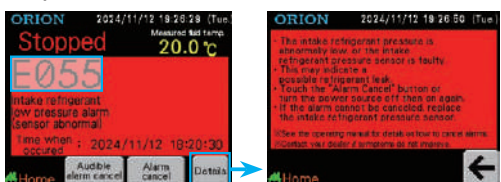
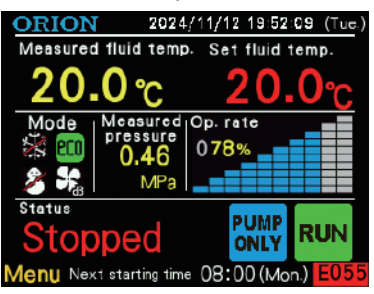

Alarm numbers are displayed when alarm conditions occur. Alarm details and troubleshooting advice can be brought up from by touching the "Details" (on 22000 and 30000 models when "Alarm" is displayed).

The displayed language can be changed to English, Japanese or Chinese.

Japanese language mode

Chinese language mode

Increased Operating Ambient Temperature Range

Greatly increased operable ambient temperature range compared to conventional chillers. Ambient temperatures up to 50 °C possible with the installation of an optional accessory. Use with confidence even as outside air temperatures rise year by year due to global warming.

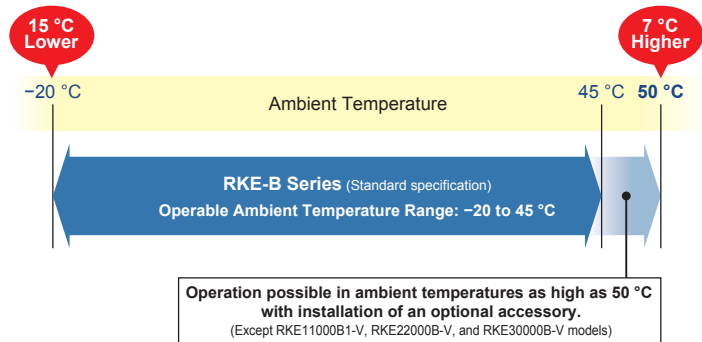

Low Operating Noise Design

Ideal inverter fan speed control through optimized refrigeration cycle control. Achieves much lower operating noise levels.

* Operating noise measured from a distance of 1 m from the front of the product at a height of 1 m.



RKE11000B1-V/VW	69dB / 61dB
RKE15000B-V/VW	68dB / 59dB

RKE22000B-V	63dB
RKE30000B-V	64dB

RKE-B Series

Supports linking of multiple units. As many as 4 units can be connected.

* Compatible with RKE22000 and 30000B-V models.

Using our Central Chiller Controller*, centralized operation of up to 16 units is possible.

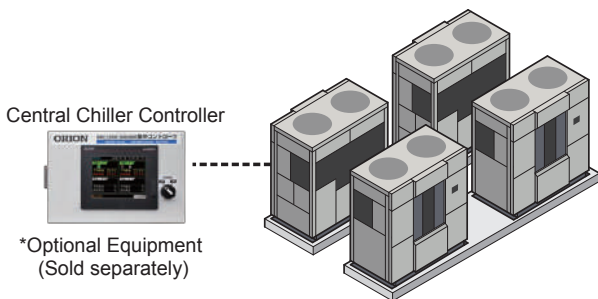

*Optional Equipment (Sold separately)

Linked Model Example (Number of units)

HP	Cooling capacity (kW)	RKE22000B-V (30HP)	RKE30000B-V (40HP)
30	74	1	-
40	96	-	1
60	148	2	-
80	192	-	2
90	222	3	-
120	288	-	3
160	384	-	4

Specifications

Model		RKE11000B1-V	RKE15000B-V	RKE22000B-V	RKE30000B-V			
Performance Specifications	Cooling Capacity *1	kW		37.2	48.0	74.4	96.0	
	Legal Refrigeration Tonnage			3.96	4.95	7.23	9.90	
	Heating Capacity *8	kW		8.0	10.0	16	20	
	Operable Ambient Temperature Range	°C		-20 to 45	-20 to 45 (-20~50 with an accessory, sold separately)	-20 to 45		
	Operable Liquid Temperature Range	°C		3 to 35 (w/ brine: 0 to 35) *7				
	Control Precision *4			±0.1 °C (Energy saving mode: ±2.0 °C)				
Operating Flow Rate		L/min		100 to 230		200 to 460		
Power Specifications	Power Source *2	V(Hz)		Three-phase 200 to 220 ±10% (50/60)				
	Power Consumption *1	kW		13.5	18.1	23.9	37.2	
	Electric Current *1	A		41.4	56.3	73.6	114.9	
	Power Capacity *3	kVA		17.7	22.0	34.1	43.3	
	Breaker Capacity *6	A		75	100	125	175	
Operation Control Method		Compressor speed control						
Equipment Details	Compressor	Construction	Fully sealed scroll type (inverter driven)					
		Output	kW		7.46	11.19	7.46×2	11.19×2
	Condenser		Fin and tube forced air cooling					
	Heat Exchanger	Construction	Plate type heat exchanger					
		Material	SUS316 (Brazing: Cu)					
	Discharge Pump	Construction	Multistage centrifugal immersion type					
		Output	kW		4.0 (Inverter driven)	4.0 (Inverter driven)	4.0×2 (Inverter driven)	
	Fan Motor	Output	kW		0.4×2 (Inverter driven)		0.86×2 (Inverter driven)	
	Water Tank Capacity		L		Approx. 100		Approx. 250	
	Refrigerant		R410A					
Charged Amount		kg		5.2	7.0	6.7×2		
External Dimensions (H×D×W)		mm		1700×854×1380		1800×854×1610		
Unit Mass (dry weight)		kg		415	460	1050	1065	
Operating Noise Level (50/60 Hz) *5		dB		69	68	63	64	

*1. Operating conditions: Chilled water temp : 20 °C, Ambient temp : 32 °C. Cooling capacity is at least 95% of listed figures. *2. Source voltage phase unbalance should be less than ±3%. *3. The figure noted is when operating at the highest capacity in the normal operating range. *4. Continuous current load fluctuation within ±10%, and with stable ambient temp and power supply, etc. Does not include starting times or when the cooling load is too small, in which case the compressor may cycle on and off. *5. Operating noise levels are from a position of 1 m in front of the unit and at a height of 1 m. *6. Unit comes with a built-in multi-purpose overload and short circuit protection breaker. *7. For liquid temperature settings of 0 to 3 °C, use a 30 to 40% solution of industrial-use ethylene glycol. *8. At time of startup only. Will differ depending on ambient temperature.

Note 1: The recommended liquid (chilled water) that can be used is either clean water or a 30 to 40% ethylene glycol solution. Note that there will be a 10% reduction in cooling capacity if using a 30 to 40% ethylene glycol solution. Alternatively, if deionized water is to be used, it should have an electrical conductivity of at least 1 μS/cm.

Note 2: Heat output from the unit (in kW) is approx. 1.3 times that of the cooling capacity.

Cooling Capacity

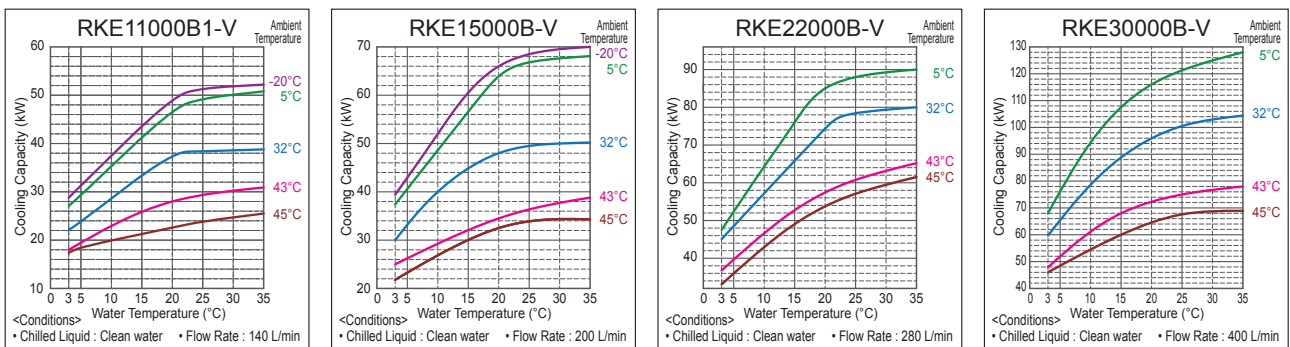

Chilled Water Flow Chart

* The illustration shows the actual measured flow rate value when the bypass valve is closed.

* Flow rate changes based on inverter frequency

* The shaded area indicates the range possible for the adjusted frequency value.

* If additives are used, the flow rate characteristics will change due to factors such as the additive used, the concentration, fluid temp, etc.

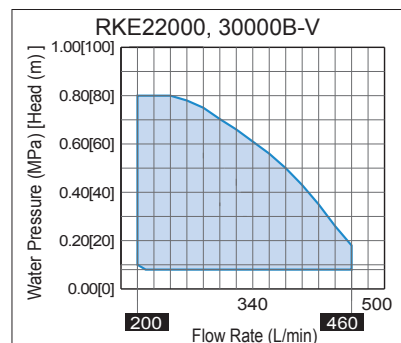
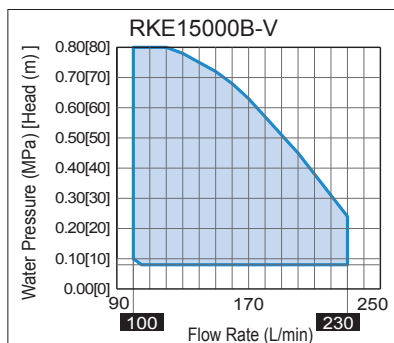
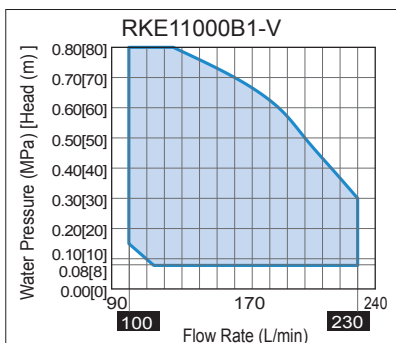

External Dimensions (Units: mm)

RKE11000B1-V, 15000B-V

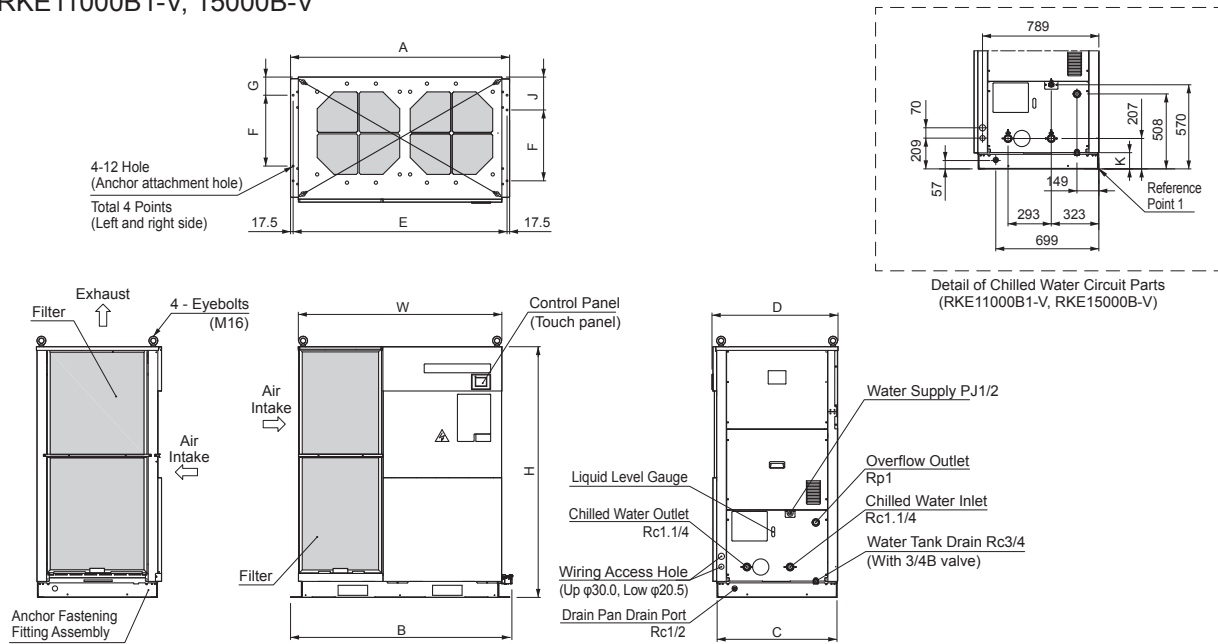

External Dimension Table (units : mm)

Model	Size	W	H	A	B	C	D	E	F	G	J	K
RKE11000B1-V		1380	1700	1485	1500	812	854	1450	480	123	223	110
RKE15000B-V		1610	1800	1715	1730	812	854	1680	480	123	223	110

RKE-B Series

RKE22000, 30000B-V

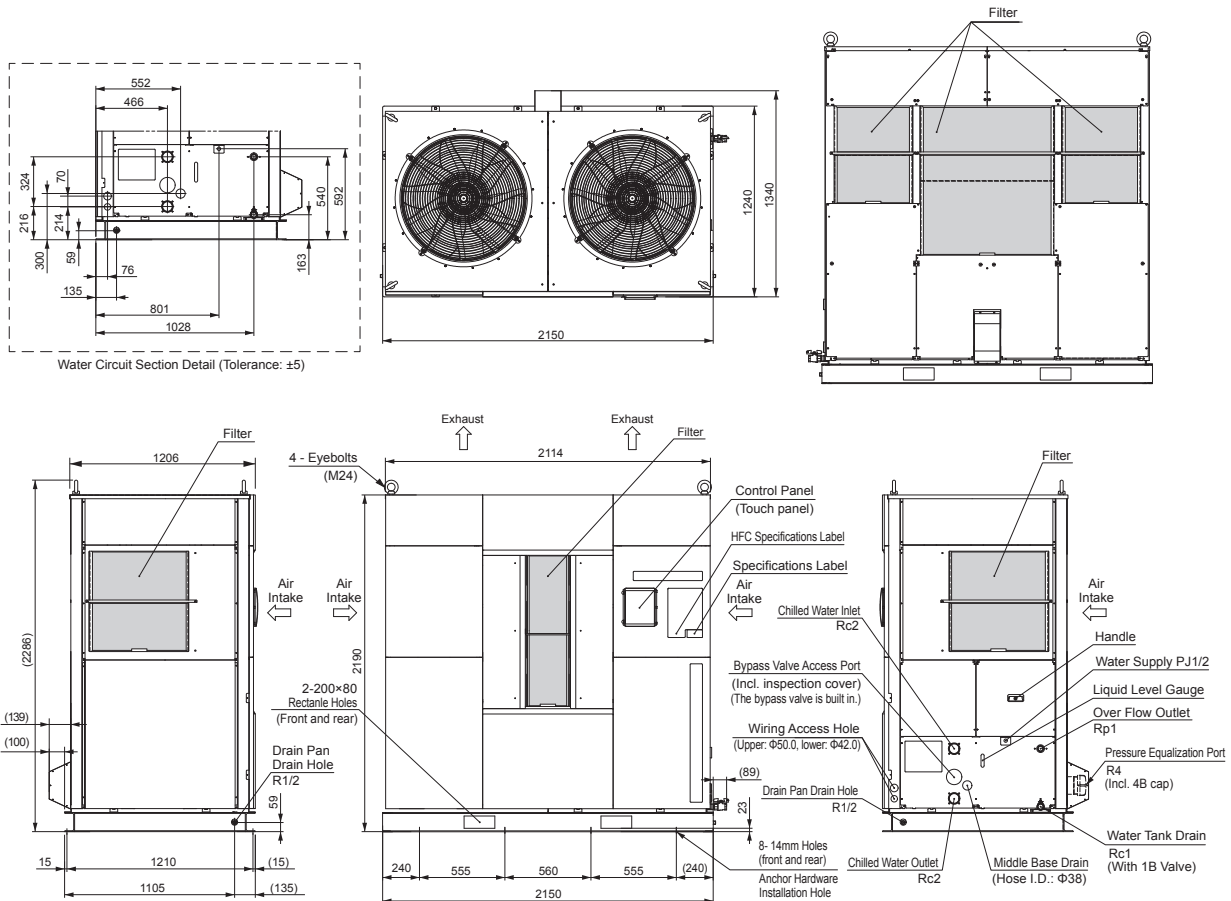

Water Circuit Section Detail (Tolerance: ±5)

Specifications

Model		RKE11000B1-VW	RKE15000B-VW	
Performance Specifications	Cooling Capacity *1	kW	43.0	48.0
	Legal Refrigeration Tonnage		4.17	4.95
	Heating Capacity *8	kW	9.1	10.0
	Operable Ambient Temperature Range	°C	-20 to 45	-20 to 45 (-20~50 with an accessory, sold separately)
	Cooling Water Temperature Range	°C	5 to 45	
	Operable Liquid Temperature Range	°C	3 to 35 (w/ brine: 0 to 35) *7	
	Control Precision *4		±0.1 °C (Energy saving mode: ±2.0 °C)	
Power Specifications	Operating Flow Rate	L/min	100 to 230	
	Power Source *2	V(Hz)	Three-phase 200 ±10% (50) / 200 to 220 ±10% (60)	
	Power Consumption *1	kW	11.7	15.3
	Electric Current *1	A	36.3	48.2
	Power Capacity *3	kVA	17.2	19.5
Breaker Capacity *6	A	75		
Operation Control Method		Compressor speed control		
Equipment Details	Compressor	Construction	Fully sealed scroll type (inverter driven)	
		Output	kW	7.46
	Condenser		Double pipe water cooling	
	Heat Exchanger	Construction	Plate type heat exchanger	
		Material	SUS316 (Brazing: Cu)	
	Discharge Pump	Construction	Multistage centrifugal immersion type	
		Output	kW	4.0 (Inverter driven)
	Water Tank Capacity		L	Approx. 100
Refrigerant			R410A	
Charged Amount		kg	3.6	
External Dimensions (H×D×W)		mm	1410×854×1380	
Unit Mass (dry weight)		kg	405	405
Operating Noise Level (50/60 Hz) *5		dB	61	59

*1. Operating conditions: Chilled water temp.: 20 °C, Cooling water temp.: 32 °C, Ambient temp.: 32 °C. Cooling capacity is at least 95% of listed figures. *2. Source voltage phase unbalance should be less than ±3%. *3. The figure noted is when operating at the highest capacity in the normal operating range. *4. Continuous current load fluctuation within ±10%, and with stable ambient temp. and power supply, etc. Does not include starting times or when the cooling load is too small, in which case the compressor may cycle on and off. *5. Operating noise levels are from a position of 1 m in front of the unit and at a height of 1 m. *6. Unit comes with a built-in multi-purpose overload and short circuit protection breaker. *7. For liquid temperature settings of 0 to 3 °C, use a 30 to 40% solution of industrial-use ethylene glycol. *8. At time of startup only. Will differ depending on ambient temperature and cooling water temperature. Note 1: The recommended liquid (chilled water) that can be used is either clean water or a 30 to 40% ethylene glycol solution. Note that there will be a 10% reduction in cooling capacity if using a 30 to 40% ethylene glycol solution. Alternatively, if deionized water is to be used, it should have an electrical conductivity of at least 1 µS/cm.

Cooling Capacity Diagram: Air Cooled Model Cooling Power Comparison Diagram

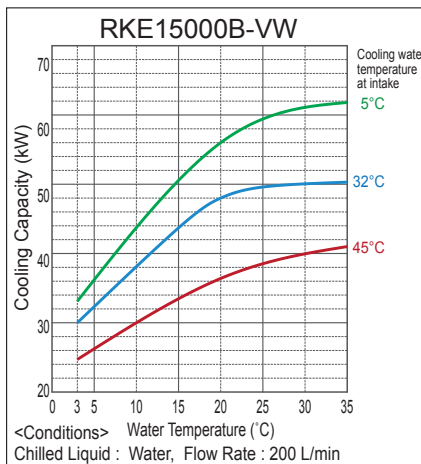
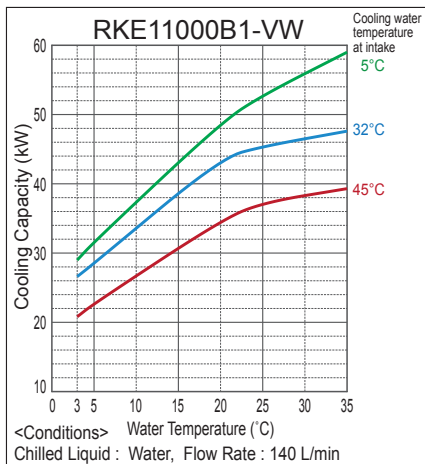

Cooling Water Flow Rate (For the water cooled condenser)

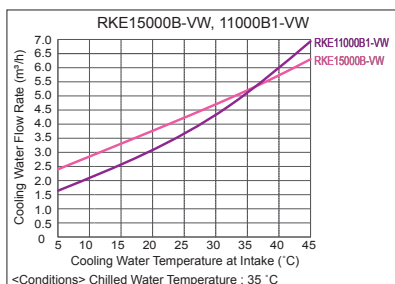

* Ensure that the cooling water flow rate is suitable for the cooling water temperature.

Chilled Water Flow Chart

- * The illustration shows the actual measured flow rate value when the bypass valve is closed.
- * Flow rate changes based on inverter frequency.
- * The shaded area indicates the range possible for the adjusted frequency value.
- * If additives are used, the flow rate characteristics will change due to factors such as the additive used, the concentration, fluid temp, etc.

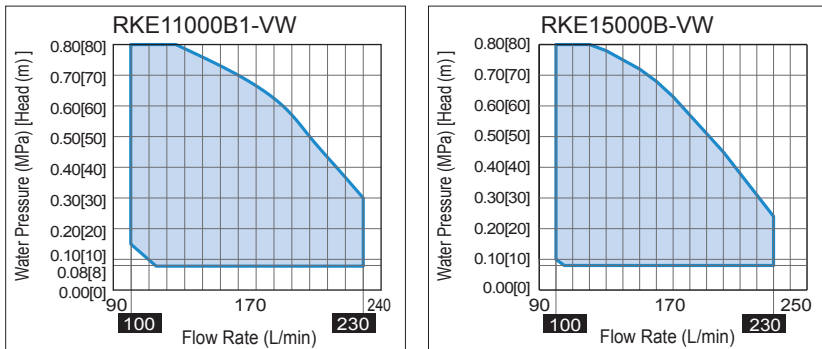

External Dimensions (Units: mm)

RKE11000B1-VW, 15000B-VW

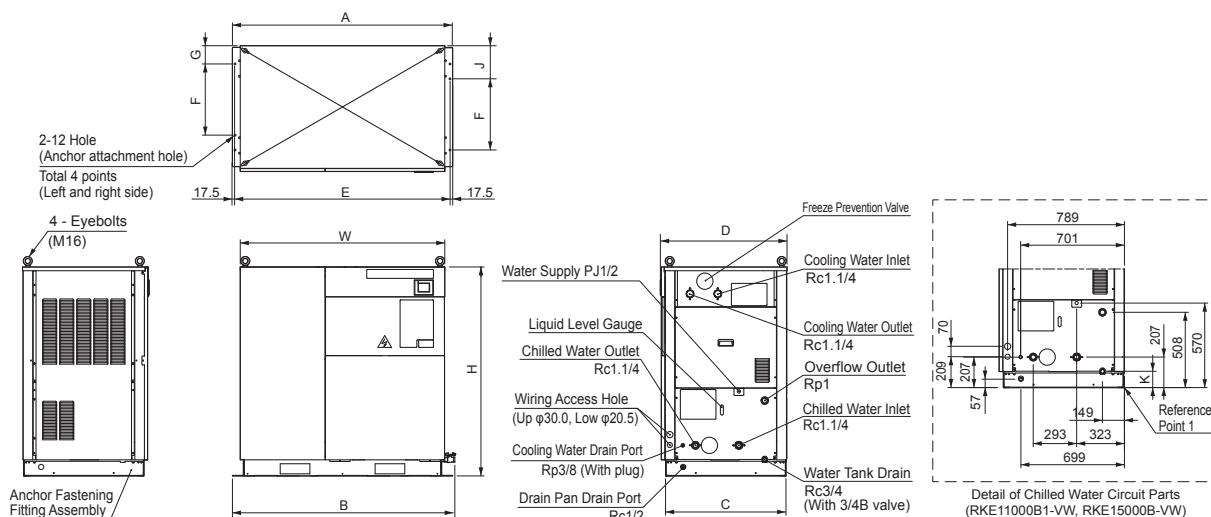

External Dimension Table (units : mm)

Model	Size	W	H	A	B	C	D	E	F	G	J	K
RKE11000B1-VW		1380	1410	1485	1500	812	854	1450	480	123	223	110
RKE15000B-VW		1380	1410	1485	1500	812	854	1450	480	123	223	110

Equipment (Standard / Optional) List Air Cooled

RKE-B Series

		Function
		Item Detail
Operating Environment	Copper-free wetted parts	-
	Operable Ambient Temp. Range	High-temperature range specification. Up to 50 °C (air cooled and water cooled). Requires assembly of the distribution panel high-temperature configuration set.
	Freeze Prevention Mode	This function operates the discharge pump in order to prevent water temperature drops and freezing during winter months when operation is stopped. When enabled, the discharge pump will operate when the water temperature falls to 3 °C or below.
	Warming-up Mode	This function will automatically operate the discharge pump when the product is otherwise not operating when the ambient temperature is low, for example during winter months, in order to prevent the water temperature from dropping too much and in order to help maintain the set water temperature.
	Low Noise Mode *1	This function will limit the upper speed of the fan, thus reducing fan ventilation noise.
	Outside Installation	IPX4 Equiv. Rating
	Snow Protection Hood	Prevents falling snow from accumulating on the fan vent.
	Wind Protection Panel Set	As a guideline, install when the wind speed is 8 m/s or higher.
	Vibration Isolation Platform	Reduces transmission of vibration from the chiller.
Chilled Water Circuit	Discharge Pump Specs.	Configuration with built-in high flow rate pump and built-in high pressure pump is possible.
	Pressure Relief Valve	Can provide equipment-side pressure protection.
	Chilled Water Circuit Water Filter	Water filter C assembly
	Water Deionizing Equipment for Chilled Water Circulation Circuit	Deionizing Unit E Assembly
	Water Deionizing Equipment for Chilled Water Supply and Supply Circuits	Water Deionizing Equipment for supply water.
Power Supply and Control Specs	Primary Power Supply Voltage	Three-phase 200 to 220 V (50/60 Hz) Three-phase 230 V (50 Hz), 380 V / 400 V / 440 V (50/60 Hz)
	Overload Safety Devices	The product comes with a built in multipurpose overload and short circuit protection breaker.
	Power Outage Recovery Operation Settings	Can choose the recovery pattern after power outage. (Manual recovery / Automatic recovery / Remote operation priority)
	Audible Alarm Enable/Disable	Audible alarm can be enabled or disabled for each audible alarm or warning.
	Communications	USB and RS-422A/485 communications allow operation and setting changes from a remote location. To connect multiple units, set the communication device address number to any number between 0 and 31.
	Remote Control (Wired)	By connecting the remote control, the product can be operated from a remote location, and various settings can be changed as if using the touch panel.
	Central Chiller Controller	By connecting the Central Chiller Controller to multiple units, each of the units can be operated, and their settings changed. (Registration of up to 4 groups with 4 units per group is possible.)
	Remote Control Terminals	Remote Operation (No-voltage contacts)
	Signal Output Terminals	Operation Signal Alarm Signal Temperature warning signal
Others	External Surface Coating Thickness	Polyester resin, min. 30 μm Polyester resin, min. 45 μm (Salt-corrosion prevention spec.)
	Color Designation * Specify the desired color using the JPMA number or Munsell number (and include a color sample).	- -
	Packaging for Export	Basic plywood packaging
	Heating Functionality	Used to raise the temperature during product startup. (Built-in 200 VAC electric heater.) * ON/OFF control to the set liquid temperature minus 2 ±0.5 °C.
	Inspection Manual	Japanese English
	Test Results Chart	Japanese English
	Witness Inspection	-

*1: The maximum decrease in cooling capacity is 20%.

Comments	Model			
	11000B1-V	15000B-V	22000B-V	30000B-V
Copper alloy is used for wetted parts on standard units.	Special Specification			
Be careful of freezing at low temperatures as well as abnormal temperature rises due to placement in direct sunlight.	-	Optional Accessories (Sold separately)	-	-
Can be enabled or disabled via the intelligent touch panel. * Cannot be used at the same time as the warming-up mode.	Standard			
Can be enabled or disabled via the intelligent touch panel. * Cannot be used at the same time as the freeze prevention mode.	Standard			
Can change between "normal" and "low noise" modes from the intelligent touch panel.	Standard			
Installation in direct sunlight, strong wind (8 m/sec or higher), contact with falling snow, or freezing conditions requires further measures.	Standard			
-	Optional Accessories (Sold separately)			
-	Optional Accessories (Sold separately)			
The vibration isolation platform should be installed on a level full-width foundation with no uneven surfaces. If there is a difference in height of more than 5 mm between the four corners of the vibration isolation platform when the chiller is installed, then adjustment will be required.	Optional Accessories (Sold separately)			
Please specify the required flowrate and pressure.	Special Specification			
Please specify the relief pressure.	Special Specification			
Filtration Rating: 100 µm (5 µm, 10 µm, 20 µm, and 50µm are available as special specification products.) *Operate at or below 0.5 MPa.	Optional Accessories (Sold separately)		Special Specification	
Water Quality: 10 µS/cm or lower	Optional Accessories (Sold separately)			
Including electrical conductivity gauge and flow regulating valve.	Optional Accessories (Sold separately)			
-	Standard			
The transformer can be installed separately. The maximum ambient temperature for the transformer is 45 °C.	Manufacturer Option		Special Specification	
-	Standard (Current sensitivity: 100 mA)			
Action to be taken after recovery can be enabled or disabled via the intelligent touch panel.	Standard			
The audible alarm can be enabled or disabled via the intelligent touch panel.	Standard			
-	Standard			
Max. wiring length: 20 m	Optional Accessories (Sold separately)			
Max. wiring length: 50 m	Optional Accessories (Sold separately)			
Max. wiring length: 100 m	Optional Accessories (Sold separately)			
The Central Chiller Controller does not include communication cables. See page 59 for details.	-		Optional Accessories (Sold separately)	
Max. wiring length: 20 m (w/o cable)	Standard			
No-voltage contacts	Standard			
No-voltage contacts	Standard			
No-voltage contacts	Standard			
-	Standard			
External screws are stainless steel. Condenser and refrigerant piping are treated with a corrosion-resistant coating. Acrylic resin coating, at least 15 µm thick	Manufacturer Option		Special Specification	
For other paint/coatings	Special Specification			
Please consult your dealer regarding JIS standard packaging.	Manufacturer Option		Special Specification	
Heating output: 5 kW	Manufacturer Option		Special Specification	
-	Manufacturer Option		Special Specification	
-	Manufacturer Option		Special Specification	
-	Manufacturer Option		Special Specification	
-	Manufacturer Option		Special Specification	
-	Manufacturer Option		Special Specification	

Equipment (Standard / Optional) List Water Cooled

RKE-B Series

		Function
		Item Detail
Operating Environment	Copper-free wetted parts	-
	Operable Ambient Temp. Range	High-temperature range specification. Up to 50 °C (air cooled and water cooled). Requires assembly of the distribution panel high-temperature configuration set.
	Freeze Prevention Mode	This function operates the discharge pump in order to prevent water temperature drops and freezing during winter months when operation is stopped. When enabled, the discharge pump will operate when the water temperature falls to 3 °C or below.
	Warming-up Mode	This function will automatically operate the discharge pump when the product is otherwise not operating when the ambient temperature is low, for example during winter months, in order to prevent the water temperature from dropping too much and in order to help maintain the set water temperature.
	Outside Installation	IPX4 Equiv. Rating
	Cleanroom (Leakage Alarm Spec.)	In addition to the standard specification, leakage sensors, pressure resistant piping, refrigerant piping insulation, and water piping insulation are added.
	Water Leakage Detection	Leak detector built in.
	Vibration Isolation Platform	Reduces transmission of vibration from the chiller.
Chilled Water Circuit	Discharge Pump Specs.	Configuration with built-in high flow rate pump and built-in high pressure pump is possible.
	Pressure Relief Valve	Can provide equipment-side pressure protection.
	Chilled Water Circuit Water Filter	Water filter C assembly
	Water Deionizing Equipment for Chilled Water Circulation Circuit	Deionizing Unit E Assembly
	Water Deionizing Equipment for Chilled Water Supply and Supply Circuits	Water Deionizing Equipment for supply water.
Power Supply and Control Specs	Primary Power Supply Voltage	Three-phase 200 to 220 V (50/60 Hz)
		Three-phase 230 V (50 Hz), 380 V / 400 V / 440 V (50/60 Hz)
	Overload Safety Devices	The product comes with a built in multipurpose overload and short circuit protection breaker.
	Audible Alarm Enable/Disable	Audible alarm can be enabled or disabled for each audible alarm or warning.
	Communications	USB and RS-422A/485 communications allow operation and setting changes from a remote location. To connect multiple units, set the communication device address number to any number between 0 and 31.
	Remote Control (Wired)	By connecting the remote control, the product can be operated from a remote location, and various settings can be changed as if using the touch panel.
	Remote Control Terminals	Remote Operation (No-voltage contacts)
	Signal Output Terminals	Operation Signal
Alarm Signal		
Temperature warning signal		
Others	External Surface Coating Thickness	Polyester resin, min. 30 μm
		Polyester resin, min. 45 μm (Salt-corrosion prevention spec.)
	Color Designation * Specify the desired color using the JPMA number or Munsell number (and include a color sample).	- -
	Packaging for Export	Basic plywood packaging
	Heating Functionality	Used to raise the temperature during product startup. (Built-in 200 VAC electric heater.) * ON/OFF control to the set liquid temperature minus 2 ±0.5 °C.
	Inspection Manual	Japanese
		English
	Test Results Chart	Japanese
English		
Witness Inspection	-	

Comments	Model	
	11000B1-VW	15000B-VW
Copper alloy is used for wetted parts on standard units.	Special Specification	
Be careful of freezing at low temperatures as well as abnormal temperature rises due to placement in direct sunlight.	-	Optional Accessories (Sold separately)
Can be enabled or disabled via the intelligent touch panel.	Standard	
* Cannot be used at the same time as the warming-up mode.	Standard	
Installation in direct sunlight, strong wind (8 m/sec or higher), contact with falling snow, or freezing conditions requires further measures.	Standard	
Particulate is not taken into account.	Manufacturer Option	
-	Manufacturer Option	
The vibration isolation platform should be installed on a level full-width foundation with no uneven surfaces. If there is a difference in height of more than 5 mm between the four corners of the vibration isolation platform when the chiller is installed, then adjustment will be required.	Optional Accessories (Sold separately)	
Please specify the required flowrate and pressure.	Special Specification	
Please specify the relief pressure.	Manufacturer Option	
Filtration Rating: 100 µm (5 µm, 10 µm, 20 µm, and 50µm are available as special specification products.) *Operate at or below 0.5 MPa.	Optional Accessories (Sold separately)	
Water Quality: 10 µS/cm or lower	Optional Accessories (Sold separately)	
Including electrical conductivity gauge and flow regulating valve.	Optional Accessories (Sold separately)	
-	Standard	
The transformer can be installed separately. The maximum ambient temperature for the transformer is 45 °C.	Manufacturer Option	
-	Standard	
The audible alarm can be enabled or disabled via the intelligent touch panel.	Standard	
-	Standard	
Max. wiring length: 20 m	Optional Accessories (Sold separately)	
Max. wiring length: 50 m	Optional Accessories (Sold separately)	
Max. wiring length: 100 m	Optional Accessories (Sold separately)	
Max. wiring length: 20 m (w/o cable)	Standard	
No-voltage contacts	Standard	
No-voltage contacts	Standard	
No-voltage contacts	Standard	
-	Standard	
External screws are stainless steel. Condenser and refrigerant piping are treated with a corrosion-resistant coating.	Manufacturer Option	
Acrylic resin coating, at least 15 µm thick	Special Specification	
For other paint/coatings		
Please consult your dealer regarding JIS standard packaging.	Manufacturer Option	
Heating output: 5 kW	Manufacturer Option	
-	Manufacturer Option	
-	Manufacturer Option	
-	Manufacturer Option	
-	Manufacturer Option	
-	Manufacturer Option	

Manufacturer Options Table

RKE-B Series Optional Item Numbering Outline Air Cooled

The manufacturer optional item numbers are 6 digits. Please refer to the Optional Item Number Table below and use these numbers when making dealer requests. *These options are not applicable to RKE22000 and 30000B-V models. Please consult your dealer for details.

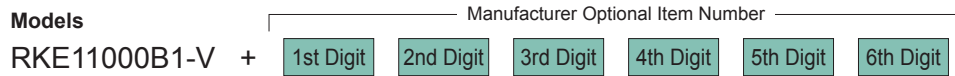

1st Digit	2nd Digit	3rd Digit	4th Digit	5th Digit	6th Digit
0: Standard	0: Standard	0: Standard	0: Standard	0: Standard	0: Standard
1: Different voltage (380/400/440 V)			1: Incl. relief valve	1: English specification	1: No water tank
		2: Custom color		2: Test results chart (shipped separately)	2: Anchor bolts (SS)
		3: Salt-corrosion prevention spec.		3: Inspection manual (shipped separately)	3: Anchor bolts (SUS)
				4: Witness Inspection	
5: Packaging for export (plywood siding)				5: English specification + Test results chart (shipped separately)	
				6: English specification + Inspection manual (shipped separately)	
7: Incl. heater (5 kW)				7: English specification + Witness Inspection	
				8: Test results chart (shipped separately) + Inspection manual (shipped separately)	
				9: Test results chart (shipped separately) + Witness Inspection	
				A: Inspection manual (shipped separately) + Witness Inspection	
				B: English specification + Test results chart (shipped separately) + Inspection manual (shipped separately)	
				C: English specification + Test results chart (shipped separately) + Witness Inspection	
				D: Test results chart (shipped separately) + Inspection manual (shipped separately) + Witness Inspection	
				E: English specification + Test results chart (shipped separately) + Inspection manual (shipped separately) + Witness Inspection	

RKE-B Series

Manufacturer Options Details Air Cooled

Item	Description
Different voltage (380/400/440 V)	o The transformer can be installed separately.
Packaging for export (plywood siding)	o Basic plywood packaging *Please consult your dealer regarding JIS standard packaging.
Incl. heater	o Used to raise the temperature during startup. (Built-in 200 VAC heater) *ON-OFF control at the liquid temperature setting - 2 °C ±0.5 °C.
Custom color	o Please contact your dealer if a designated coating is required. o A color sample will be required for custom colors using Munsell numbers.
Salt-corrosion prevention spec	o Coating film of 45 μm or thicker used on exterior cabinet surfaces, lower base, and drain pan. o Upper cabinet panel fan mounting bolts: SUS304 o External screws: SUS304 o Condenser and refrigerant piping: Corrosion-resistant paint o Control board and compressor inverter circuit board: Processed with moisture-proof insulation coating. *Differs from the salt damage standards set by the Japan Refrigeration and Air Conditioning Industry Association "JRA".
Incl. relief valve	o Set to the maximum operating pressure (0.8 MPa).
English specification	o Machine plates and English operating manual
Test results chart	o Documentation produced by ORION.
Inspection manual	o Documentation produced by ORION.

RKE-B Series Optional Item Numbering Outline Water Cooled

The manufacturer optional item numbers are 6 digits. Please refer to the Optional Item Number Table below and use these numbers when making dealer requests.

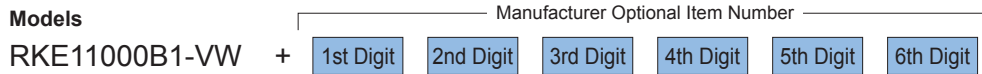

1st Digit	2nd Digit	3rd Digit	4th Digit	5th Digit	6th Digit
0: Standard	0: Standard	0: Standard	0: Standard	0: Standard	0: Standard
1: Different voltage (380/400/440 V)			1: Incl. relief valve	1: English specification	1: No water tank
		2: Custom color	2: Cleanroom Spec.	2: Test results chart (shipped separately)	2: Anchor bolts (SS)
		3: Salt-corrosion prevention spec.	3: Leakage detector	3: Inspection manual (shipped separately)	3: Anchor bolts (SUS)
			4: Relief valve + Cleanroom spec.	4: Witness Inspection	
5: Packaging for export (plywood siding)			5: Relief valve + Leakage detector	5: English specification + Test results chart (shipped separately)	
				6: English specification + Inspection manual (shipped separately)	
7: Incl. heater (5 kW)				7: English specification + Witness Inspection	
				8: Test results chart (shipped separately) + Inspection manual (shipped separately)	
				9: Test results chart (shipped separately) + Witness Inspection	
				A: Inspection manual (shipped separately) + Witness Inspection	
				B: English specification + Test results chart (shipped separately) + Inspection manual (shipped separately)	
				C: English specification + Test results chart (shipped separately) + Witness Inspection	
				D: Test results chart (shipped separately) + Inspection manual (shipped separately) + Witness Inspection	
				E: English specification + Test results chart (shipped separately) + Inspection manual (shipped separately) + Witness Inspection	

Manufacturer Options Details Water Cooled

Item	Description
Different voltage (380/400/440 V)	o The transformer can be installed separately.
Packaging for export (plywood siding)	o Basic plywood packaging *Please consult your dealer regarding JIS standard packaging.
Incl. heater	o Used to raise the temperature during startup. (Built-in 200 VAC heater) *ON-OFF control at the liquid temperature setting - 2 °C ±0.5 °C.
Custom color	o Please contact your dealer if a designated coating is required. o A color sample will be required for custom colors using Munsell numbers.
Salt-corrosion prevention spec	o Coating film of 45 µm or thicker used on exterior cabinet surfaces, lower base, and drain pan. o Upper cabinet panel fan mounting bolts: SUS304 o External screws: SUS304 o Condenser and refrigerant piping: Corrosion-resistant paint o Control board and compressor inverter circuit board: Processed with moisture-proof insulation coating. *Differs from the salt damage standards set by the Japan Refrigeration and Air Conditioning Industry Association "JRA".
Incl. relief valve	o Set to the maximum operating pressure (0.8 MPa).
Cleanroom spec.	o Includes leakage detector (For indoor installations only). When a leakage alarm occurs: "E031: Standby 1 Alarm" will be displayed. Operation stop and alarm signal outputs o Chilled water piping: Insulated, wrapped with insulation tape (excluding level gauge, pump, cooling water piping, and water-cooled condenser) o Installation of insulation on low-temperature refrigerant piping. o Removed built-in rubber foam sealing. o Insulation Hose (Uses insulation tubing) *Particulate is not taken into account.
English specification	o Machine plates and English operating manual
Test results chart	o Documentation produced by ORION.
Inspection manual	o Documentation produced by ORION.

Accessory List (These items sold separately)

RKE-B Air Cooled

Item	Description
Distribution Panel High-temperature Configuration Set	High-temperature range specification. Allows for an operable ambient temperature range upper limit of 50 °C.
Snow Protection Hood	Prevents falling snow from accumulating on the fan vent.
Wind Protection Panel	Consider a wind speed of 8 m/s or higher as a guideline.
Vibration Isolation Platform	The vibration isolation platform should be installed on a level full-width foundation with no uneven surfaces. If there is a difference in height of more than 5 mm between the four corners of the vibration isolation platform when the chiller is installed, then adjustment will be required.
Water Filter "C" Assembly	Filtration Rating: 100 µm (5 µm, 10 µm, 20 µm, and 50 µm are available as special specification products.) *Operate at or below 0.5 MPa.
Deionizing unit "E" Assembly	Water Quality: 10 µS/cm or lower
Water deionizing assembly for supply water.	Including electrical conductivity gauge and flow regulating valve.
Remote Control Set with 20 m Remote Control Cable	By connecting the remote control, the product can be operated from a remote location, and various settings can be changed as if using the touch panel.
Remote Control Set with 50 m Remote Control Cable	
Remote Control Set with 100 m Remote Control Cable	
Central Chiller Controller	By connecting the Central Chiller Controller to multiple units, individual units can be operated, and their settings changed. (Registration of up to 4 groups with 4 units per group is possible.)
20 m Central Chiller Controller Communication Cable Assembly	Communication cable used to connect the Central Chiller Controller to the chillers, and also for connections between individual chillers.
50 m Central Chiller Controller Communication Cable Assembly	

RKE-B Water Cooled

Item	Description
Distribution Panel High-temperature Configuration Set	High-temperature range specification. Allows for an operable ambient temperature range upper limit of 50 °C.
Vibration Isolation Platform	The vibration isolation platform should be installed on a level full-width foundation with no uneven surfaces. If there is a difference in height of more than 5 mm between the four corners of the vibration isolation platform when the chiller is installed, then adjustment will be required.
Water Filter "C" Assembly	Filtration Rating: 100 µm (5 µm, 10 µm, 20 µm, and 50 µm are available as special specification products.) *Operate at or below 0.5 MPa.
Deionizing unit "E" Assembly	Water Quality: 10 µS/cm or lower
Water deionizing assembly for supply water.	Including electrical conductivity gauge and flow regulating valve.
Remote Control Set with 20 m Remote Control Cable	By connecting the remote control, the product can be operated from a remote location, and various settings can be changed as if using the touch panel.
Remote Control Set with 50 m Remote Control Cable	
Remote Control Set with 100 m Remote Control Cable	



Snow Protection Hood



Wind Protection Panel



Remote Control Set

11000B1-V	15000B-V	22000B-V	30000B-V
-	04107416010	-	-
03108887010	03109803010	03111091010	
03108881010	03109802010	02104017010	
0A003805010	0A004173020	0A004626010	
04100490010		-	
	04100437010		
	04100522010		
03108949010		03111017010	
03108949020		03111017020	
03108949030		03111017030	
-		RKE-CT001	
	04107977010		
	04107977020		

RKE-B Series

11000B1-VW	15000B-VW
-	04107734010
	0A003805010
	04100490010
	04100437010
	04100522010
	03108949010
	03108949020
	03108949030



Central Chiller Controller (Wired)
*Only for RKE22000 / 30000 models.



Deionizing unit "E" Assembly



Water deionizing assembly for supply water

External Dimensions with Installed Accessories

Snow Protection Hood (Units: mm)

RKE11000B1-V

1. Snow Protection Hood Assembly Part Number: 0310887010

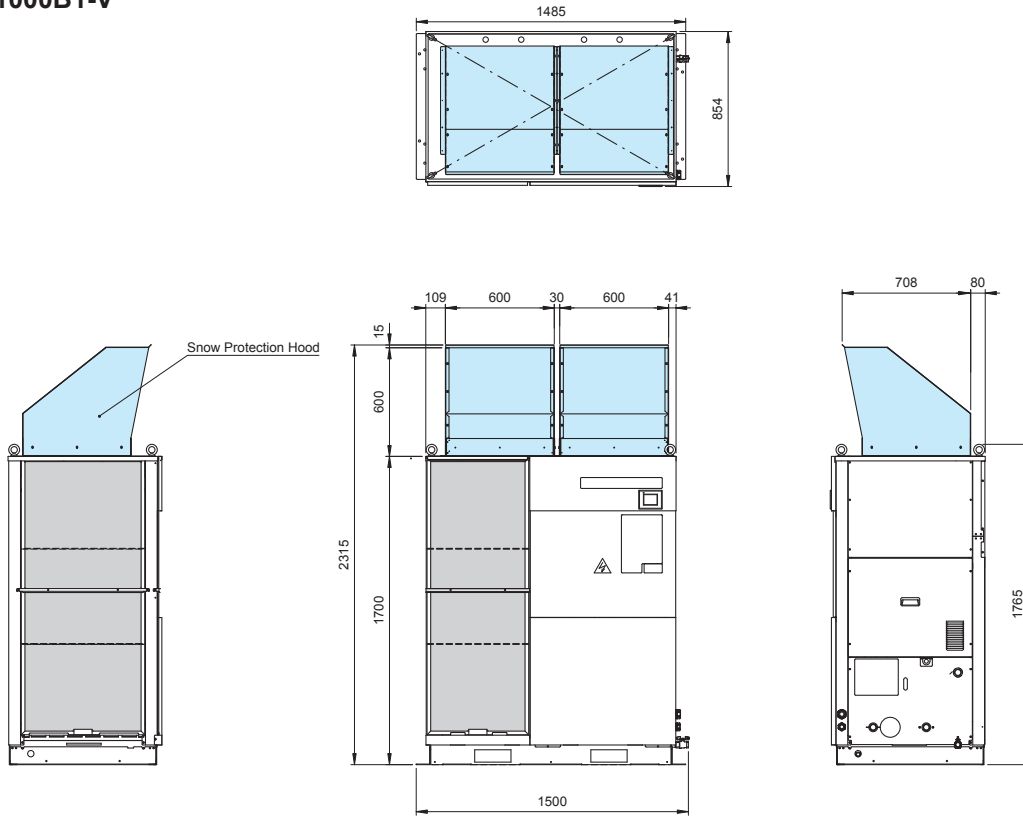

RKE-B Series

RKE15000B-V

1. Snow Protection Hood Assembly Part Number: 03109803010

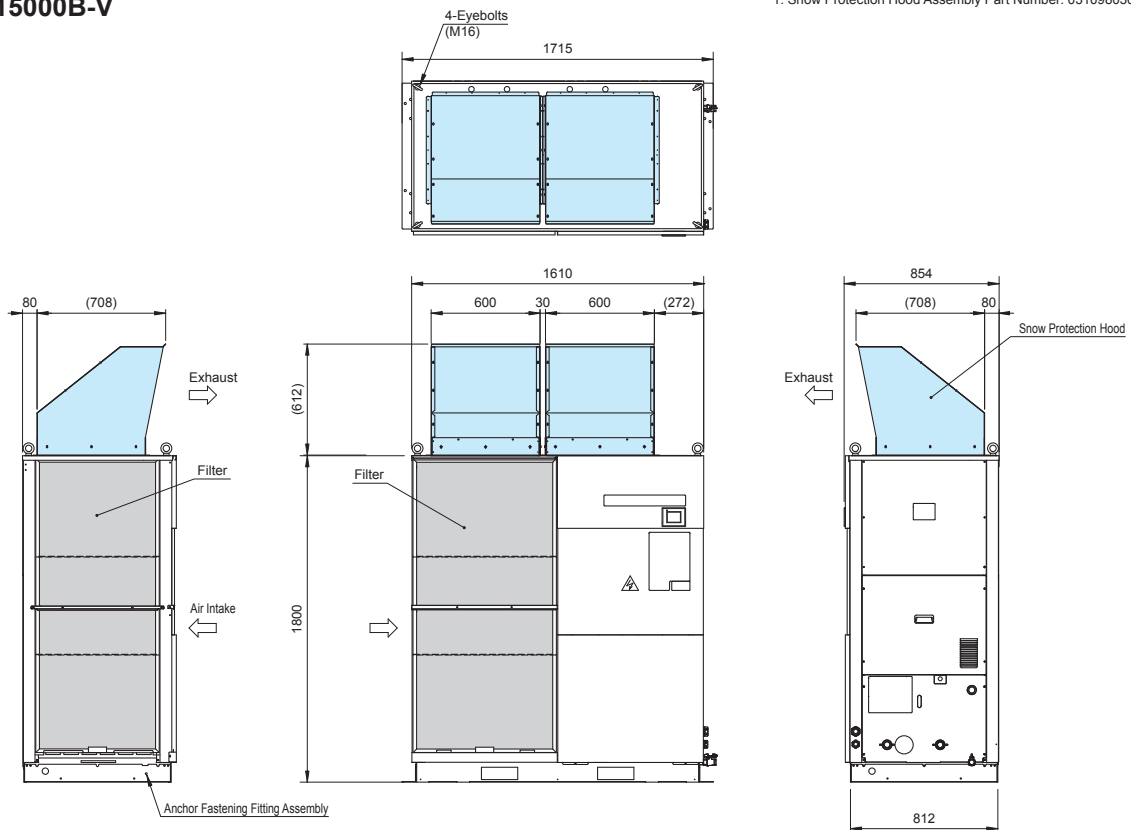

RKE22000, 30000B-V

1. Snow Protection Hood Assembly Part Number: 03111091010

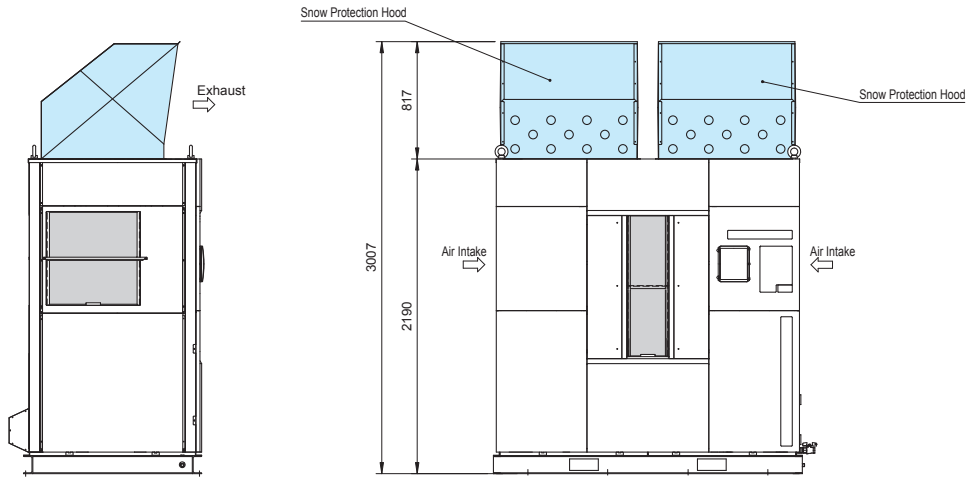
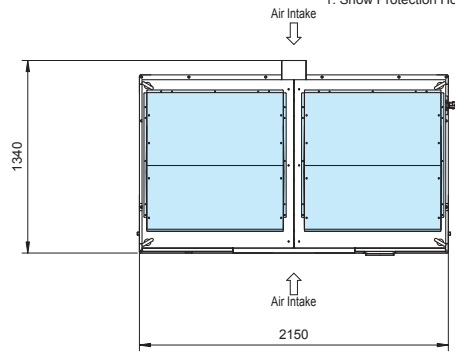

External Dimensions with Installed Accessories

Wind Protection Panel (Units: mm)

RKE11000B1-V

1. Wind Protection Panel Set Part Number: 03108881010

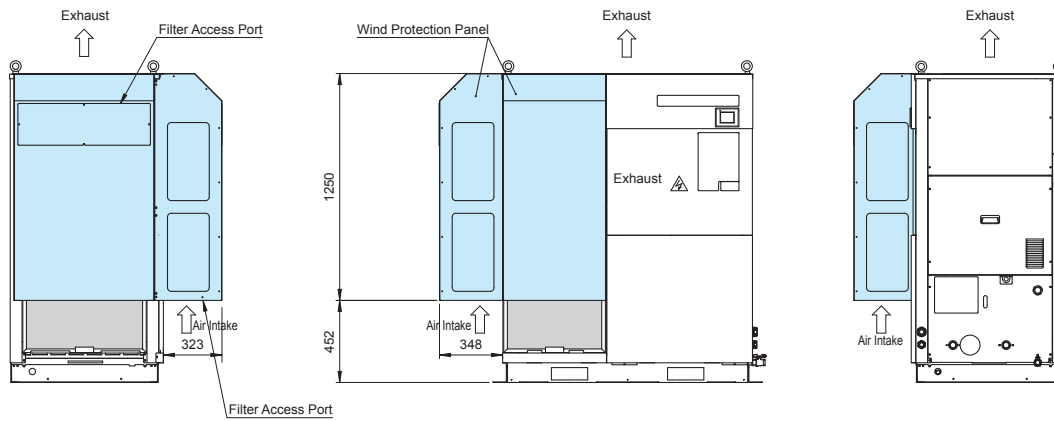
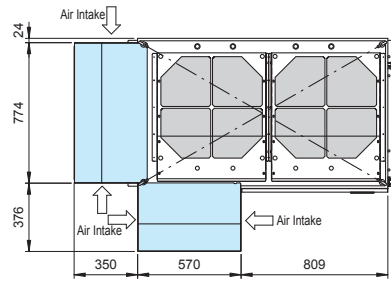

RKE-B Series

RKE15000B-V

1. Wind Protection Panel Set Part Number: 03109802010

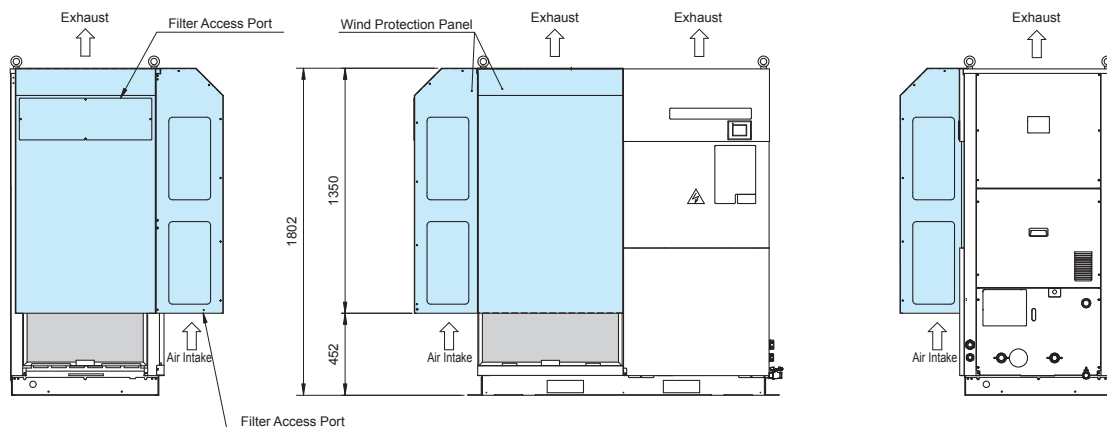
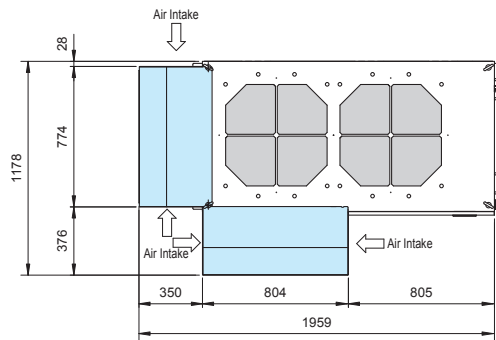

RKE22000, 30000B-V

1. Wind Protection Panel Set Part Number: 02104017010

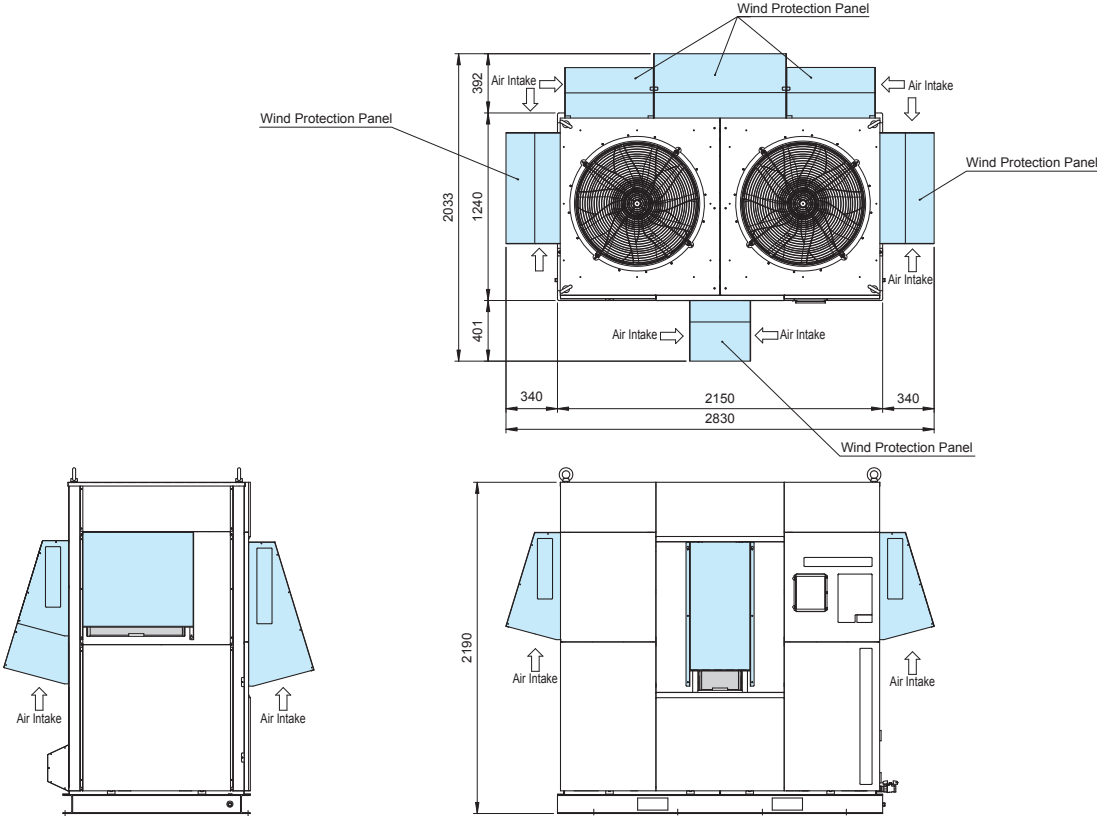

RKE-B Series

External Dimensions with Installed Accessories

Wind Protection Panel Set and Snow Protection Hood (Units: mm)

RKE11000B1-V

1. Snow Protection Hood Assembly Part Number: 03108887010
2. Wind Protection Panel Set Part Number: 03108881010

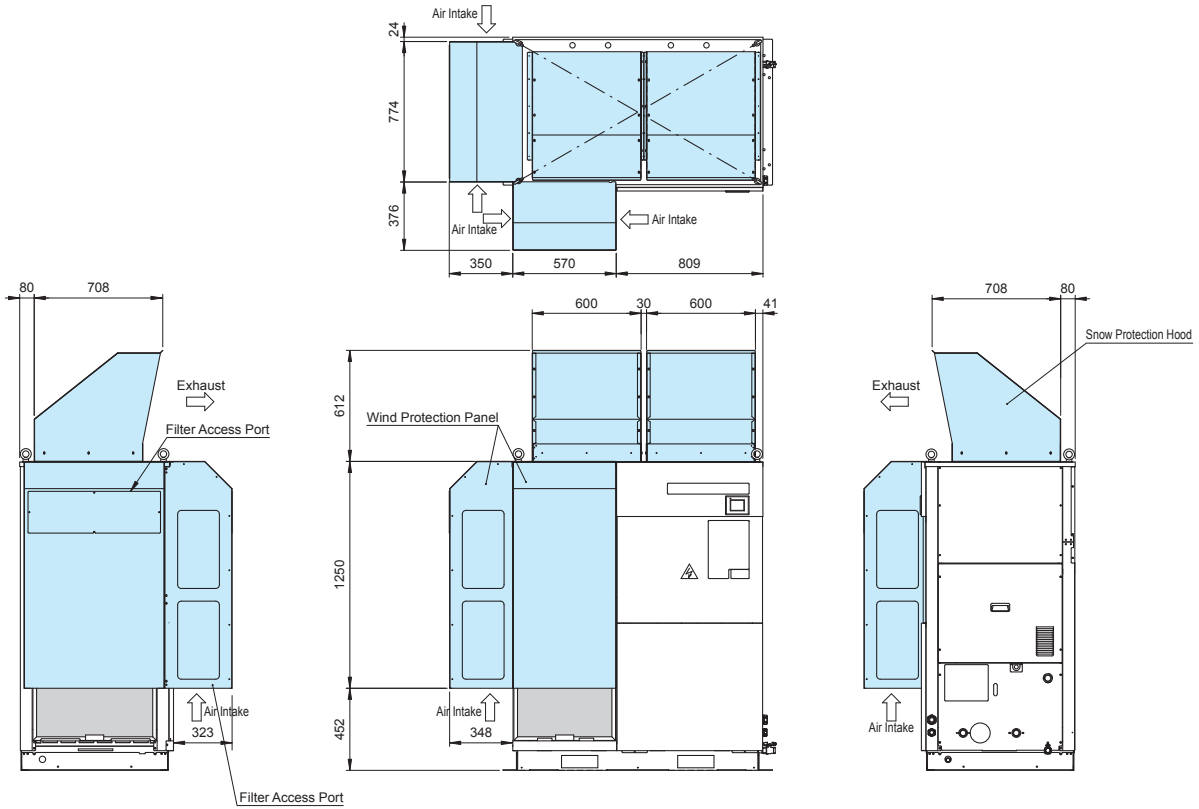

RKE15000B-V

1. Snow Protection Hood Assembly Part Number: 03109803010
2. Wind Protection Panel Set Part Number: 03109802010

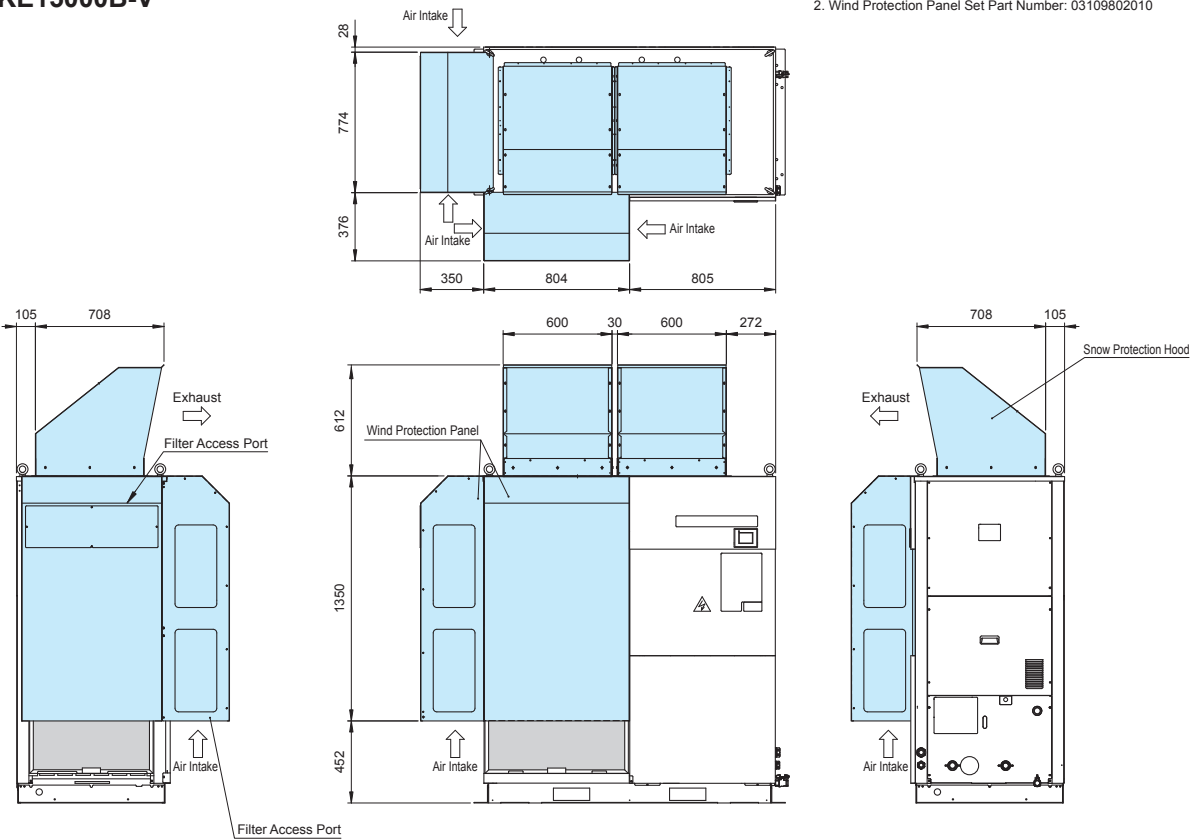

RKE22000, 30000B-V

- 1. Snow Protection Hood Assembly Part Number: 03111091010
- 2. Wind Protection Panel Set Part Number: 02104017010

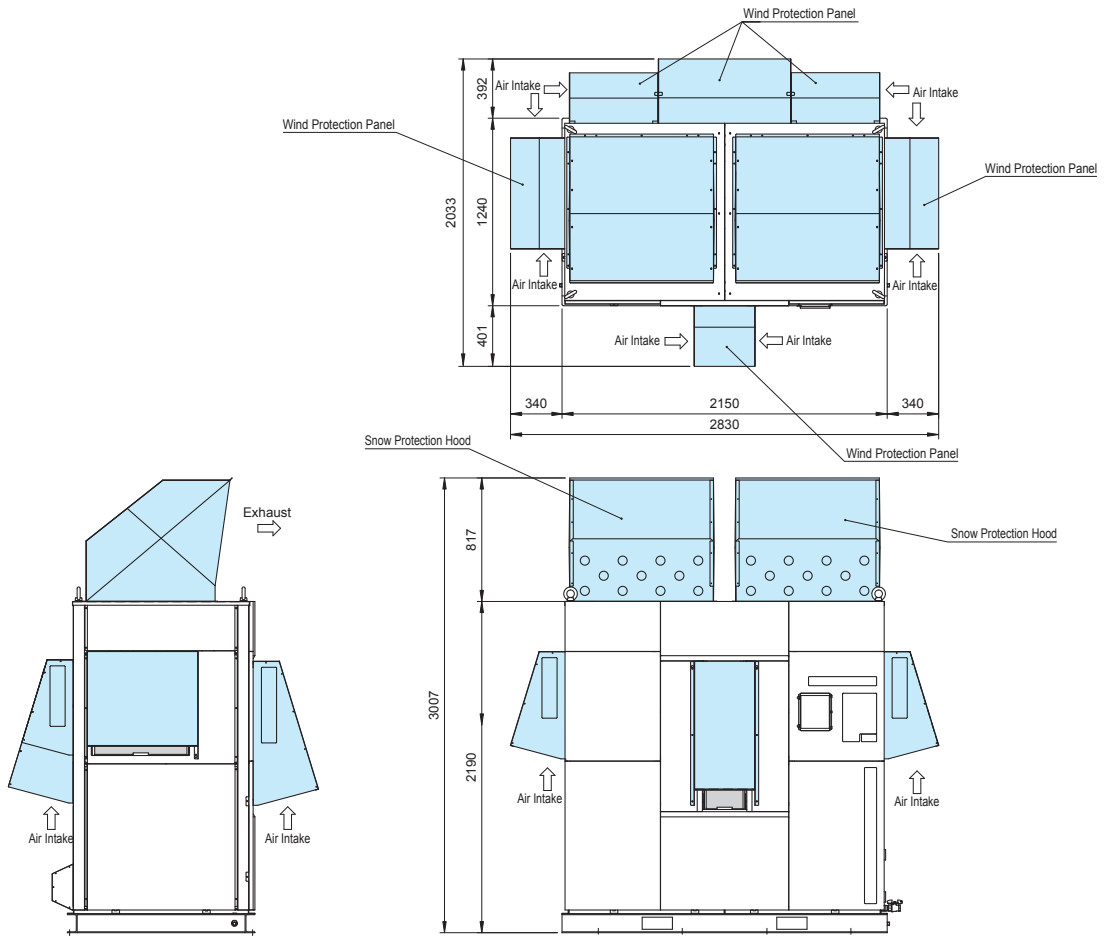

External Dimensions with Installed Accessories

Vibration Isolation Platform (Units: mm)

RKE11000B1-V

1. Vibration Isolation Platform Part Number: 0A003805010

Vibration Isolation Platform Foundation Bolt Locations
*Viewed from above.

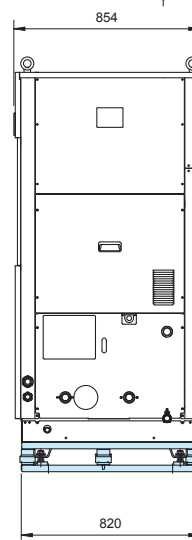
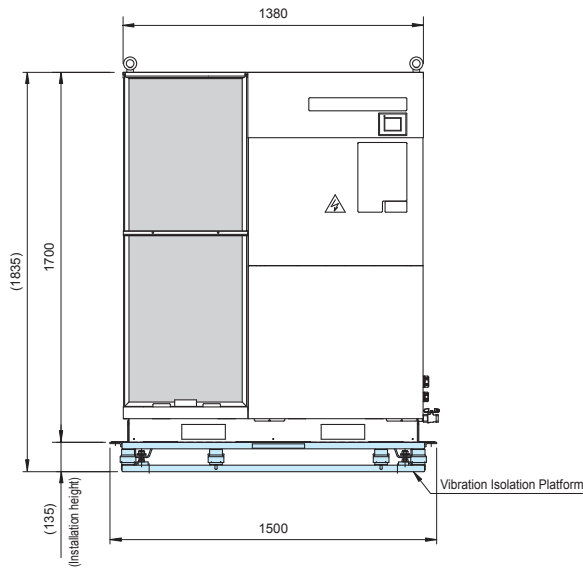
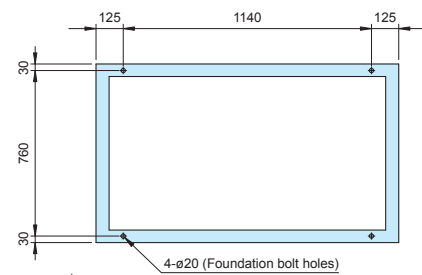

RKE-B Series

RKE15000B-V

1. Vibration Isolation Platform Part Number: 0A004173020

Vibration Isolation Platform Foundation Bolt Locations
*Viewed from above.

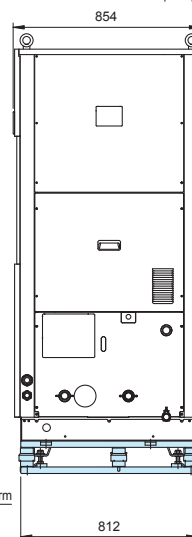
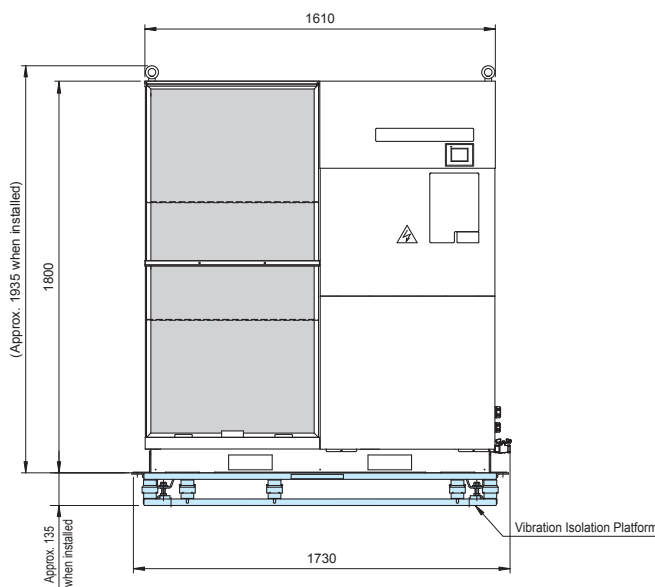
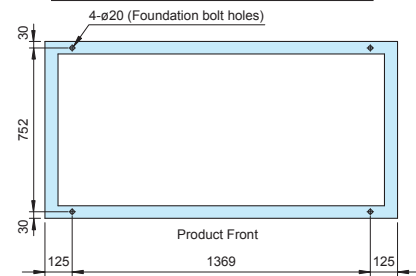

RKE22000, 3000B-V

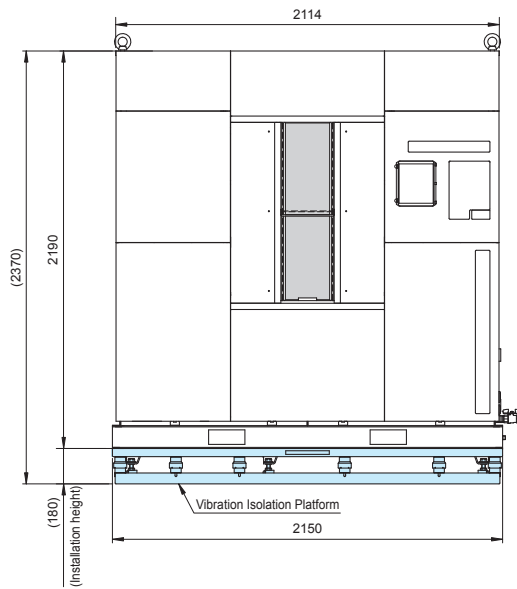

1. Vibration Isolation Platform Part Number: 0A004626010

Vibration Isolation Platform Foundation Bolt Locations
*Viewed from above.

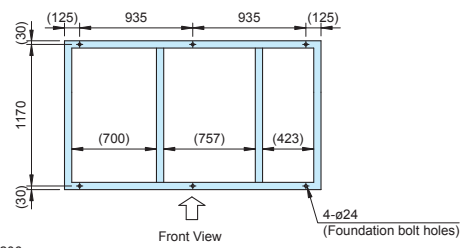

RKE11000B1-VW, 1500B-VW

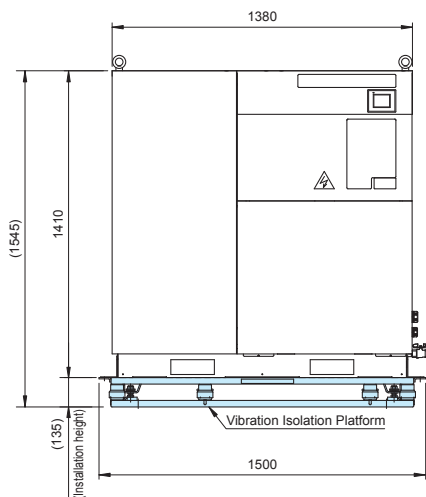

1. Vibration Isolation Platform Part Number: 0A003805010

Vibration Isolation Platform Foundation Bolt Locations
*Viewed from above.

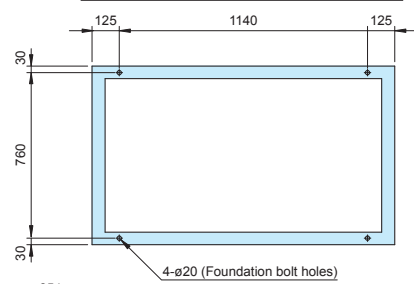

Optional Accessories (Sold separately)

Compatible with RKE22000 and 30000B-V models.

Central Chiller Controller (RKE-CT001)

When connected to individual chillers, the "Central Chiller Controller" (optional item, sold separately), can not only perform run and stop operations, but can also remotely make changes to liquid temperature settings and more on individual chillers.



Remote Operation and Monitoring of up to 16 Units Possible

(*Registration of 4 groups is possible, and up to 4 units can be registered with each group.)

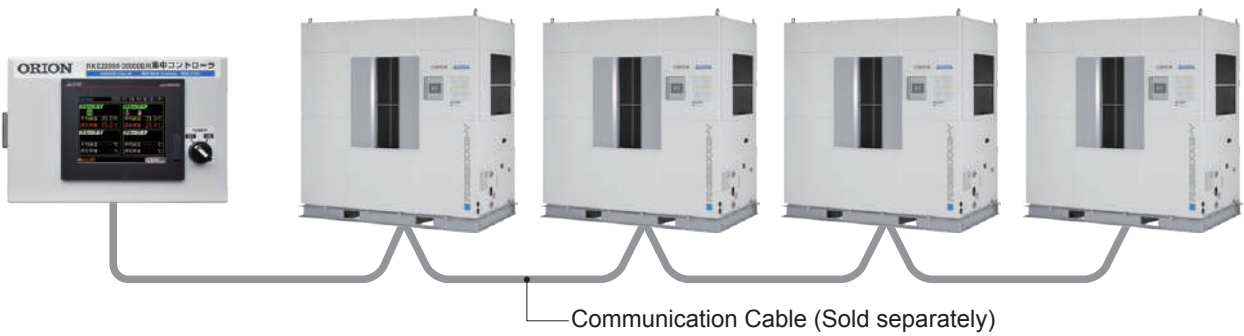

*The Central Chiller Controller does not include communication cables.

RKE-B Series

Intelligent Touch Panel makes for Easy Setting Changes and Easy Inspection

The touch panel display allows for intuitive operation and operation-confirmation, including easy changes to various settings and monitoring of operating conditions.

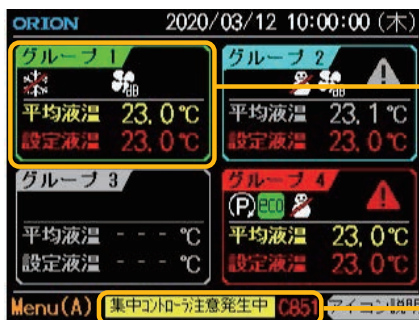

Home Screen

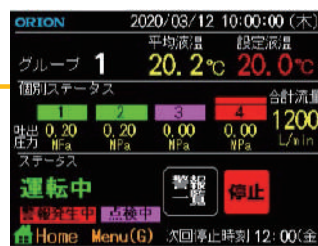

Group Details Screen



Alarm Table Screen

Central Chiller Controller Basic Functions Table

Functions possible on every unit in a group simultaneously	<ul style="list-style-type: none"> Starting/stopping operation Starting/stopping of pump-only operation (discharge pumps only) Changes to liquid temperature setting Changes to F Parameter settings Start/stop time display setting
Other functions	<ul style="list-style-type: none"> Monitoring functions Alarm history / list confirmation

IMPORTANT

1. This product is a central chiller controller specifically for RKE22000 and 30000B models. It cannot be used with other models.
2. For indoor use only. The product is not waterproof, so do not use it outdoors.
3. Does not have multi-unit control functionality.

Specifications

Model		RKE-CT001	
External Dimensions (H×D×W)		mm	205×183×314
Product Mass		kg	6
Installation Environment	Operable Ambient Temperature Range	°C	0 to 40
	Installation Location		Indoor
Power Specifications	Power Source	V(Hz)	Single-phase, 100 to 200 ±10 V (50/60 Hz)
	Electric Current	A	0.5 or lower
Communication	Standard	Between PLC and TPL1	EIA Standard RS-422A
		Between CPU1 and the RKE chiller unit	EIA Standard RS-485A
	Maximum Number of RKE Unit Connections	kW	16 Units (Up to 4 units per group)
Included Parts.		1. Terminating resistor: 110 Ω, 1/2 W, 1 piece 2. Jumper wire: UL1007 AWG22 1000L, 1 piece	

*This product is a central chiller controller specifically for RKE22000 and 30000B models. It cannot be used with other models.

*The product is not waterproof, so do not use it outdoors. For indoor use only.

*This product is not able to control the number of RKE units running/stopping depending on the user load.

*If mounted on the wall, allow for an open maintenance space of at least 500 mm to the front, and at least 15 mm on the hinge side of the product. Be sure to allow for at least this much open space. If this amount of space is not reserved, then it will not be possible to open the door.

*Communication cables must be purchased as additional accessories (sold separately) or procured locally by the user.

External Dimensions (Units: mm)

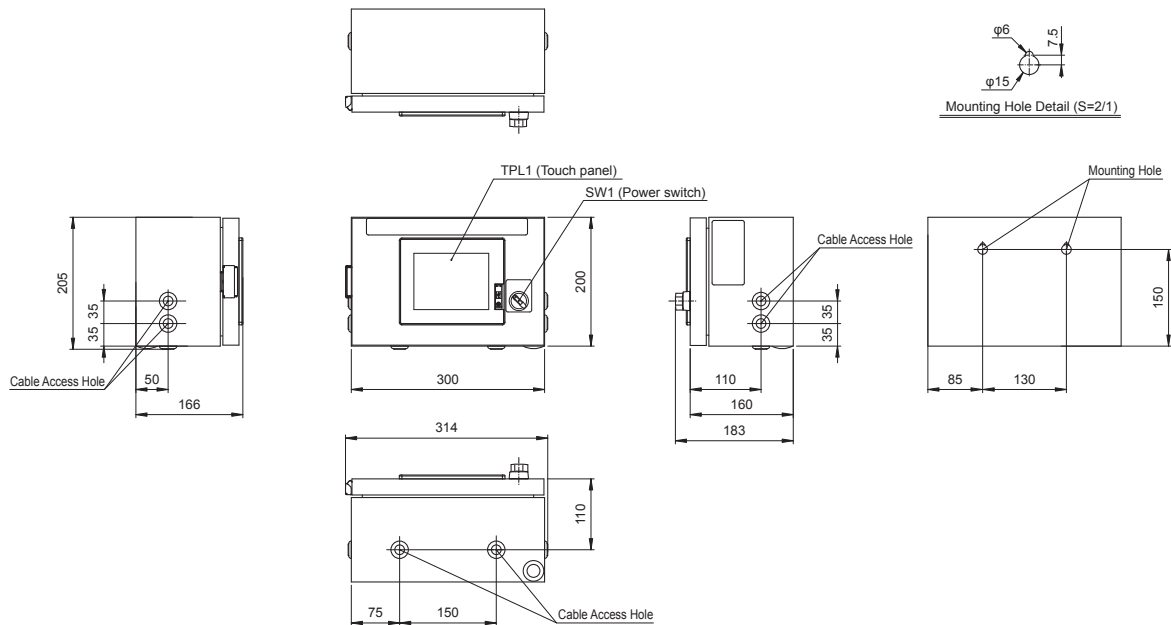

CE Marking Certified Chillers RKE-B Series

Air Cooled Water Cooled

Compliance Standard Low Voltage Directive (2014/35/EU) EMC Directive (2014/30/EU): Industrial Environment
RoHS2 Directive [2011/65/EU+(EU)2015/863]

- Models**
- RKE3750B-V(W)-CE
 - RKE5500B-V(W)-CE
 - RKE7500B-V(W)-CE
 - RKE11000B-V(W)-CE
 - RKE15000B-V(W)-CE



IPX4 Equiv. Rating: Splash-proof Bypass Valve Included as Standard Equipment

TESC Built-In

HCF Refrigerant
 Air Cooled
 Water Cooled
 Inverter [TESC]
 Intelligent Touch Panel
 Low Noise Operation
 IoT* *See page 73.
 IPX4 Equiv. Rating: Splash-proof

Specifications Air Cooled

Model		RKE3750B-V-CE G1 / G2 (w/ casters)	RKE5500B-V-CE	RKE7500B-V-CE	RKE11000B-V-CE	RKE15000B-V-CE		
Performance Specifications	Cooling Capacity *1	kW	12.2	20.3	25.0	37.2	48.0	
	Legal Refrigeration Tonnage		1.31	2.21	2.53	3.98	4.95	
	Heating Capacity *8	kW	2.8	3.7		8.0	10.0	
	Operable Ambient Temperature Range	°C	-20 to 45 (-20 to 50 with an accessory, sold separately)			-20 to 45	-20 to 45 (-20 to 50 with an accessory, sold separately)	
Operable Liquid Temperature Range	°C	3 to 35 (w/ brine: 0 to 35) *7						
Control Precision *4		±0.1 °C (Energy saving mode: ±2.0 °C)						
Operating Flow Rate	L/min	15 to 60	60 to 170		100 to 230			
Power Specifications	Power Source *2	V(Hz)	Three-phase 200 to 220 ±10% (50/60)					
	Power Consumption *1	kW	5.4	9.8	10.2	14.4	18.1	
	Electric Current *1	A	16.5	30.1	33.5	47.0	56.3	
	Power Capacity *3	kVA	7.0	11.0	11.8	19.5	22.0	
	Breaker Capacity *6	A	30	50		75	100	
Operation Control Method		Compressor speed control						
Equipment Details	Compressor	Construction	Fully sealed rotary type (inverter driven)			Fully sealed scroll type (inverter driven)		
		Output	kW	1.7	3.0	4.6	7.46	11.19
	Condenser		Fin and tube forced air cooling					
	Heat Exchanger	Construction	Plate type heat exchanger					
		Material	SUS316 (Brazing: Cu)					
	Discharge Pump	Construction	Multistage centrifugal immersion type					
		Output	kW	1.1 (Inverter driven)	1.5 (Inverter driven)		4.0 (Inverter driven)	
	Fan Motor	Output	kW	0.4 (Inverter driven)	0.75 (Inverter driven)		0.4 × 2 (Inverter driven)	
	Water Tank Capacity	L	Approx. 60	Approx. 90		Approx. 100		
	Refrigerant		R410A					
Charged Amount	kg	2.6	3.1	3.7	5.2	7.0		
External Dimensions (H×D×W)	mm	G1:1410(G2:1536)×752×720	1700×854×870		1700×854×1380	1800×854×1610		
Unit Mass (dry weight)	kg	G1:200 G2:205	280	290	415	460		
Operating Noise Level (50/60 Hz) *5	dB	60	63		69	68		

*1. Operating conditions: Chilled water temp : 20 °C, Ambient temp : 32 °C. Cooling capacity is at least 95% of listed figures. *2. Source voltage phase unbalance should be less than ±3%. *3. The figure noted is when operating at the highest capacity in the normal operating range. *4. Continuous current load fluctuation within ±10%, and with stable ambient temp and power supply, etc. Does not include starting times or when the cooling load is too small, in which case the compressor may cycle on and off. *5. Operating noise levels are from a position of 1 m in front of the unit and at a height of 1 m. *6. Unit comes with a built-in multi-purpose overload and short circuit protection breaker. *7. For liquid temperature settings of 0 to 3 °C, use a 30 to 40% solution of industrial-use ethylene glycol. *8. At time of startup only. Will differ depending on ambient temperature.
 Note 1: The recommended liquid (chilled water) that can be used is either clean water or a 30 to 40% ethylene glycol solution. Note that there will be a 10% reduction in cooling capacity if using a 30 to 40% ethylene glycol solution. Alternatively, if deionized water is to be used, it should have an electrical conductivity of at least 1 μS/cm.
 Note 2: Heat output from the unit (in kW) is approx. 1.3 times that of the cooling capacity.

Cooling Capacity

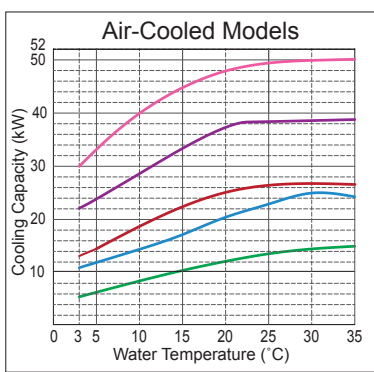

- RKE15000B-V-CE
 - RKE11000B-V-CE
 - RKE7500B-V-CE
 - RKE5500B-V-CE
 - RKE3750B-V-CE
- <Conditions>
- Chilled Liquid : Water
 - Flow Rate : RKE3750B-V-CE 43 L/min
RKE5500B-V-CE + 7500B-V-CE 125 L/min
RKE11000B-V-CE 140 L/min
RKE15000B-V-CE 200 L/min
 - Ambient Temperature : 32 °C

CE Marking Certified Chillers
RKE-B Series

Chilled Water Flow Chart

- * The illustration shows the actual measured flow rate value when the bypass valve is closed.
- * Flow rate changes based on inverter frequency
- * The shaded area indicates the range possible for the adjusted frequency value.
- * If additives are used, the flow rate characteristics will change due to factors such as the additive used, the concentration, fluid temp, etc.

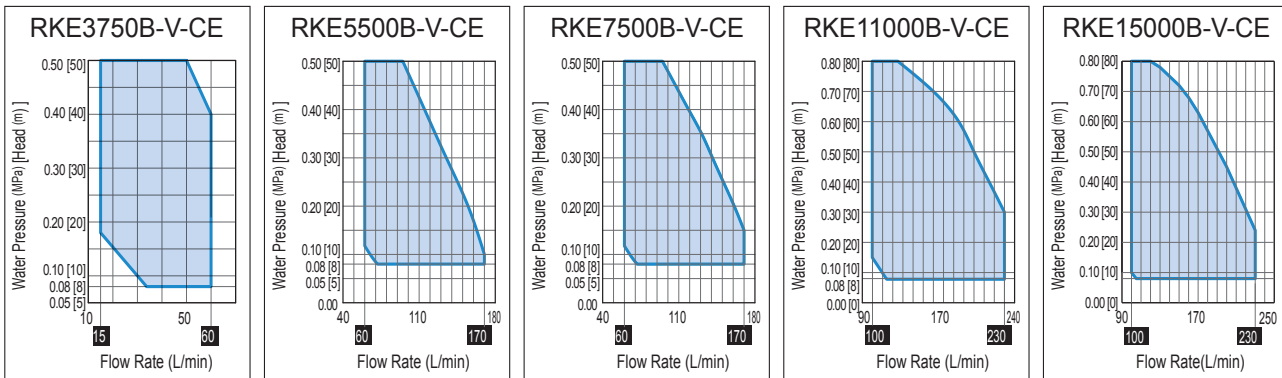

External Dimensions (Units: mm)

RKE3750B-V-CE
RKE5500B-V-CE
RKE7500B-V-CE

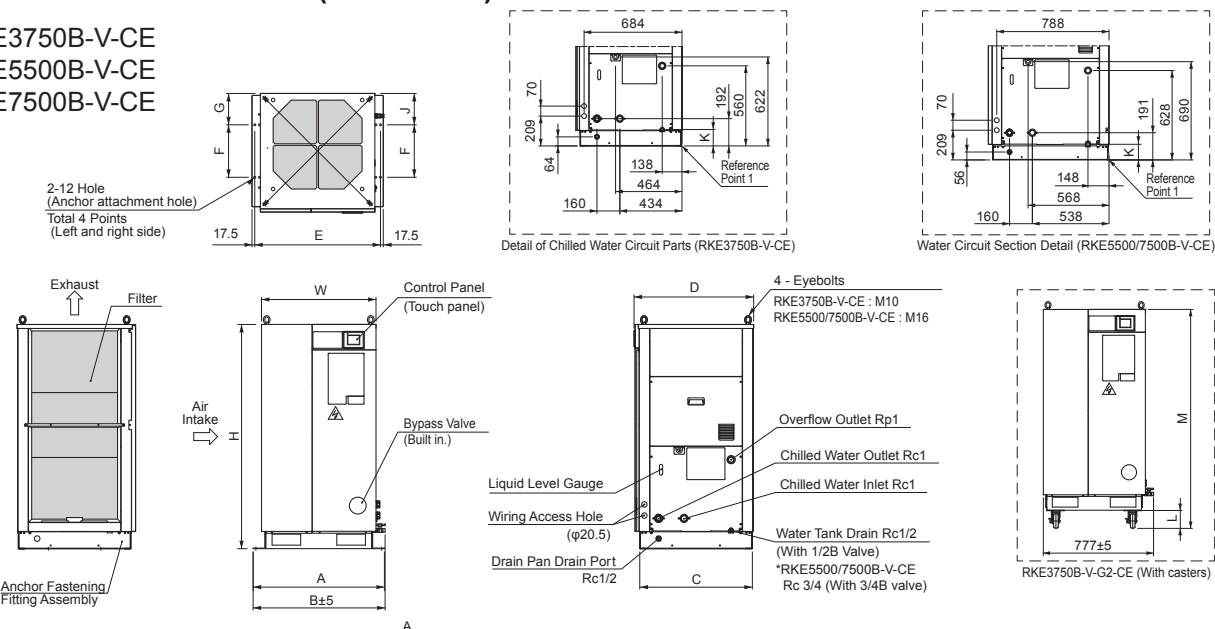

RKE11000B-V-CE
RKE15000B-V-CE

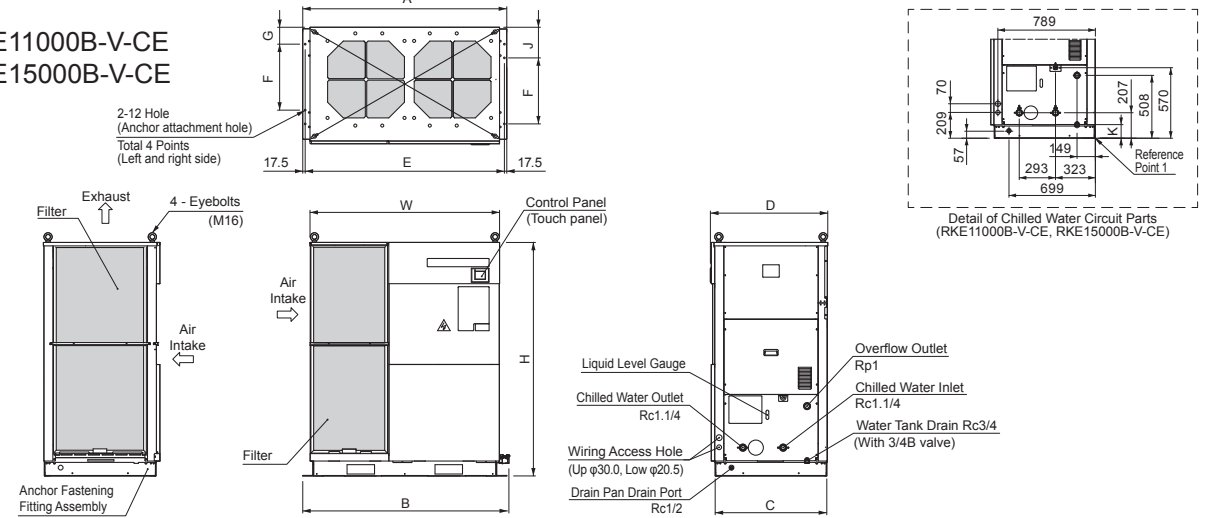

External Dimension Table (units : mm)

Model	W	H	A	B	C	D	E	F	G	J	K	L	M
RKE3750B-V-CE	720	1410	826	830	708	752	791	330	197	197	115	126	1536
RKE5500B-V-CE	870	1700	975	990	812	854	940	480	121	221	110	-	-
RKE7500B-V-CE	1380	1700	1485	1500	812	854	1450	480	123	223	110	-	-
RKE11000B-V-CE	1610	1800	1715	1730	812	854	1680	480	124	224	110	-	-

CE Marking Certified Chillers
RKE-B Series

CE Marking Certified Chillers RKE-B Series

Specifications Water Cooled

Model		RKE3750B-VW-CE G1 / G2 (w/ casters)	RKE5500B-VW-CE	RKE7500B-VW-CE	RKE11000B-VW-CE	RKE15000B-VW-CE	
Performance Specifications	Cooling Capacity *1	kW	14.1	23.4	27.3	43.0	48.0
	Legal Refrigeration Tonnage		1.41	2.25	2.81	4.17	4.95
	Heating Capacity *8	kW	2.8	3.0	3.1	9.1	10.0
	Operable Ambient Temperature Range	°C	-20 to 45(-20 to 50 with an accessory, sold separately)			-20 to 45	-20 to 45 (-20 to 50 with an accessory, sold separately)
	Cooling Water Temperature Range	°C	5 to 45				
	Operable Liquid Temperature Range	°C	3 to 35 (w/ brine: 0 to 35) *7				
	Control Precision *4		±0.1 °C (Energy saving mode: ±2.0 °C)				
Power Specifications	Operating Flow Rate	L/min	15 to 60	60 to 170		100 to 230	
	Power Source *2	V(Hz)	Three-phase 200 ±10% (50) / 200 to 220 ±10% (60)				
	Power Consumption *1	kW	5.1	8.8	10.1	11.7	15.3
	Electric Current *1	A	19.2	31.8	33.0	36.3	48.2
	Power Capacity *3	kVA	8.0	12.2	12.6	17.2	19.5
Breaker Capacity *6	A	30	50		75		
Operation Control Method		Compressor speed control					
Equipment Details	Compressor	Construction	Fully sealed rotary type (inverter driven)			Fully sealed scroll type (inverter driven)	
		Output kW	1.7	3.0	4.6	7.46	11.19
	Condenser	Double pipe water cooling					
		Plate type heat exchanger					
	Heat Exchanger	Construction	SUS316 (Brazing : Cu)				
		Material	Multistage centrifugal immersion type				
	Discharge Pump	Construction	Multistage centrifugal immersion type				
		Output kW	1.1 (Inverter driven)	1.5 (Inverter driven)		4.0 (Inverter driven)	
	Water Tank Capacity	L	Approx. 60	Approx. 90		Approx. 100	
	Refrigerant		R410A				
Charged Amount	kg	2.1	2.6	2.8	3.6		
External Dimensions (H×D×W)	mm	G1:1410×752×720 G2:1536×752×720	1700×854×870			1410×854×1380	
Unit Mass (dry weight)	kg	G1:200 G2:205	280	290	405	405	
Operating Noise Level (50/60 Hz) *5	dB	58	59		61	59	

*1. Operating conditions: Chilled water temp : 20 °C, Cooling water temp : 32 °C (water cooled units only), Ambient temp : 32 °C. Cooling capacity is at least 95% of listed figures. *2. Source voltage phase unbalance should be less than ±3%. *3. The figure noted is when operating at the highest capacity in the normal operating range. *4. Continuous current load fluctuation within ±10%, and with stable ambient temp and power supply, etc. Does not include starting times or when the cooling load is too small, in which case the compressor may cycle on and off. *5. Operating noise levels are from a position of 1 m in front of the unit and at a height of 1 m. *6. Unit comes with a built-in multi-purpose overload and short circuit protection breaker. *7. For liquid temperature settings of 0 to 3 °C, use a 30 to 40% solution of industrial-use ethylene glycol. *8. At time of startup only. Will differ depending on ambient temperature and cooling water temperature.
Note 1: The recommended liquid (chilled water) that can be used is either clean water or a 30 to 40% ethylene glycol solution. Note that there will be a 10% reduction in cooling capacity if using a 30 to 40% ethylene glycol solution. Alternatively, if deionized water is to be used, it should have an electrical conductivity of at least 1 µS/cm.

Cooling Capacity

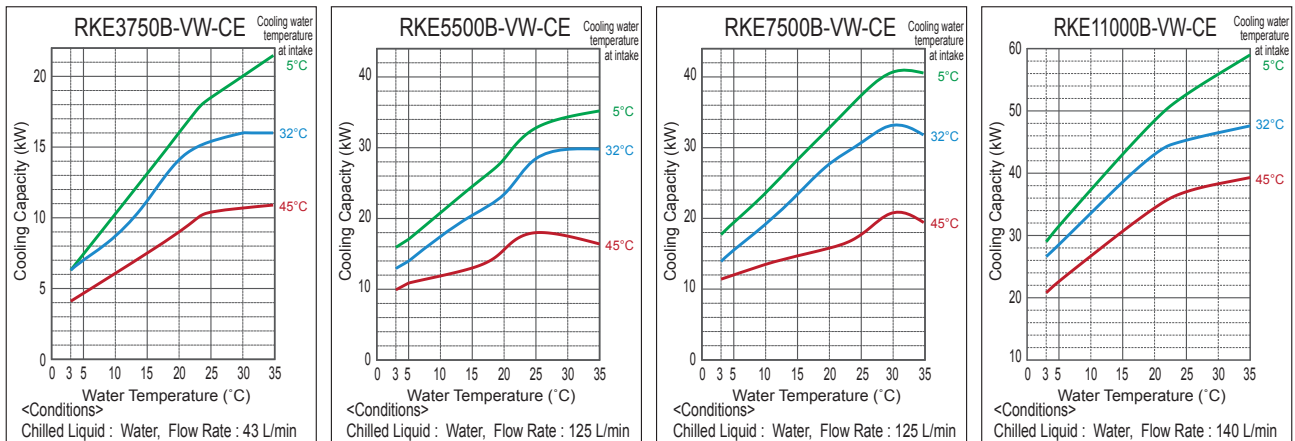

Cooling Water Flow Rate (For the water cooled condenser)

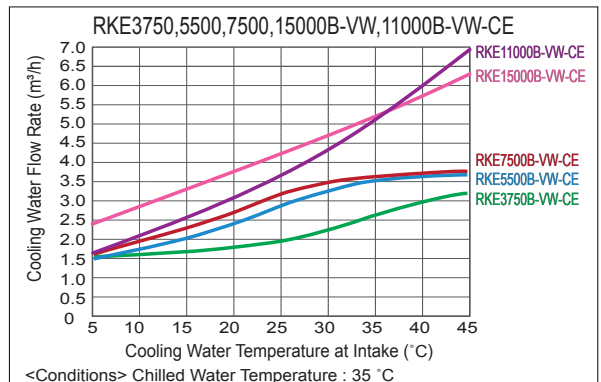

* Actual cooling water flow rate will depend on the water temperature.
* Ensure the required quantity of water as shown in the graphs below.

Chilled Water Flow Chart

- * The illustration shows the actual measured flow rate value when the bypass valve is closed.
- * Flow rate changes based on inverter frequency
- * The shaded area indicates the range possible for the adjusted frequency value.
- * If additives are used, the flow rate characteristics will change due to factors such as the additive used, the concentration, fluid temp, etc.

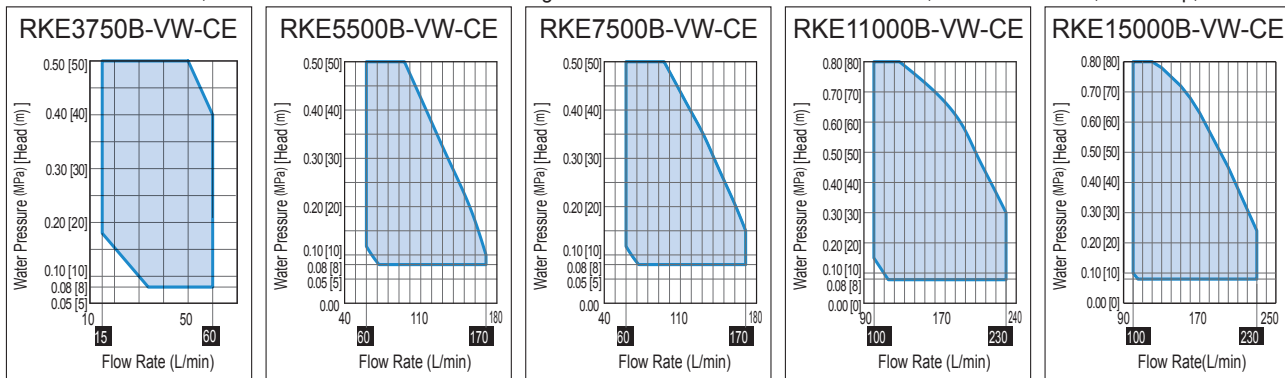

External Dimensions (Units: mm)

RKE3750B-VW-CE
RKE5500B-VW-CE
RKE7500B-VW-CE

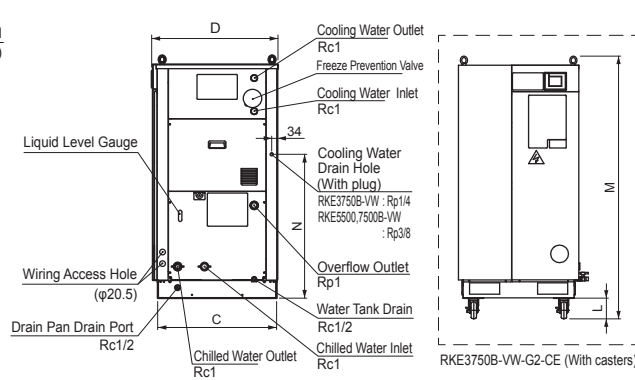
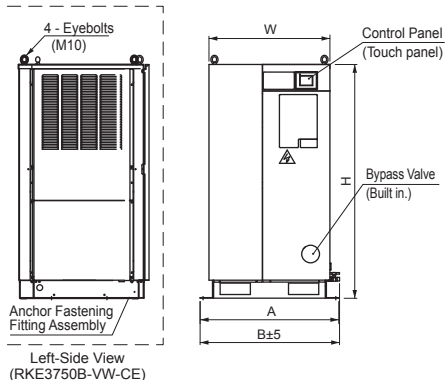
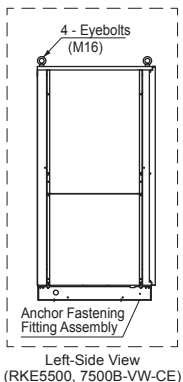
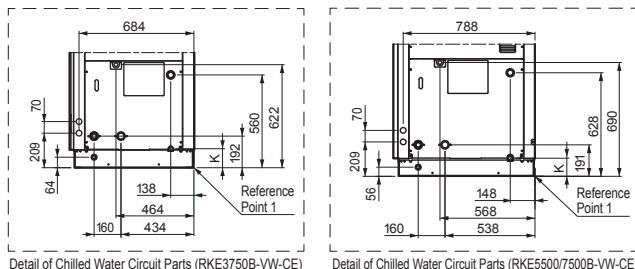
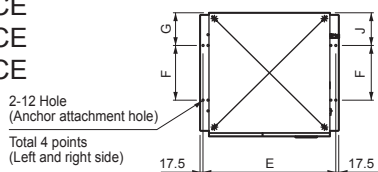

RKE11000B-VW-CE
RKE15000B-VW-CE

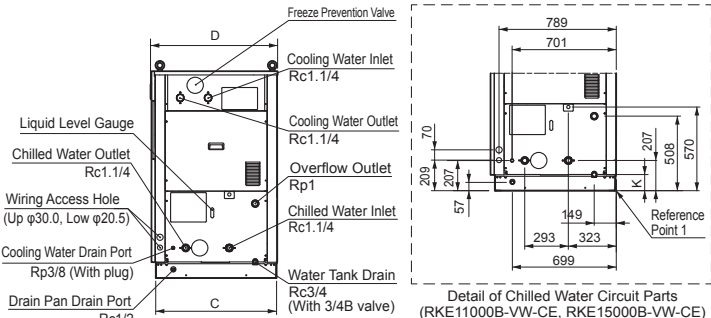
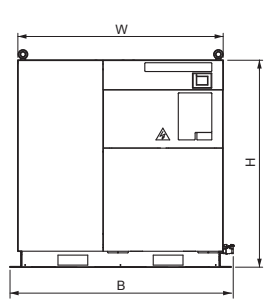
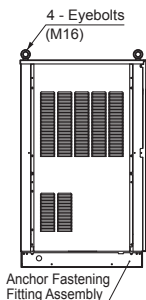
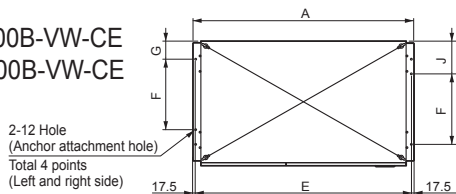

External Dimension Table (units : mm)

Model	W	H	A	B	C	D	E	F	G	J	K	L	M	N
RKE3750B-VW-CE	720	1410	826	830	708	752	791	330	197	197	115	126	1536	869
RKE5500B-VW-CE	870	1700	975	990	812	854	940	480	121	221	110	-	-	939
RKE7500B-VW-CE	870	1700	975	990	812	854	940	480	121	221	110	-	-	939
RKE11000B-VW-CE	1380	1410	1485	1500	812	854	1450	480	123	223	110	-	-	*
RKE15000B-VW-CE	1380	1410	1485	1500	812	854	1450	480	123	223	110	-	-	-

* See External Dimensions

Brine Chiller RKE-B Series

Air Cooled

Models RKE3750B-VL
RKE5500B-VL

IPX4 Equiv. Rating: Splash-proof
Bypass Valve Included as Standard Equipment

Cooling Capacity	3.6 to 8.3 kW
Operable Ambient Temperature Range	-20 to 45 °C
Operable Liquid Temperature Range	-5 to 10 °C
Refrigerant	R410A



RKE5500B-VL

HCF Refrigerant
 Air Cooled
 Inverter [TESC]
 Intelligent Touch Panel
 Low Noise Operation
 IoT* *See page 73.
 IPX4 Equiv. Rating, Splash-proof
 TESC Built-In
 2-year Warranty (or 10,000 hours of operating time)

*Warranty period of the refrigerant circuit is 2 years from the date of purchase (or 10,000 hours of operating time).

Specifications

Model		RKE3750B-VL-G1 (w/o caster)	RKE3750B-VL-G2 (w/ casters)	RKE5500B-VL	
Performance Specifications	Cooling Capacity *1	3.6		8.3	
	Legal Refrigeration Tonnage	1.31		2.21	
	Operable Ambient Temperature Range *9	-20 to 45			
	Operable Liquid Temperature Range	0 to 10 *7			
	Control Precision *4	±0.1 *5 (Energy saving mode: ±2.0)			
Power Specifications	Power Source *2	Three-phase 200V to 220V±10% 50/60Hz			
	Power Consumption *1	4.1		6.8	
	Electric Current *1	15.7		21.3	
	Power Capacity *3	7.0		11.0	
Operation Control Method: Compressor Speed Control					
Equipment Details	Compressor	Construction	Fully sealed rotary type		
		Output kW	1.7(Inverter driven)		3.0(Inverter driven)
	Condenser	Fin and tube forced-air cooling			
		Plate type heat exchanger			
	Heat Exchanger	Construction	SUS316 (Brazing: Cu)		
		Material	SUS316 (Brazing: Cu)		
	Discharge Pump	Construction	Multistage centrifugal immersion type		
		Output kW	1.1(Inverter driven)		1.5(Inverter driven)
		Operating Flow Rate L/min	15 to 60 *10 / 28 to 60 *11		60 to 170
	Fan Motor	Output kW	0.4(Inverter driven)		0.75(Inverter driven)
Water Tank Capacity *8	L	Approx.60		Approx.90	
Refrigerant		R410A			
Charged Amount	kg	2.6		3.1	
External Dimensions (H×D×W)	mm	G1:1410×752×720	G2:1536×752×720	1700×854×870	
Unit Mass (dry weight)	kg	200	205	280	

*1. Operating conditions: Chilled water temp.: 20 °C, Ambient temp.: 32 °C. Cooling capacity is at least 95% of listed figures. *2. Source voltage phase unbalance should be less than ±3%. *3. The figure noted is when operating at the highest capacity in the normal operating range. *4 The setting can be changed by changing parameter F015. *5 When the current load remains within ±10%, the ambient temperature, power supply, etc. are stable, and the chilled water flow rate is 30 L/min or higher. However, the following cases are excluded. (1)Within approximately 4 minutes after the compressor starts up. (Temperature control starts approximately 4 minutes after the compressor starts.) (2)When the compressor cycles on and off with little cooling load or when the electronic expansion valve on the heating side switches from fully closed to open or from open to fully closed. (3)When the current load exceeds ±10%. In this case, the temperature stability will be within ±2.0°C. (4)When the set water temperature is changed. *6 Brine is a 40% to 50% industrial-use ethylene glycol solution. *7 Brine is a 30% to 50% industrial-use ethylene glycol solution. *8 When the liquid level gauge is at "F". *9 Not frozen. *10 When the chilled setting is 5 to 10 °C. *11 When the chilled water setting is -5 to 5 °C.

Note 1: Heat output from the product (in kW) is approx. 1.3 times that of the cooling capacity. (Air-cooled models)

Cooling Capacity

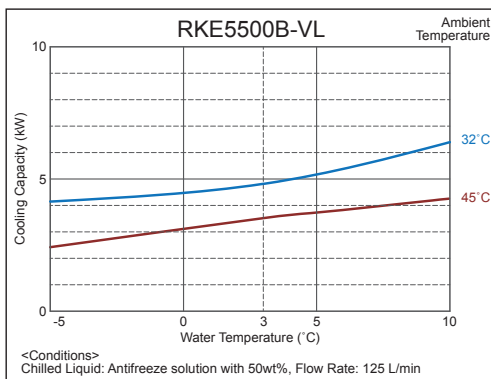
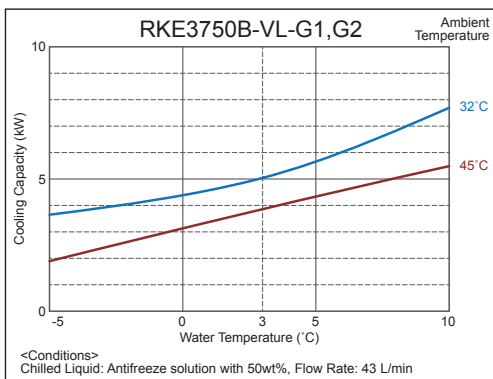

■ Chilled Water Flow Chart

- * The illustration shows the actual measured flow rate value when the bypass valve is closed.
- * Flow rate changes based on inverter frequency.
- * The shaded area indicates the range possible for the adjusted frequency value.
- * If additives are used, the flow rate characteristics will change due to factors such as the additive used, the concentration, fluid temp, etc.

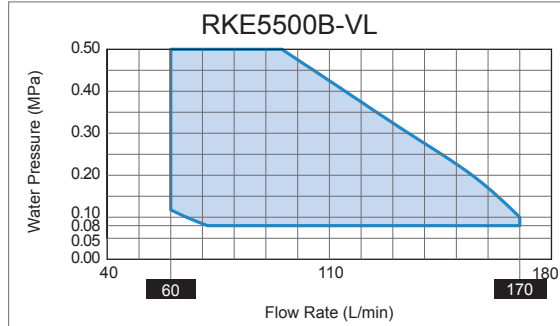
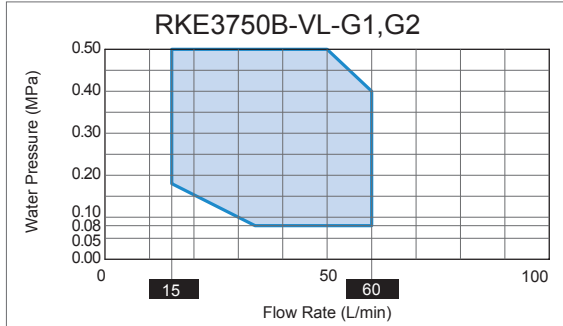

■ External Dimensions (Units: mm)

RKE3750B-VL-G1

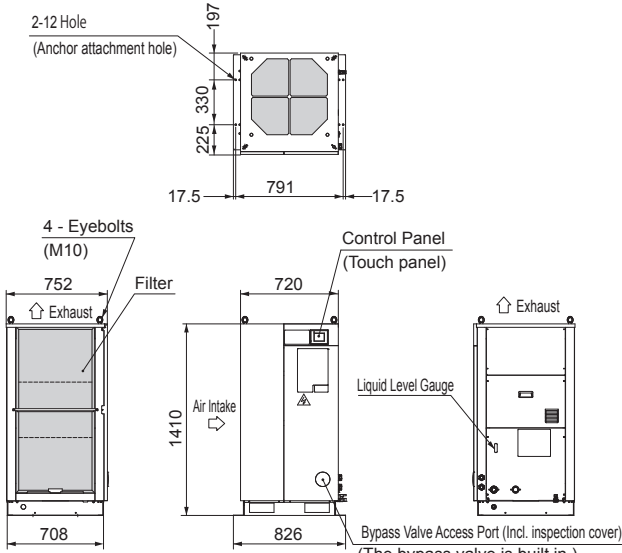

RKE3750B-VL-G1 (w/ casters)

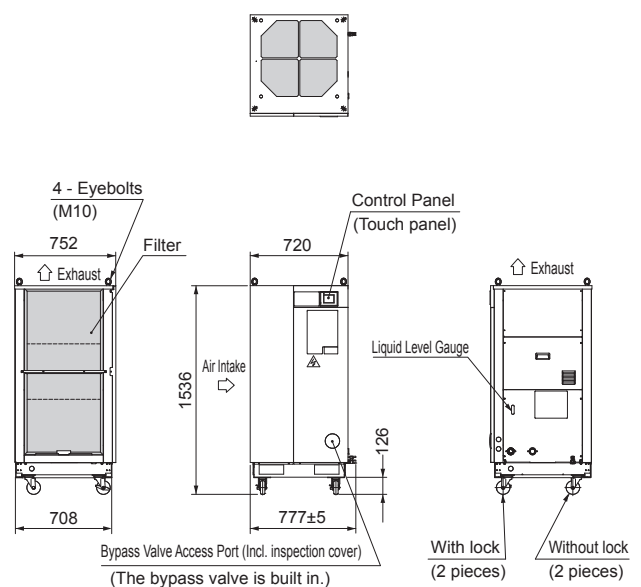

RKE5500B-VL

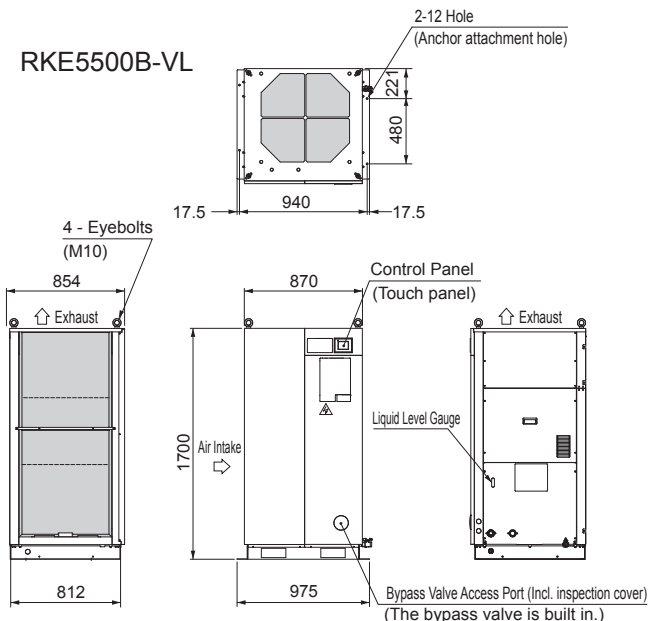

■ Accessories (Sold Separately)

Accessories (Sold Separately)	RKE3750B-VL	RKE5500B-VL
Wind Shield Assembly	03108110010	03108120010
Snow Protection Assembly	03108111010	03108121010
Optional Casters A-Assembly (4 freewheeling casters with lock)	03108408010	03108405010
Optional Casters B-Assembly (4 freewheeling casters with leveling foot)	03108409010	03108406010
Optional Casters C-Assembly (2 freewheeling casters with lock, 2 fixed casters)	03108410010	03108407010
Distribution Panel High-Temperature Set	04105977010	04106046010
Vibration Reducing Base	0A003386010	0A003433010

RKE-A Series

Air Cooled Water Cooled

Cooling Capacity (50 / 60Hz) 57.0 / 60.0 kW(Air Cooled) 57.0 / 60.0 to 96.0 kW(Water Cooled)

Operable Liquid Temperature Range 5 to 35 °C

Models
RKE18000A-V(W)
RKE22000A-VW
RKE30000A-VW

Operable Ambient Temperature Range -5 to 43 °C(Air Cooled) 2 to 43 °C(Water Cooled)

Refrigerant R407C

IPX4 Equiv. Rating: Splash-proof

Bypass Valve Included as Standard Equipment



* Warranty period of the refrigerant circuits 2 years from the date of purchase (or 10,000 hours of operating time).



RKE18000A-V



RKE22000A-VW

Features

1. Operates with a maximum energy savings of 57%. *

These Orion chillers respond to work loads using the least amount of energy. (* Compared with HB control models running at a 30% load)

2. Highly precise liquid temperature control possible.

The chiller senses the liquid temperature and adjusts the compressor speed accordingly, thus achieving liquid temperature precision control of ± 0.5 to ± 1.0 °C. (Precision is subject to work loads. Please consult your dealer if high precision control is demanded.)

Specifications

Model		Air Cooled		Water Cooled		
		RKE18000A-V		RKE18000A-VW		
Performance Specifications	Cooling Capacity (50/60 Hz) *1	kW		57/60		
	Legal Refrigeration Tonnage			5.28/5.89		
	Operable Ambient Temperature range	°C		-5 to 43		
	Operable Liquid Temperature Range	°C		2 to 43		
Power Specifications	Control Precision *4	5 to 35				
	Control Precision *4	Under high precision setting ± 1.0 °C (± 0.5 °C during stable load), under energy-saving setting ± 1.0 °C (± 0.5 °C during stable load, ± 2.0 °C during ON/OFF cycle mode)				
	Power Source *2	V(Hz)		Three-phase 200 $\pm 10\%$ (50/60), 220 $\pm 10\%$ (60)		
	Power Consumption (50/60 Hz, 220 V) *1	kW		25.5/28.0, 28.0		
	Electric Current (50/60 Hz, 220 V) *1	A		82.2/89.8, 89.8		
	Power Capacity *3	kVA		35		
	Breaker Capacity	A		125 *7		
Equipment Details	Compressor Output	kW		3.0, 7.46		
	Condenser			Fin and tube forced air cooling		
	Heat Exchanger	Construction	Plate type heat exchanger			
		Material	SUS316 grade stainless steel (brazing: copper)			
	Discharge Pump	Output	kW		3.2 (inverter driven)	
		Flow Rate *5	L/min		200 (Head: 50 m)	
	Fan Motor Output	W		750 \times 2 (inverter driven)		
	Water Tank Capacity	L		Approx. 160		
	Refrigerant			R407C		
	Charged Amount	kg		6.1, 5.2		
External Dimensions (HxDxW)	mm		1800x960x1720			
Unit Mass (dry weight)	kg		Approx. 660			
Operating Noise Level *6	dB		69			

*1. Operation when liquid temp is 20 °C, ambient temp is 32 °C, and cooling water temp. is 32 °C. Cooling capacity is at least 95% of listed figures. *2. Source voltage phase unbalance should be less than $\pm 3\%$. *3. The figure noted is when the equipment is operating at the highest capacity of its normal operating range. *4. Stable load indicates continued operation with maximum load fluctuations of $\pm 10\%$ of the current load. (However, this is excluding loads in the 25% to 40% range.) Setting can be changed by adjusting parameter F15. (Default setting is the high-precision setting.) *5. Please operate with a head of 50 m or less. *6. Operating noise levels are from a position of 1 m in front of the unit and at a height of 1 m. *7. Unit comes with a built-in multi-purpose overload and short circuit protection breaker. Note 1: Please install the included strainer (40 mesh) to the liquid intake port. Note 2: The recommended liquid (chilled water) that can be used is either clean water or a 30 to 40 % industrial-use ethylene glycol solution. Alternatively, if deionized water is used, it should have an electrical conductivity of at least 1 μ S/cm. Note 3: Heat output of the equipment (in kW) is about 1.3 times the cooling capacity. (Air cooled only.) Note 4: RKE18000A-VW model is a built-to-order item.

■ Cooling Capacity

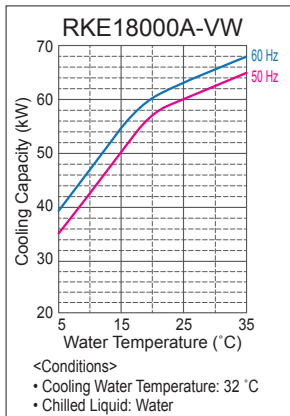
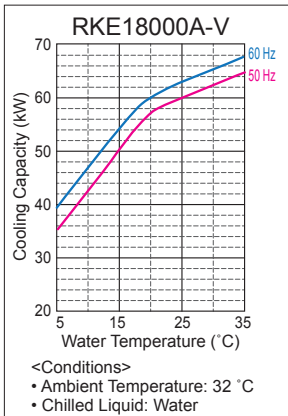

■ Cooling Water Flow Rate (for condenser)

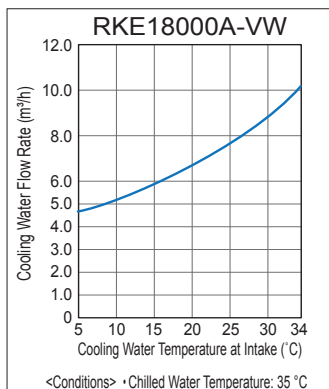

■ Chilled Water Flow Rate

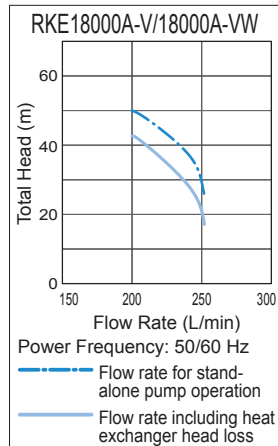

* Internal (return side) Head Loss: 0.7 m or less.

■ External Dimensions (Units: mm)

RKE18000A-V

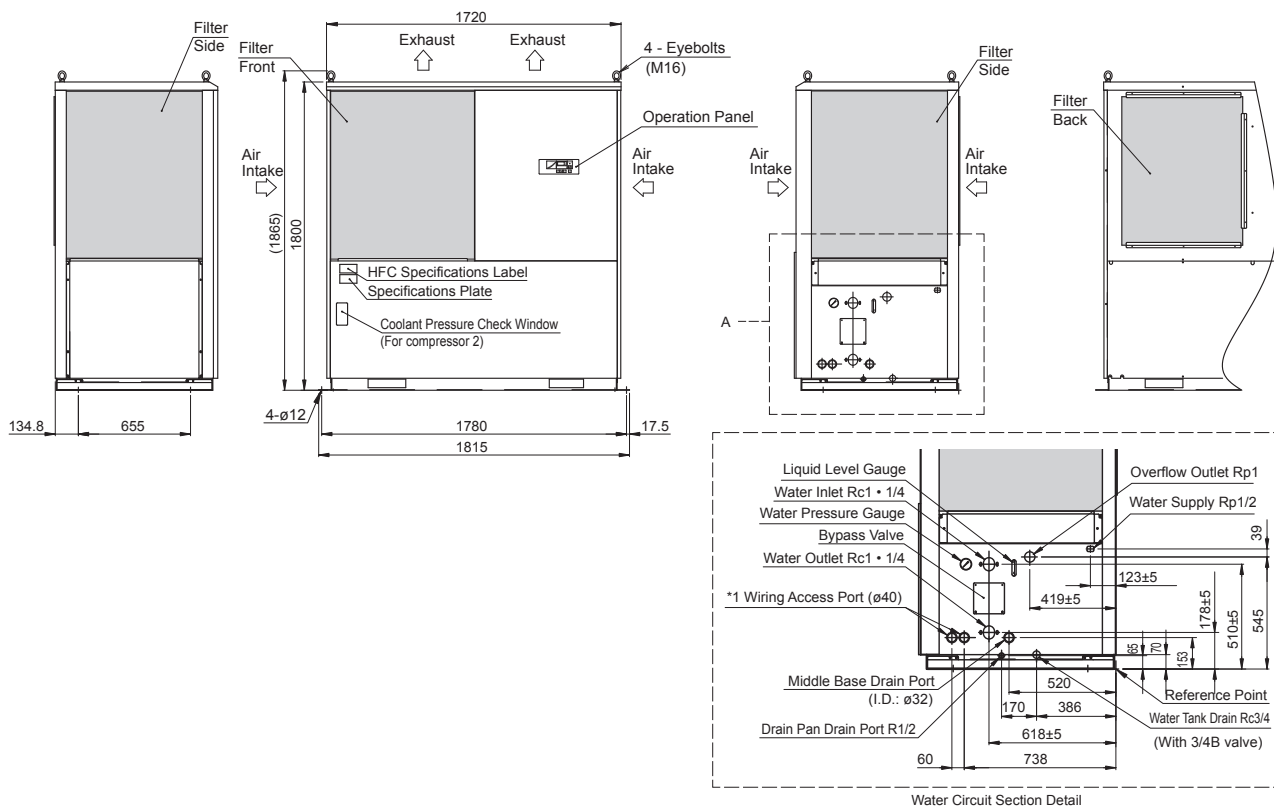

RKE18000A-VV

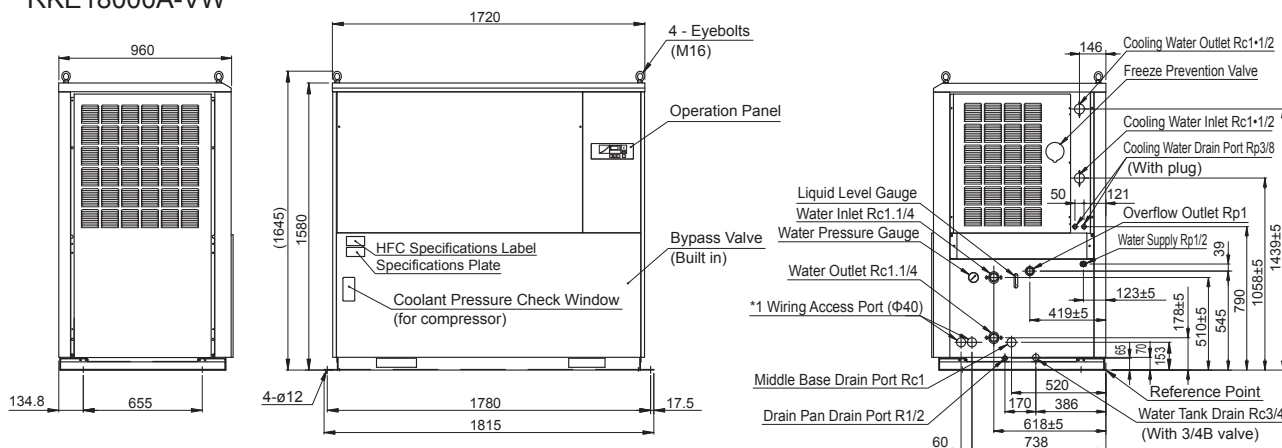

RKE-A Series

Specifications Water Cooled

Model		Water Cooled			
		RKE22000A-VW	RKE30000A-VW		
Performance Specifications	Cooling Capacity (50/60 Hz) *1	kW	70.0/73.0	96	
	Legal Refrigeration Tonnage		8.33/8.94	9.40	
	Operable Ambient Temperature range	°C	2 to 43		
	Operable Liquid Temperature Range	°C	15 to 30		
Control Precision *4			Under high precision setting ± 1.0 °C (± 0.5 °C during stable load), under energy-saving setting ± 1.0 °C (± 0.5 °C during stable load, ± 2.0 °C during ON/OFF cycle mode)		
Power Specifications	Power Source *2	V(Hz)	Three phase 200 $\pm 10\%$ (50/60), 220 $\pm 10\%$ (60)		
	Power Consumption (50/60 Hz, 220 V) *1	kW	38.0/40.0, 40.0	43, 43	
	Electric Current (50/60 Hz, 220 V) *1	A	125/128, 128	126, 126	
	Power Capacity *3	kVA	50.0	54	
Breaker Capacity		A	175 *6		
Equipment Details	Compressor Output		kW	7.5, 7.46	7.5×2
	Condenser		Double pipe water cooling		
	Heat Exchanger	Construction		Plate type heat exchanger	
		Material		SUS316 grade stainless steel (brazing: copper)	
	Discharge Pump	Output		3.2 Inverter driven pump × 2	
		Flow Rate	L/min	Minimum 400 (Head: 50 m)	
	Fan Motor Output		kW	-	-
	Water Tank Capacity		L	Approx. 250	Approx. 320
Refrigerant			R407C		
Charged Amount		kg	6.0, 3.4	6.0×2	
External Dimensions (H×D×W)		mm	1700×1240×2050	1700×1340×2350	
Unit Mass (dry weight)		kg	1100	1420	
Operating Noise Level *5		dB	61	62	

*1. When operating under these conditions: chilled water temperature is 20 °C, ambient temperature is 32 °C, cooling water temperature is 32 °C. Cooling capacity will be at least 95% of the noted figures. *2. Source voltage phase unbalance should be less than $\pm 3\%$. *3. The figure noted is when the equipment is operating at the highest capacity of its normal operating range. *4. Stable load indicates continued operation with maximum load fluctuations of $\pm 10\%$ of the current load. (However, this excludes cases where the electronic capacity control valve cycles on and off.) The setting can be changed by adjusting parameter F15. (Default value: High-precision setting.) *5. Operating noise levels are from a position of 1 m in front of the unit and at a height of 1 m. *6. Unit comes with a built-in multi-purpose overload and short circuit protection breaker. Note 1: Please install the included strainer (40 mesh) to the liquid intake port. Note 2: The recommended liquid (chilled water) that can be used is either clean water or a 30 to 40 % industrial-use ethylene glycol solution. Alternatively, if deionized water is used, it should have an electrical conductivity of at least 1 $\mu\text{S}/\text{cm}$. Note 3: The above two models are built-to-order items.

Cooling Capacity

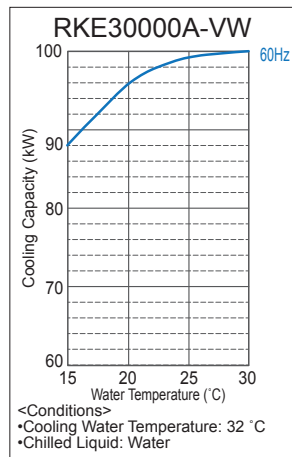
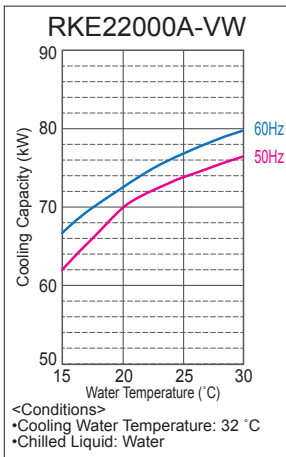

Cooling Water Flow Rate (for condenser)

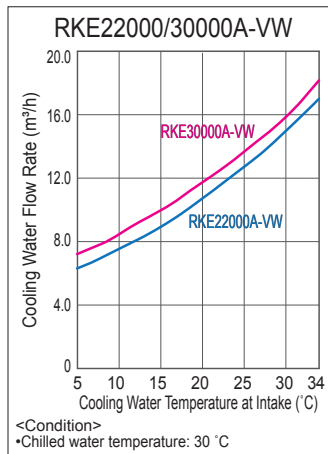

Chilled Water Flow Rate

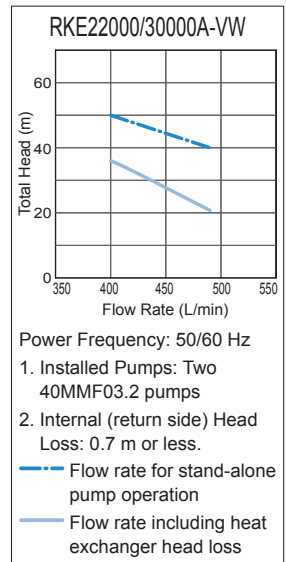

External Dimensions (Units: mm)

RKE22000A-VW

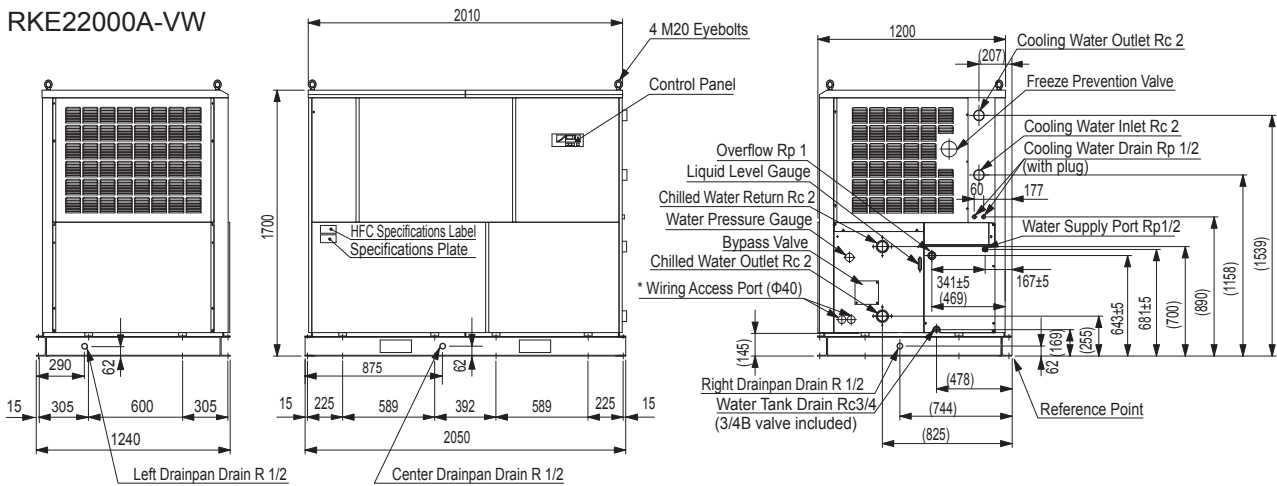

RKE30000A-VW

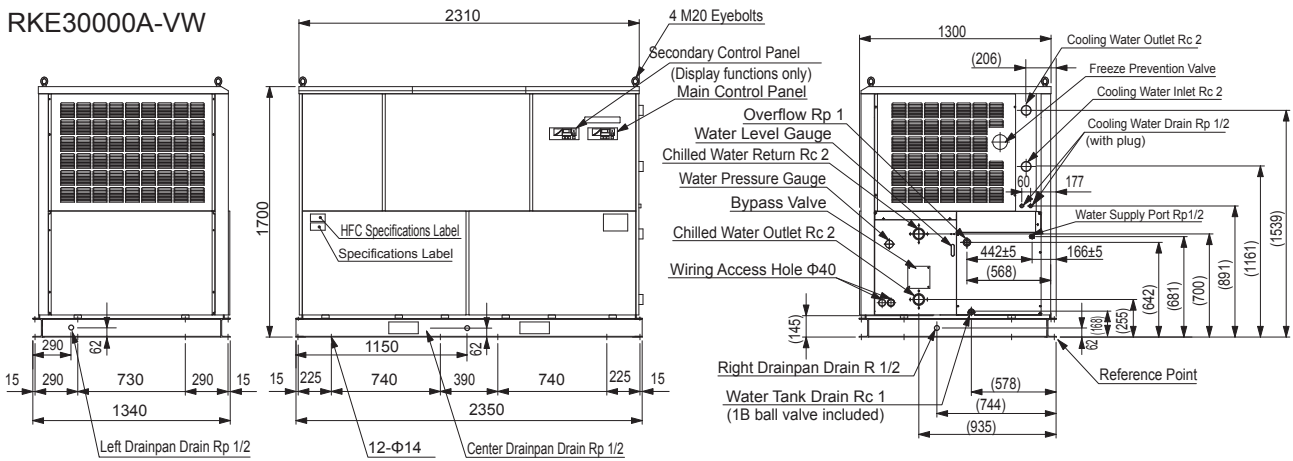

Accessory (Sold Separately) List

Item	Comments	Qty Per Unit	Water-cooled Models		
			Air-cooled Models RKE18000A-V	RKE18000A-VW	RKE22000A-VW
Remote Control (Wired) Set A	Used to perform operations and various settings changes remotely like those done from the product touch panel.	1	04110395010	04110395010	-
Remote Control (Wired) Set B	*The (wired) Remote Control Set does not include the remote control cable.	1	-	-	04110396010
20 m Remote Control Cable	Required when connecting the Remote Control to the main unit. Select from the 3 lengths of remote control cable that meets your use needs.	1	04100541010	04100541010	04100541010
50 m Remote Control Cable		1	04100541020	04100541020	04100541020
100 m Remote Control Cable		1	04100541030	04100541030	04100541030
Wind Protection Panel *	Consider a wind speed of 8 m/s or higher as a guideline.	1	03091363010	-	-
Snow Protection Hood	Prevents falling snow from accumulating on the fan vent.	2	03091238020	-	-
Vibration Isolation Platform	Reduces transmission of vibration from the chiller.	1	0A002244020	0A002244020	-
		1	-	-	0A002245000
Deionizing unit "E" Assembly	Water Quality: 10 μS/cm or lower	1	04100437010	04100437010	-

* Does not include a Wind Protection Panel for the rear side of the product. If the rear-side Wind Protection Panel is required, then it can be ordered as a "special specification" item. (On-site installation is not possible.)

Accessory(Sold Separately) Water Filtering Equipment

Helps to prevent clogging within the water circuit of chillers and other equipment. Can also be used as a pre-filter for water purification equipment.

Features

1. Wall mount type for easy cartridge replacement.
2. Includes ball valves as standard equipment.
3. Stand mount available as an accessory (sold separately).



Water Filter: A-assembly

Water Filter: B-assembly

Specifications

Model		Water Filter: A-Assembly	Water Filter: B-Assembly	Water Filter: C-Assembly
Part number		04100489010	04100491010	04100490010
Applicable Models		RKE3750C-V(W) RKE4500C-V	RKE5500C-V(W) RKE7500C-V(W) RKE9000C-V	RKE11000B1-V(W) *2 RKE15000B-V(W) *2
Operating Ranges	Maximum Working Pressure	MPa	0.5	
	Maximum Working Temperature	°C	50	
Performance Specifications	Degree of Filtration	µm	100	
	Initial Element Pressure Loss	MPa	0.02 (flow rate 43 L/min)	0.02 (flow rate 125 L/min)
Main Dimensions	Piping Connection Size	Rc1/2(Rc1) *1	Rc1	Rc1•1/4
	Mass	kg	6.3	8.0
Element Model Number		SD-100-250-B	SD-100-500-B	
Element Part Number		40605000410	40605000400	
O-ring Part Number		83000014420		

Note: Configuration for use with RKE18000A-V(W) models and higher are special order items.

*1. Can be replaced by removing the 1×½B adaptor bushing. *2. Operate with a chilled water pressure of 0.50 MPa or below. *3 The water filter can be hung on the wall. Please check the mounting space before hanging on the wall. Stand mount is also available as an accessory (sold separately).

External Dimensions

(Units:mm)

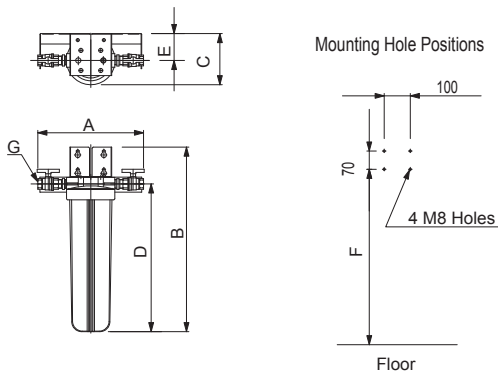

Model	Water Filter:A-Assembly	Water Filter:B-Assembly	Water Filter:C-Assembly
A	(435)	(405)	(449)
B	458	708	715
C	197	197	197
D	312	562	565
E	103	103	103
F	423 min.	673 min.	680 min.
G	Rc1/2	Rc1	Rc1•1/4

Stand Mount (Part No.: 04100569010)

- Works with all filters, Deionizer D-Assembly, and Deionizer E-Assembly.
- 2 filters can be mounted one over the other on a single stand allowing for space saving configurations, such as having a water filter mounted over a deionizing unit.

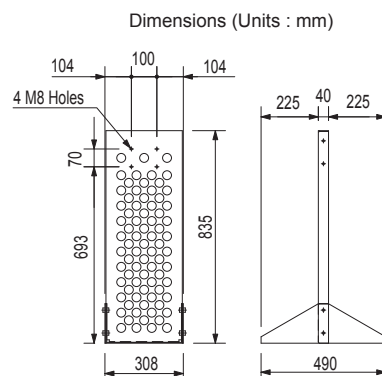

Accessory(Sold Separately) Deionizers

Cartridge and Filter types for easy connections. Water purification without the hassle!

■ **For circulating water setups** (Installed in a bypass configuration, it can help protect against rising electrical conductivity within the water circuit.)



■ Specifications

Model	Deionizer C-Assembly		Deionizer D-Assembly		Deionizer E-Assembly	
Part Number	04100614010		04100597010		04100437010	
Applicable Models	RKE3750C-V(W) RKE4500C-V		RKE5500C-V(W) RKE7500C-V(W) RKE9000C-V		RKE11000B1-V(W) RKE15000B-V(W) RKE18000A-V(W) RKE22000B-V RKE30000B-V	
Ion Exchange Resin	RDI-150		DI-0-10BB		DI-0-20BB	
Ion Exchange Resin Part Number	0A001387000		0A001108000		0A001017000	
Processing Capacity *1 *2	L	Approx. 150	Approx. 600		Approx. 1600	
Water Quality	µS/cm	10 or lower				
Working Water Pressure	MPa	0.05 to 0.20 *5				
Working Water Temperature	°C	5 to 40				
Dimensions	mm	Φ74.5, H : 248 mm (ion exchange resin)	Φ185, H : 449 mm		Φ185, H : 592 mm	
Mass	g	Approx. 670 (ion exchange resin)	Approx. 5700		Approx. 8600	
Type of Installation	On the side of the unit		On a wall *4			
Inlet / Outlet Piping Fixture	-		Rc1/2			
Included Parts	Spare deionizer *3 ball valve, mounting hardware hose nipple, hose band tee coupling, nipple, hose		Mounting bracket, resin nipple, socket, bushing (preassembled on the filter) filter removal wrench			

- *1. Processing capacity figure based on water source standard purity level of 150 µS/cm. Capacity may vary according to water quality.
 *2. Processing capacity is not based on circulating water flow system. Ion exchange resin lifespan and water quality may fluctuate depending on the properties of the wetted parts and surfaces, as well as the particular working environment.
 *3. It is recommended that the initially supplied water be either water that has been purified by having passed through an ion exchange resin, or be commercially purchased deionized water. If tap water (or a similar grade of water) is used, the effective life of the ion exchange resin will be greatly reduced. In this case, please replace the ion exchange resin with the spare soon. (Ion exchange resin assemblies A, B, C, and F only.)
 *4. Ion exchange resin assemblies D and E are wall mounted. Please confirm that there is a suitable installation place before installing the filter. A stand mount is available as an accessory (sold separately). (The mounting hole positions of Ion Exchange Resin D and E assemblies are the same as the mounting hole positions on Water Filter A and B assemblies respectively. Please refer to the Water Filter Equipment page for details regarding dimensions.)
 *5. On Ion Exchange Resin D and E assemblies, if there is a chance that the water pressure within the purification vessel will exceed 0.2 MPa, a pressure reducing valve should be installed.

Note : Avoid installing the ion exchange resin where it will be in direct sunlight or in places where there is a risk of it being damaged.

■ **For Water Supply and Purification** (Keeps sudden rises in electrical conductivity down during water tank supply and replenishment.)

Model	Model Deionizer Assembly for Water Supply	
Part Number	04100522010	
Applicable Purifier	AP-10	
Processing Capacity *1 *2	L	Approx. 2200
Water Quality	µS/cm	1 or less
Working Water Pressure	MPa	0.34 or less *3
Working Water Temperature	°C	5 to 40
Dimensions	mm	Φ165, H : 851 mm
Unit Mass	kg	approx. 15
Inlet Connection	Universal faucet adaptor	
Outlet Connection	Braided hose (ø12 × ø18)	
Ion Exchange Resin Part Number	0A001213000	
Comments	Electrical conductivity gauge (0 – 3 µS/cm) included Flow regulating valve (2.2 L/min) included 3 anchor bolt holes (Φ10 mm × 3)	

- *1 For water tank supply and replenishment.
 *2 Processing capacity figure based on water source standard purity level of 200 µS/cm. Actual processing capacity may change depending on water quality, temperature, etc.
 *3 If there is a chance that the water pressure within the vessel will exceed 0.34 MPa, a pressure reducing valve should be installed.
 Note : Avoid installation of the deionizer where it will be in direct sunlight or in places where there is a risk of it being damaged.



Accessory
(Sold Separately)

Important Unloading and Placement Information RKE-C Series

WARNING = Failure to follow instructions contained in a WARNING may result in death or serious injury.

CAUTION = Failure to follow instructions contained in a CAUTION may result in injury to the operator or damage to property.

Pre-Unloading and Unloading Procedures

• Before Unloading

After unpacking, check the nameplate of the unit to ensure it is the correct model ordered. Also, check that the below mentioned included parts are present.

Machine Part Name	Specifications	Qty Per Unit
Y-Strainer	40 mesh equiv. Pipe connection : 1B Model : RKE3750C-V/VW, RKE4500C-V, RKE5500C-V/VW, RKE7500C-V/VW, RKE9000C-V	1 pc
Barrel Nipple	1B x 100 L (to attach the Y-strainer) Model : RKE3750C-V/VW, RKE4500C-V, RKE5500C-V/VW, RKE7500C-V/VW, RKE9000C-V	1 pc

It is possible that the unit could be damaged during shipping, transport, or other handling. When receiving the unit, check to make sure that there are no scratches or other abnormalities. If any damage or abnormality is detected, please contact the dealer where the unit was purchased.

WARNING

When making use of the eyebolts, suspend the unit from all 4 eyebolts and make sure there is at least a 60° angle between the top face of the unit and each of the suspension cables. Improper suspension may lead to the unit tipping over or falling, which could result in injury.

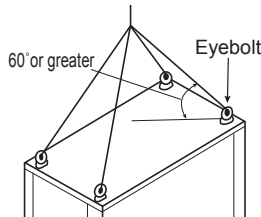

• Unloading Procedure

The unit is heavy; please be careful when transporting it. The unit has rectangular slots at its base in order to accept forklift tines. When lifting the unit by forklift, make sure the forklift tines go through the forklift slots all the way and protrude from the other side of the unit.

Model	Mass (when water tank is empty)
RKE3750C-V-G1 : No casters	207
RKE3750C-V-G2 : Casters included	211
RKE4500C-V-G1 : No casters	207
RKE4500C-V-G2 : Casters included	211
RKE5500C-V	282
RKE7500C-V	296
RKE9000C-V	296
RKE3750C-VW-G1 : No casters	183
RKE3750C-VW-G2 : Casters included	188
RKE5500C-VW	214
RKE7500C-VW	220

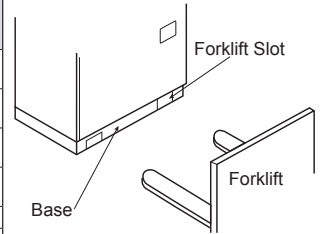

WARNING

Installation of this equipment should be performed by your dealer or other qualified personnel. Improper installation by the end user may lead to water leakage, electric shock, and fire.

Unit Placement

• Choice of Installation Location

Choose an installation location that is free from combustible materials, areas that could lead to electric shock, or environments that could lead to unit breakdown.

CAUTION

Install on a level surface that can adequately support the weight of the unit and fix the unit down with anchor bolts to prevent it from moving around. Not properly installing the equipment as indicated can result in water leaks or injury etc., from the unit tipping over or falling.

- Ensure there is adequate space for heat ventilation as well as sufficient space for maintenance and inspection of the unit. Also note that if the unit is enclosed as in the illustration below, exhaust heat from the unit will be forced back into the unit, causing the refrigerant pressure to rise, and eventually causing the unit to stop.
- If the unit will be installed where a wind of 8 m/s or higher will be blown on it, measures to block the wind from hitting the unit such as installation of a wind-break panel or wall is required.
- Install out of direct sunlight and do not install where the unit would be affected by heat. Contact with direct sunlight or heat can cause the unit to perform below specified performance equal to the amount of that exposure. It can also lead to the activation of built-in safety devices which will prevent unit operation.

Upper Barrier (Roof, eaves, ceiling, etc.)

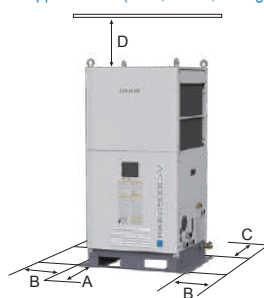
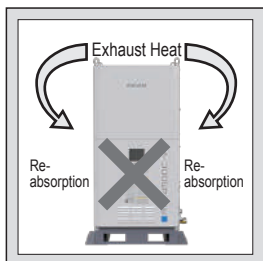

- Air cooled: Operate the unit in the ambient temperature of -20 to 45 °C. Operating outside this temperature range can lead to breakdown of the compressor. And operating in temperatures over 45 °C will result in a drop in the effectiveness of thermal radiation of the condenser. Built-in safety devices may activate causing the unit to shut down. If the ambient temperature will be above 45 °C, install ducting, following the section on page 28, "Ducting Design Points".
Water cooled: Operate the unit in the ambient temperature of 2 to 45 °C. Operating outside this temperature range can lead to breakdown of the compressor.

When performing ductwork, install such that the ducting is not constricted along the way. Failure to follow this rule can also lead to activation of built-in safety devices which will stop unit operation.

- Install in a place that is generally free of dust and dirt. Installation in places with heavy dust and dirt can result in reduction of unit performance.
- Note that operating air-cooled models solely in the Snow-Protection Mode in areas that heavy snowfall will result in reduced performance. It is therefore recommended that the unit be installed away from falling snow. (Air cooled only)
- Operate the product at a cooling water temperature within the range of 5 to 45 °C. If operated outside the specified range, the safety device will be activated to shutdown the product. It can also cause the compressor to malfunction. (Water cooled only)
- The unit contains a slightly flammable refrigerant. When installing indoors, be sure to provide sufficient ventilation and keep fire away from the unit to prevent combustion in the event of refrigerant leakage.

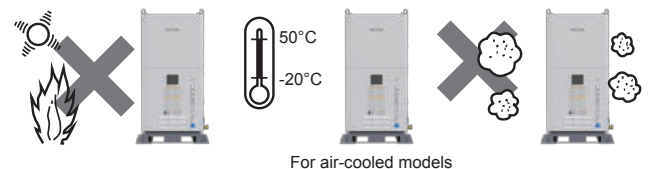

For air-cooled models

RKE-C (Air Cooled)

Model	RKE3750C-V	RKE4500C-V	RKE5500C-V	RKE7500C-V	RKE9000C-V
Maintenance and Inspection Space (cm)	Front View	A	80 or more		
	Left/Right Views	B	80 or more		
	Rear View	C	20 or more		
	Top View	D	200 or more		

RKE-C (Water Cooled)

Model	RKE3750C-VW	RKE5500C-VW	RKE7500C-VW	
Maintenance and Inspection Space (cm)	Front View	A	80 or more	
	Left/Right Views	B	80 or more	
	Rear View	C	0 or more	
	Top View	D	20 or more	

Water Supply and Drainage Construction

- Reliably install water supply and drainage piping. Improper water supply and drainage construction could result in water spraying out, causing water damage to the surrounding area.
- Keep water supply pressure at or below 0.50 MPa. Too high pressure can lead to equipment damage, which may lead to water leaks, flooding of the surrounding area, and electric shock.
- Keep the cooling water pressure below 0.69 MPa. Higher pressure may damage the components to cause water leakage and may result in electric shock.
- When performing water piping, be careful to avoid the following

points. Failure to do so can result in water leakage.

1. Overtightening the piping connected to the water supply port.
2. Having external forces on the water supply port.
3. Piping installation that does not absorb vibrations of water hammer, etc.

- When connecting piping to the water supply port, always use two tools, using one to support the ball tap valve, as shown in the illustration to the right.

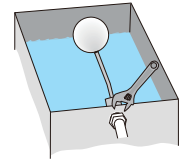

Chilled Water / Cooling Water Piping

• Piping Sizes

Piping diameters for each model are listed below.

Piping Item	Piping Size				
	RKE3750C-V/ VW	RKE4500C-V	RKE5500C-V/ VW	RKE7500C-V/ VW	RKE9000C-V
Chilled Water Inlet			Rc1		
Chilled Water Outlet			Rc1		
Water Tank Drain			Rc1/2		
Overflow Port			Rp1		
Intermediate Base Drain Port			Rc1		
Drain Pan Drain Port			Rc1/2		
Water Supply Port			Rc1/2		
Cooling Water Inlet	Rc1	-	Rc1	Rc1	-
Cooling Water Outlet	Rc1	-	Rc1	Rc1	-

• Piping Methods

Piping installation should follow the guidelines below.

1. Check the cooling water inlet and outlet side ports.
2. Make pipe lengths as short as possible, and also avoid vertical and curved piping as much as possible.
3. When tightening piping connections, use 2 pipe wrenches or adjustable wrenches in order to grasp both sides of the joint.
4. Always install valves (customer supplied) at the chilled water inlet and outlet ports.
5. Install the included Y-strainer on the chilled water intake side port.
6. Make sure that there is no excessive weight or vibration directed on the unit from the connected piping. long horizontal piping should be supported with additional support hardware to ensure unreasonable forces are not applied directly to the unit's connection ports. Failure to properly support piping can lead to equipment damage.
7. Piping should be insulated. (Install the pipe insulation such that there is enough gap to allow the removal of the cabinet water supply port.)
8. If an automatic water supply system is to be installed, be sure to install a valve on the supply port. Also, keep water supply pressure at or below 0.50 MPa.
9. Always support water supply piping with support fittings, and make sure that piping is horizontal.

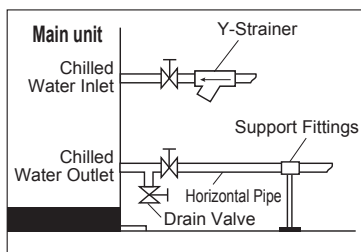

• Pipe Connection Procedure (Water cooled)

1. Confirm the positions of the Cooling Water inlet and outlet. The Cooling Water inlet and outlet are specified with stickers. ("Cooling Water inlet", "Cooling Water Outlet")
2. Follow the instructions below for piping work.
 - (1) Mount the Cooling Water inlet valve <1> and the Cooling Water outlet valve <2>.
 - (2) Be sure to mount the safety relief valve <3>. The regulating valve that is installed in the cooling water circuit performs the opening and closing of the valve automatically by detecting the refrigerant pressure. Thus, there is a possibility that the regulating valve becomes full-closed during operation. Be sure to install the safety relief valve for the water leakage prevention in the cooling water circuit, and set the cooling water inlet pressure 0.69 MPa or lower.
 - (3) Install the purge/drain valve <4>.
 - (4) Be sure to install the union coupling <5>. Make sure that the product and the cooling water piping can be easily disassembled when carrying out the cleaning of water-cooled condenser inside the product.

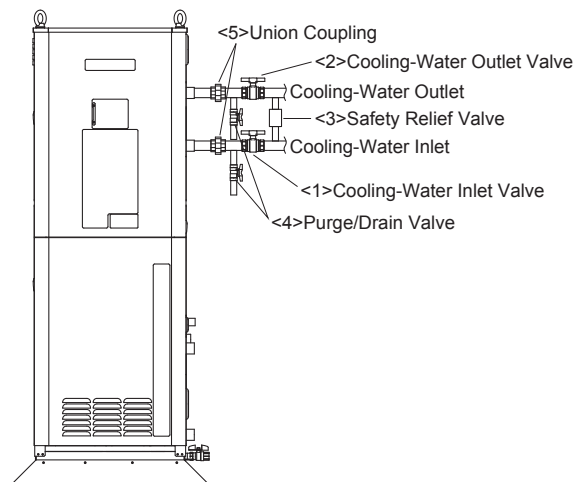

Important Unloading and Placement Information

Electrical Wiring

• Correct Wiring Installation

When performing electrical wiring, be sure to carefully follow the guidelines listed below.

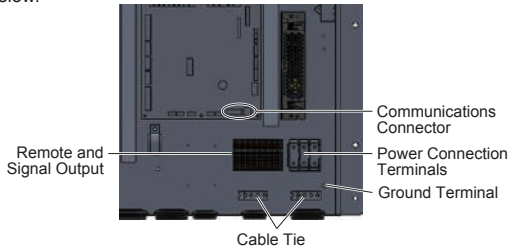

1. Choose a power cable based on the breaker capacity shown in the table to the right. Hook up the ground wire to the earth (ground) terminal located in the distribution box. Also, regarding the power and signal terminal block, refer to the chart on the right for the screw size and terminal block width.
2. There is a combined use overload protection and earth leakage breaker installed inside the distribution box and the specifications are in the table to the right.
3. Route the power cord through the power cord access hole, located on the lower-right part of the unit, to the inside of the terminal box. (Use 1 of the 2 available power cord access holes. The other can be used for remote control panel connections, etc.) Connect the power cord to the L1, L2, and L3 terminals on the terminal block. Fix the power cord in place with a cable tie.
4. Always properly ground this unit. Connect the ground wire to a proper earth/ground point that has been installed by a qualified electrician. Furthermore, the diameter of the grounding wire must be at least 2 mm². * Prepare the ground wire terminal of a size according to the screw size listed in the table to the right.
5. Ensure the source voltage is within ±10% of the specified voltage. Also make sure the source voltage phase unbalance is within ±3%.

		RKE3750C-V/VW RKE4500C-V	RKE5500C-V/VW	RKE7500C-V/VW RKE9000C-V
Power Source (V·Hz)	Air cooled	Three-phase 200 to 220 ±10% (50/60)		
	Water cooled	Three-phase 200 to 220 ±10% (60)		
Terminal Block	Screw Size	M5		
	Terminal Block Width (mm)	Ferrule terminal: Conductive sleeve length: 8 to 10 mm Wire size: 0.08 mm ² to 1.5 mm ² Recommended part: Toyogiken Manufactured "TA Series" (Stranded wire connection: Remove 10 to 11 mm of insulation)		
	Power	13		
	Signal	3.5		

	RKE3750C-V/VW RKE4500C-V	RKE5500C-V/VW	RKE7500C-V/VW RKE9000C-V
Breaker Capacity (A)	30	50	
Current Sensitivity (mA)	30		
Ground Terminal	M5		

* Phase unbalance (%) = (Maximum voltage [V] - Minimum voltage [V]) ÷ Average voltage of 3 phases (V) × 67. (Based on IEC61800-3.)

<IMPORTANT>

- Make sure the power cord does not come into contact with the refrigerant piping or any motor within the unit. Contact with hot surfaces could cause the cord to melt, resulting in an electrical short. (Secure the power cable with the cable tie inside the distribution box.)
- Never operate the unit when the water circuit is empty. Always fill the water tank and confirm the water level before operating.
- Do not attempt to perform withstand voltage tests or insulation resistance tests. Doing so can damage the semiconductors used in the chiller control board or inverter. If the tests are deemed necessary, please consult with your dealer.

If Employing Remote Control Operation

• Information Regarding Remote Operation and Communications Functions

Perform the wiring after confirming the required specifications.

* Please prepare terminals that fit M3 size screws.

1. Please confirm the unit specifications which are as follows.

Remote Operation Input Specifications	<ul style="list-style-type: none"> • No-voltage contacts input (alternate switch) • Maximum cable length: 20 m • Input resistance: 1200 Ω • Open circuit voltage (Voc): 12 V DC • Short circuit current (Isc): 10 mA DC
Signal Output Terminals (Operating Signal, Alarm Signal, Temp. Warning Signal)	<ul style="list-style-type: none"> • No-voltage relay contact output (Form C contacts) • 250 Vac / 30 Vdc, 5 A (resistance load) (normally open) • 250 Vac / 30 Vdc, 3 A (resistance load) (normally closed) • Minimum operating current (for reference only) 5 Vdc, 10 mA
Signal Output Terminals (Discharge Pump Operating Signal)	<ul style="list-style-type: none"> • No-voltage relay contact output (Form C contacts) • 240 Vac / 24 Vdc, 5 A (resistance load) (normally open) • 240 Vac / 24 Vdc, 3 A (resistance load) (normally closed)

2. Remote operation and signal output terminals are as follows:

Remote Operation Terminals	Remote Operation	20			
	Remote Discharge Pump Operation	21			
Signal Output Terminals	Operating Signal	22	23	24	When power source is cut off: 24 – 26 closed, 25 – 26 open
	Alarm Signal	25	26	27	Unit operation is stopped and the unit is operating in pump-only mode: 24 – 26 closed, 25 – 26 open
		26	27	28	Equipment operating: 24 – 26 open, 25 – 26 closed
		27	28	29	When power source is cut off: 27 – 29 closed, 28 – 29 open
	Temp. Warning Signal	28	29	30	No alarm : 27 – 29 closed, 28 – 29 open (initial setting)
		29	30	31	During alarm: 27 – 29 open, 28 – 29 closed (initial setting)
	Discharge Pump Operating Signal	30	31	32	When power source is cut off: 30 – 32 closed, 31 – 32 open
		31	32	33	No temperature warning: 30 – 32 closed, 31 – 32 open (initial setting)
		32	33	34	During temperature warning: 30 – 32 open, 31 – 32 closed (initial setting)
		33	34	35	When power source is cut off: 33 – 35 closed, 34 – 35 open
	34	35		Discharge pump operating: 33-35 closed, 34-35 open (Factory default setting)	
	35			Discharge pump stopped: 33-35 open, 34-35 closed (Factory default setting)	

•When Using Communications Functions

USB	<ul style="list-style-type: none"> • Connector: USB type B connector • Data cable max. length: 3 m. * May differ depending on specific operating conditions.
RS-422A (RS-485)	<ul style="list-style-type: none"> • Attach the stripped wires and use as is. • Data cable wire size: AWG16 – 26 • Data cable max. length: 100 m. (from host to terminal end) * May differ depending on specific operating conditions.
LAN	Connection to a LAN is possible by installing an optional accessory (sold separately).

• Communication Protocol

Modbus-RTU Protocol (Factory default setting) / ORION Protocol

• Communications Cables and Connectors

1. USB

<1> Compatible connector: Type B (male) connector

<2> Maximum cable length: 3 m. However, it may be shorter depending on actual operating conditions.

2. RS-422A (RS-485)

(1) Connector: Terminal block

(2) Cable Gauge: AWG16 – 26 (Use AWG18 – 24 if 2 wires are to be inserted into a single terminal connection.)

(3) Length of Insulation to Remove From Cable: 10 mm

(4) Attaching the Cables: Use either of the following methods: Attach the stripped wires as is. When performing hookups, be careful not to allow frayed wires to come into contact with or short out nearby wiring.

(5) Maximum Cable Length: 100 m or less -- May differ depending on operating conditions.

(6) Connection Example

* If connecting via RS-422A/485, make the connection by purchasing and using an RS-232C/422A converter.

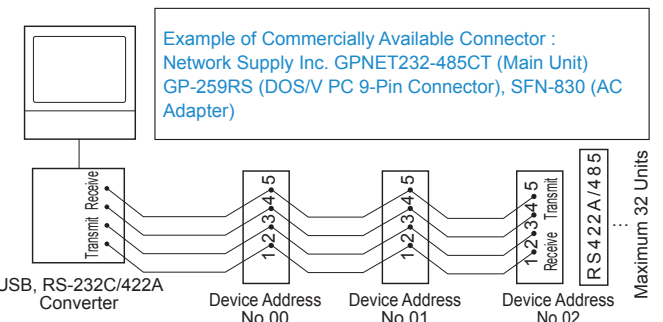

Ducting Design Points (Air cooled only)

• **Ducting Design Points (For User Installed Ducting)**

If the area where the unit is to be installed is narrow or has a low ceiling, the ambient temperature could raise to above 45 °C from the heat coming from the ventilation outlet. In such cases, ducting should be used to move the heat outside of the room or at least away from the unit so that the effects of it do not cause the temperature around the unit to rise. Take the following into consideration when planning duct work.

1. Duct cross sectional area

(1) For duct that rises up:

	RKE3750C-V	RKE4500C-V	RKE5500C-V
Minimum Cross Sectional Area (m ²) [B×W]	0.35		
Maximum Length (m)	20		

	RKE7500C-V	RKE9000C-V
Minimum Cross Sectional Area (m ²) [B×W]	0.45	
Maximum Length (m)	20	

(2) Rectangular ducting with bends:

- The cross sectional area should be greater than above, and Lx and Ly should be less than 2 m. (See Fig. 1.)
- If the length of Lx and Ly go over 2 m, then there should be a 20 cm gap between the hot exhaust air outlet from the unit and a fan should be installed on the duct outlet. Do not allow Lx and Ly to be longer than 5 m. (See Fig. 2.)

▶ **Fig. 1 Examples of Bent Rectangular Ducting**

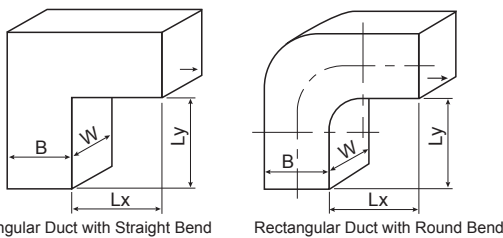

* The duct in the figure is one example. The particular direction the duct exhaust port goes from the unit does not matter, however the following important points must be enforced.

▶ **Fig. 2 : Duct installation method when Lx and Ly exceed 2 m.**

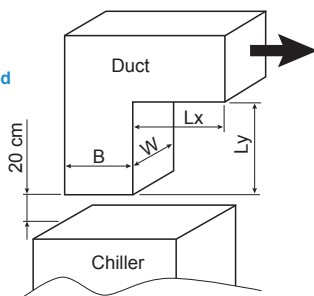

Model	RKE3750, 4500, 5500C-V	RKE7500, 9000C-V
Recommended Fan	50 Hz power (Mitsubishi Electric Corporation)	EJ-80FTC3 (Mitsubishi Electric Corporation)
	60 Hz power (Mitsubishi Electric Corporation)	EWG-60FTA (Mitsubishi Electric Corporation)
Minimum Required Airflow (m ³ /min)	119	186

<IMPORTANT>

Do not have anything such as walls or other obstacles that could obstruct exhaust output within 2 m of the unit in the direction of the duct exhaust output. Failure to follow this rule will result in decreased air flow, the main unit heat ventilation will be insufficient, and built-in safety devices may activate, which would cause unit operation to stop.

• **Installing Ducting on the Unit**

If ducting is to be affixed to the unit, first remove the suspension eyebolts from the top and replace them with M size bolts of the appropriate size. In this case, install ducting such that at least 500 mm of ducting above the product can be removed when needed in order to allow for easy fan maintenance and inspection.

Model	A	B	C	D	E	M Screw
RKE3750, 4500C-V	720	732	22.3	675.4	685.4	M16
RKE5500, 7500, 9000C-V	880	872	24.3	831.4	825.4	M16

Unit : mm

<IMPORTANT>

- If ducting is to be affixed directly on the unit, be sure to install support hardware along the ducting in order to prevent the unit from tipping over.

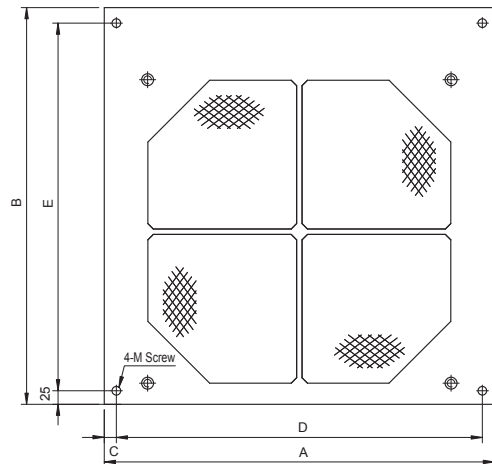

Important Unloading and Placement Information

Points to Follow to Achieve Performance Specifications

Important Points to Ensure Optimum Product Performance

- Note the operating ranges and always operate the unit within these ranges. Operating outside the designated ranges can lead to unit breakdown.

Clause	RKE3750C-V/VW, RKE4500C-V, RKE5500C-V/VW, RKE7500C-V/VW, RKE9000C-V
Ambient Temp Range (°C)	-20 to 50 (Air cooled) / 2 to 45 (Water cooled)
Liquid Temp Range (°C)	5 to 35
Power (V·Hz)	200 to 220 ±10% (50/60)
Discharge Pump Operating Pressure (Mpa)	0.08 to 0.50

- Do not use aluminum parts for parts that will be wetted with the chilled water. The unit's water circuits operate with parts made of copper or copper alloys, so if user-installed wetted parts containing aluminum are present, the resulting copper ions will lead to electrolytic corrosion and copper deposits, which can cause water leakage around mechanical seals and clogging in the heat exchanger.
- Please consult your dealer before using any corrosion inhibiting water additives. Troubles such as the water becoming dirty, or damage to the refrigeration unit from clogging etc. can result depending on the type of additive used.
- Always apply power to the unit at least 12 hours before performing initial test runs or after the unit has been unpowered for 24 hours or more. Failure to apply power in advance as directed can lead to damage to the refrigeration compressor.
- Operating with antifreeze or rust inhibitor additives can reduce the lifespan of the mechanical seals.

Chilled Water

Chilled Water Standards

The recommended liquid (chilled water) that can be used is either clean water (see chart below for water quality standard) or a 30 to 40% ethylene glycol solution. Alternatively, if deionized water is to be used, it should have

	Item	Standard Levels
Standard Components	pH (25 °C)	6.8 – 8.0
	Conductivity (µS/cm) (25 °C)	1 – 400
	Chloride Ion (mgCl ⁻ /L)	Max. 50
	Sulphate (mgSO ₄ ²⁻ /L)	Max. 50
	Acid Consumption (pH 4.8) (mgCaCO ₃ /L)	Max. 50
	Total Hardness (mgCaCO ₃ /L)	Max. 70
	Calcium Hardness (mgCaCO ₃ /L)	Max. 50
	Silica Ion (mgSiO ₂ /L)	Max. 30

<IMPORTANT>

Do not operate with the discharge pump circuit (cooling water inlet/outlet) blocked. Operating the unit with the circuit blocked can result in freezing or damage of the evaporator, breakdown of the discharge pump, disconnection of hoses, or other trouble.

- When using brine for freeze-prevention, use either a 30-50% industrial-use ethylene glycol solution, or a 30 to 70% industrial-use propylene-glycol solution. (The cooling capacity will drop approx. 10%.)
- Frequent starting and stopping can lead to unit breakdown. Allow at least 5 minutes between starting and stopping the unit. If the unit is started less than 5 minutes after stopping, warning "C064" or "C065" will be generated.
- Always fill the water tank and check the water level before operating. If the water level gauge goes below the "E" mark, alarm "E006" will occur and the unit cannot be operated.
- The water pressure at the water supply port should be 0.50 MPa or less. Too high pressure will result in the water supply failing to shut off or leakage.
- Always keep the water clean, inspect the water circuits monthly, and replace the water when necessary.
- Clean the condenser filter every month.
- Water cooled: The cooling water should be checked monthly to ensure that it is clean. The water should be changed if dirty.

an electrical conductivity of at least 1 µS/cm. Cooling non-approved liquid can result in equipment damage, leaking, and possible electric shock or electrical shorts.

	Item	Standard Levels
Reference Components	Iron (mgFe/L)	Max. 1.0
	Copper (mgCu/L)	Max. 1.0
	Sulfide Ion (mgS ²⁻ /L)	Not detected
	Ammonium Ion (mgNH ₄ ⁺ /L)	Max. 1.0
	Residual Chlorine (mgCl/L)	Max. 0.3
	Free Carbon Dioxide (mgCO ₂ /L)	Max. 4.0

* Excerpt from JRA-GL-02-1994 guidelines from The Japan Refrigeration and Air Conditioning Industry Association.

Cooling Water

Water Selection

Water for the water-cooled condenser may be ground water, municipal water, or cooling-tower water. Refer to the following water quality standard for guidance in selecting the water type.

Water Quality Standard Guidelines

Primary cooling water (refrigeration unit condenser cooling water, constant temperature water for the water temperature controller, and humidification water) should meet the water quality standard as described in the chart on the right

1. Standard Concentration Levels for Primary Cooling Water

- If tap water is used as the primary cooling water for water cooled equipment, then the water should meet the following water quality standard.
- "○" marks in a tendency column show the factor related to either corrosion or scale generation tendency.
- The 15 items listed to the right are the primary components that can lead to corrosion or scaling.

	Clause	Cooling Water		Tendencies	
		Circulation Water	Supplied Water	Corrosion	Scaling
Standard Items	pH (25 °C)	6.5 to 8.2	6.0 to 8.0	○	○
	Electric Conductivity (µS/cm) (25 °C)	800 or below	300 or below	○	○
	Chloride Ion (mgCl ⁻ /L)	200 or below	50 or below	○	
	Sulfate Ion (mgSO ₄ ²⁻ /L)	200 or below	50 or below	○	
	Acid Consumption (pH4.8) (mgCaC ₂ /L)	100 or below	50 or below		○
	Total Hardness (mgCaCO ₃ /L)	200 or below	70 or below		○
	Calcium Hardness (mgCaCO ₃ /L)	150 or below	50 or below		○
	Ionic Silica (mgSiO ₂ /L)	50 or below	30 or below		○
Reference Items	Iron (mgFe/L)	1.0 or below	0.3 or below	○	○
	Copper (mgCu/L)	0.3 or below	0.1 or below	○	
	Sulfide Ion (mgS ²⁻ /L)	None detected	None detected	○	
	Ammonium Ion (mgNH ₄ ⁺ /L)	1.0 or below	0.1 or below	○	
	Residual Chlorine (mgCl/L)	0.3 or below	0.3 or below	○	
	Free Carbon Dioxide (mgCO ₂ /L)	4.0 or below	4.0 or below	○	
	Stability Index	6.0 to 7.0	–	○	○

* Excerpt from JRA-GL-02-1994 guidelines from The Japan Refrigeration and Air Conditioning Industry Association.

Important Unloading and Placement Information RKE-B Series

⚠ WARNING = Failure to follow instructions contained in a WARNING may result in death or serious injury.

⚠ CAUTION = Failure to follow instructions contained in a CAUTION may result in injury to the operator or damage to property.

Pre-Unloading and Unloading Procedures

• Before Unloading

After unpacking, check the nameplate of the unit to ensure it is the correct model ordered. Also, check that the below mentioned included parts are present.

Machine Part Name	Specifications	Qty Per Unit
Y-Strainer	40 mesh equiv. Pipe connection : 1B Model : RKE3750B-V/VW/VL, RKE5500B-V/VW/VL, RKE7500B-V/VW	1 pc
	40 mesh equiv. Pipe connection : 1.1/4B Model : RKE11000B1-V/B1-VW, RKE15000B-V/B-VW	
	40 mesh equiv. Pipe connection : 2B Model : RKE22000B-V, RKE30000B-V	
Barrel Nipple	1B x 100 L (to attach the Y-strainer) Model : RKE3750 - 7500B-V/B-VW	1 pc
	1.1/4B x 100 L (to attach the Y-strainer) Model : RKE11000B1-V/B1-VW, RKE15000B-V/B-VW	
	2B (to attach the Y-strainer) Model : RKE22000B-V, RKE30000B-V	

It is possible that the unit could be damaged during shipping, transport, or other handling. When receiving the unit, check to make sure that there are no scratches or other abnormalities. If any damage or abnormality is detected, please contact the dealer where the unit was purchased.

⚠ WARNING

When making use of the eyebolts, suspend the unit from all 4 eyebolts and make sure there is at least a 60° angle between the top face of the unit and each of the suspension cables. Improper suspension may lead to the unit tipping over or falling, which could result in injury.

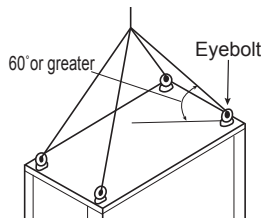

• Unloading Procedure

The unit is heavy; please be careful when transporting it. The unit has rectangular slots at its base in order to accept forklift tines. When lifting the unit by forklift, make sure the forklift tines go through the forklift slots all the way and protrude from the other side of the unit.

Model	Mass (when water tank is empty)
RKE3750B-V/VW/VL-G1 : No casters	200 kg
RKE3750B-V/VW/VL-G2 : Casters included	205 kg
RKE5500B-V/VW	280 kg
RKE7500B-V/VW	290 kg
RKE11000B1-V	415 kg
RKE11000B1-VW	405 kg
RKE15000B-V	460 kg
RKE15000B-VW	405 kg
RKE22000B-V	1050kg
RKE30000B-V	1065kg

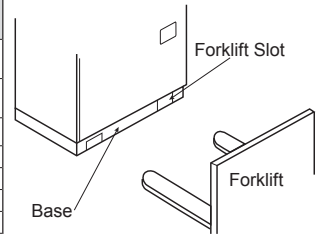

⚠ WARNING

Installation of this equipment should be performed by your dealer or other qualified personnel. Improper installation by the end user may lead to water leakage, electric shock, and fire.

Unit Placement

• Choice of Installation Location

Choose an installation location that is free from combustible materials, areas that could lead to electric shock, or environments that could lead to unit breakdown.

⚠ CAUTION

Install on a level surface that can adequately support the weight of the unit and fix the unit down with anchor bolts to prevent it from moving around. Not properly installing the equipment as indicated can result in water leaks or injury etc., from the unit tipping over or falling.

1. Ensure there is adequate space for heat ventilation as well as sufficient space for maintenance and inspection of the unit. Also note that if the unit is enclosed as in the illustration below, exhaust heat from the unit will be forced back into the unit, causing the refrigerant pressure to rise, and eventually causing the unit to stop.
2. If the unit will be installed where a wind of 8 m/s or higher will be blown on it, measures to block the wind from hitting the unit such as installation of a wind-break panel or wall is required.
3. Install out of direct sunlight and do not install where the unit would be

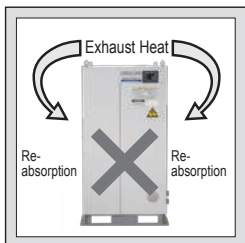

* If there are no obstacles within 150 cm of the front and sides of the unit, then the space from the top of the unit to the obstacle above can be as low as 100 cm or higher.

* For RKE22000B-V and 30000B-V models, ensure there is at least 300 cm clearance above the product and there are no obstacles within 100 cm of the front, back and sides. Model in the illustration: RKE3750B-V.



affected by heat. Contact with direct sunlight or heat can cause the unit to perform below specified performance equal to the amount of that exposure. It can also lead to the activation of built-in safety devices which will prevent unit operation.

4. Air cooled: Operate the unit in the ambient temperature of -20 to 45 °C. Operating outside this temperature range can lead to breakdown of the compressor. And operating in temperatures over 45 °C will result in a drop in the effectiveness of thermal radiation of the condenser. Built-in safety devices may activate causing the unit to shut down. If the ambient temperature will be above 45 °C, install ducting, following the section on page 81, "Ducting Design Points".
- Water cooled: Operate the unit in the ambient temperature of 2 to 45 °C. Operating outside this temperature range can lead to breakdown of the compressor.

When performing ductwork, install such that the ducting is not constricted along the way. Failure to follow this rule can also lead to activation of built-in safety devices which will stop unit operation.

5. Install in a place that is generally free of dust and dirt. Installation in places with heavy dust and dirt can result in reduction of unit performance.
6. Note that operating air-cooled models solely in the Snow-Protection Mode in areas that heavy snowfall will result in reduced performance. It is therefore recommended that the unit be installed away from falling snow. (Air cooled only)
7. Operate the product at a cooling water temperature within the range of 5 to 45 °C. If operated outside the specified range, the safety device will be activated to shutdown the product. It can also cause the compressor to malfunction. (Water cooled only)

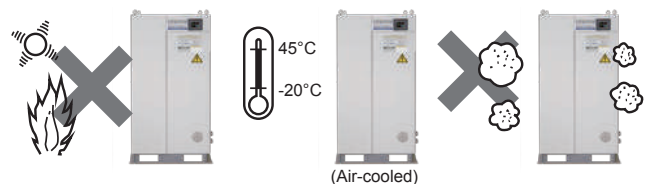

	RKE3750B-V	RKE3750B-V(L)	RKE5500B-V(L)	RKE7500B-V	RKE11000B1-V	RKE15000B-V	RKE22000B-V	RKE30000B-V
Maintenance and Inspection Space (cm)	Front View			80				100
	Left/Right Views			80				100
	Rear View			0				100
	Top View				200			300

Water Supply and Drainage Construction

- Reliably install water supply and drainage piping. Improper water supply and drainage construction could result in water spraying out, causing water damage to the surrounding area.
- Keep water supply pressure at or below 0.50 MPa. Too high pressure can lead to equipment damage, which may lead to water leaks, flooding of the surrounding area, and electric shock.
- Keep the cooling water pressure below 0.69 MPa. Higher pressure may damage the components to cause water leakage and may result in electric shock.
- When performing water piping, be careful to avoid the following

points. Failure to do so can result in water leakage.

1. Overtightening the piping connected to the water supply port.
2. Having external forces on the water supply port.
3. Piping installation that does not absorb vibrations of water hammer, etc.

- When connecting piping to the water supply port, always use two tools, using one to support the ball tap valve, as shown in the illustration to the right.

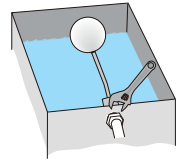

Chilled Water / Cooling Water Piping

• Piping Sizes

Piping diameters for each model are listed below.

Piping Item	Piping Size		
	RKE3750B-V/VW/VL	RKE5500B-V/VW/VL RKE7500B-V/VW	RKE11000B1-V/VW RKE15000B-V/VW
Chilled Water Inlet	Rc1		Rc1.1/4
Chilled Water Outlet	Rc1		Rc1.1/4
Water Tank Drain	Rc1/2	Rc3/4	
Overflow Port	Rp1 (excluding -VL)		
Drain Pan Drain Port	Rc1/2		
Water Supply Port	PJ1/2 (excluding -VL)		
Cooling Water Inlet	Rc1 (Water cooled only)		Rc1.1/4 (Water cooled only)
Cooling Water Outlet	Rc1 (Water cooled only)		Rc1.1/4 (Water cooled only)

Piping Item	Piping Size	
	RKE22000B-V, RKE30000B-V	
Chilled Water Inlet	Rc2	
Chilled Water Outlet	Rc2	
Water Tank Drain	Rc1	
Overflow Port	Rp1	
Drain Pan Drain Port	R1/2	
Water Supply Port	PJ1/2	
Pressure Equalization Port*	R4	

* Only used for linked units.

• Piping Methods

Piping installation should follow the guidelines below.

1. Check the chilled water inlet and outlet ports.
2. Make pipe lengths as short as possible, and also avoid vertical and curved piping as much as possible.
3. When tightening overflow piping connections, use 2 pipe wrenches or adjustable wrenches in order to grasp both sides of the joint.
4. Always install valves (customer supplied) at the chilled water inlet and outlet ports.
5. Install the included Y-strainer on the chilled water intake side port.
6. Make sure that there is no excessive weight or vibration directed on the unit from the connected piping. Long horizontal piping should be supported with additional support hardware to ensure unreasonable forces are not applied directly to the unit's connection ports. Failure to properly support piping can lead to equipment damage.
7. Piping should be insulated. (Install the pipe insulation such that there is enough gap to allow the removal of the cabinet water supply port.)
8. If an automatic water supply system is to be installed, be sure to install a valve on the supply port. Also, keep water supply pressure at or below 0.50 MPa.
9. Always support water supply piping with support fittings, and make sure that piping is horizontal.

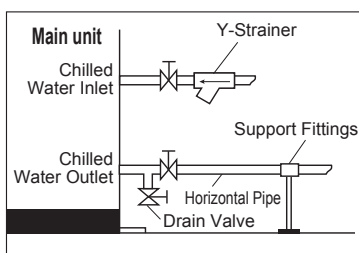

• Pipe Connection Procedure (Water cooled)

1. Confirm the positions of the Cooling Water inlet and outlet. The Cooling Water inlet and outlet are specified with stickers.
2. Follow the instructions below for piping work.
 - (1) Mount the Cooling Water inlet valve <1> and the Cooling Water outlet valve <2>.
 - (2) Be sure to mount the safety relief valve <3>. The regulating valve that is installed in the cooling water circuit performs the opening and closing of the valve automatically by detecting the refrigerant pressure. Thus, there is a possibility that the regulating valve becomes full-closed during operation. Be sure to install the safety relief valve for the water leakage prevention in the cooling water circuit, and set the cooling water inlet pressure 0.69 MPa or lower.
 - (3) Install the purge/drain valve <4>.
 - (4) Be sure to install the union coupling <5>. Make sure that the product and the cooling water piping can be easily disassembled when carrying out the cleaning of water-cooled condenser inside the product.

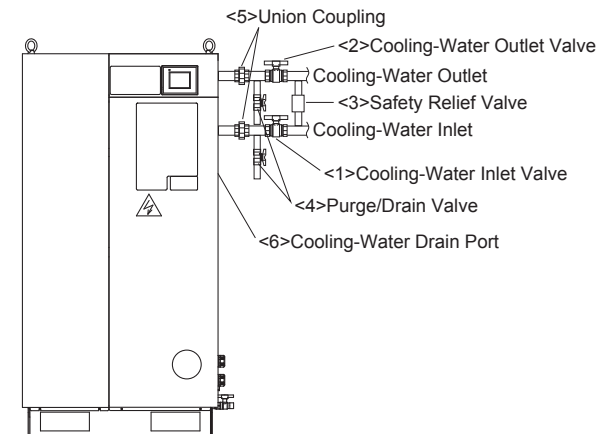

Electrical Wiring

• Correct Wiring Installation

When performing electrical wiring, be sure to carefully follow the guidelines listed below.

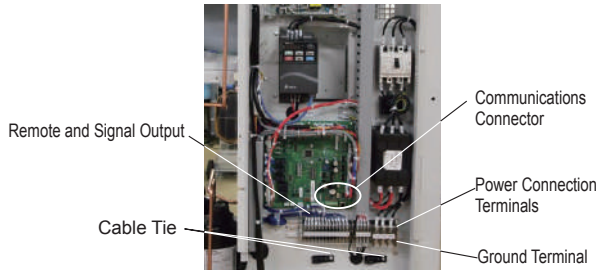

1. Choose a power cable based on the breaker capacity shown in the table to the right. Hook up the ground wire to the earth (ground) terminal located in the distribution box. Also, regarding the power and signal terminal block, refer to the chart on the right for the screw size and terminal block width.
 2. There is a combined use overload protection and earth leakage breaker installed inside the distribution box and the specifications are in the table to the right.
 3. Route the power cord through the power cord access hole, located on the lower-right part of the unit, to the inside of the terminal box. (Use 1 of the 2 available power cord access holes. The other can be used for remote control panel connections, etc.) Connect the power cord to the L1, L2, and L3 terminals on the terminal block. Fix the power cord in place with a cable tie.
 4. Always properly ground this unit. Connect the ground wire to a proper earth/ground point that has been installed by a qualified electrician. Furthermore, the diameter of the grounding wire must be at least 2 mm².
- * Prepare the ground wire terminal of a size according to the screw size listed in the table to the right.
5. Ensure the source voltage is within ±10% of the specified voltage. Also make sure the source voltage phase unbalance is within ±3%.
- * Phase unbalance (%) = (Maximum voltage [V] - Minimum voltage [V]) ÷ Average voltage of 3 phases (V) × 67. (Based on IEC61800-3.)

		RKE3750B-V/VW/VL	RKE5500B-V/VW/VL, 7500B-V/VW	RKE11000B1, 15000B-V/VW	
Power Source (V•Hz)	Air cooled	Three-phase 200 to 220 ±10% (50/60)			
	Water cooled	Three-phase 200 ±10% (50), 200 to 220 ±10% (60)			
Terminal Block	Screw Size	Power	M5	M6	
		Signal	M3		
	Terminal Block Width (mm)	Power	12	13	17
		Signal	5.9		

	RKE3750B-V/VW/VL	RKE5500B-V/VW/VL, 7500B-V/VW	RKE11000B1-V/VW	RKE15000B-V	RKE15000B-VW
Breaker Capacity (A)	30	50	75	100	75
Current Sensitivity (mA)	30			100	

	RKE3750B-V/VW/VL	5500B-V/VW/VL, 7500B-V/VW	RKE11000B1, 15000B-V/VW
Ground Terminal	M5		M6

		RKE22000B-V	RKE30000B-V
Power Source (V•Hz)		Three-phase 200 to 220 ±10% (50/60)	
Terminal Block	Screw Size	Power	M8
		Signal	M3
	Terminal Block Width (mm)	Power	23
		Signal	5.9
Breaker Capacity (A)	125	175	
Current Sensitivity (mA)	100		
Ground Terminal	M8		

<IMPORTANT>

- Make sure the power cord does not come into contact with the refrigerant piping or any motor within the unit. Contact with hot surfaces could cause the cord to melt, resulting in an electrical short. (Secure the power cable with the cable tie inside the distribution box.)
- Never operate the unit when the water circuit is empty. Always fill the water tank and confirm the water level before operating.
- Do not attempt to perform withstand voltage tests or insulation resistance tests. Doing so can damage the semiconductors used in the chiller control board or inverter. If the tests are deemed necessary, please consult with your dealer.

If Employing Remote Control Operation

• Information Regarding Remote Operation and Communications Functions

Perform the wiring after confirming the required specifications.

* Please prepare terminals that fit M3 size screws.

1. Please confirm the unit specifications which are as follows.

Remote Operation Input Specifications	<ul style="list-style-type: none"> • No-voltage contacts input (alternate switch) • Maximum cable length: 20 m • Input resistance: 1200 Ω • Open circuit voltage (Voc): 12 V DC • Short circuit current (Isc): 6 mA DC
Signal Output Specifications	<ul style="list-style-type: none"> • No-voltage relay contact output (c contact) • 250 Vac / 30 Vdc, 5 A (resistance load) (normally open) • 250 Vac / 30 Vdc, 3 A (resistance load) (normally closed) • Minimum operating current (for reference only) 5 Vdc, 10 mA

2. Remote operation and signal output terminals are as follows:

Remote Operation Terminals	Remote Operation	20	
	Remote Discharge Pump Operation	21	
Signal Output Terminals	Operating Signal	22	
		23	
		24	When power source is cut off: 24 – 26 closed, 25 – 26 open
	Alarm Signal	25	Unit operation is stopped: 24 – 26 closed, 25 – 26 open
		26	Unit operating: 24 – 26 open, 25 – 26 closed
		27	When power source is cut off: 27 – 29 closed, 28 – 29 open
	Temp. Warning Signal	28	No alarm : 27 – 29 closed, 28 – 29 open (initial setting)
		29	During alarm: 27 – 29 open, 28 – 29 closed (initial setting)
30		When power source is cut off: 30 – 32 closed, 31 – 32 open	
		31	No temperature warning: 30 – 32 closed, 31 – 32 open (initial setting)
		32	During temperature warning: 30 – 32 open, 31 – 32 closed (initial setting)

•When Using Communications Functions

USB	<ul style="list-style-type: none"> • Connector: USB type B connector • Data cable max. length: 3 m. * May differ depending on specific operating conditions.
RS-422A (RS-485)	<ul style="list-style-type: none"> • Attach the stripped wires and use as is. • Data cable wire size: AWG16 – 26 • Data cable max. length: 100 m. (from host to terminal end) * May differ depending on specific operating conditions.

• Communication Protocol

ORION Protocol

• Communications Cables and Connectors

1. USB

<1> Compatible connector: Type B (male) connector

<2> Maximum cable length: 3 m. However, it may be shorter depending on actual operating conditions.

2. RS-422A (RS-485)

(1) Connector: Terminal block

(2) Cable Gauge: AWG16 – 24 (Use AWG18 – 24 if 2 wires are to be inserted into a single terminal connection.)

(3) Length of Insulation to Remove From Cable: 10 mm

(4) Attaching the Cables: Use either of the following methods: Attach the stripped wires as is. When performing hookups, be careful not to allow frayed wires to come into contact with or short out nearby wiring.

(5) Maximum Cable Length: 100 m or less -- May differ depending on operating conditions.

(6) Connection Example

* If connecting via RS-422A/485, make the connection by purchasing and using an RS-232C/422A converter.

Example of Commercially Available Connector :
Network Supply Inc. GPNET232-485CT (Main Unit)
GP-259RS (DOS/ PC 9-Pin Connector), SFN-830 (AC Adapter)

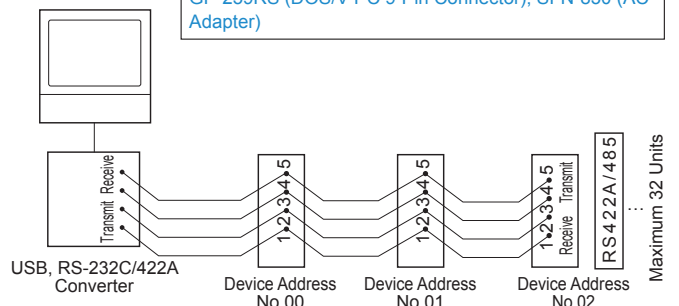

Important Unloading and Placement Information

Ducting Design Points (Air cooled only)

• Ducting Design Points (For User Installed Ducting)

If the area where the unit is to be installed is narrow or has a low ceiling, the ambient temperature could raise to above 45 °C from the heat coming from the ventilation outlet. In such cases, ducting should be used to move the heat outside of the room or at least away from the unit so that the effects of it do not cause the temperature around the unit to rise. Take the following into consideration when planning duct work.

1. Duct cross sectional area

(1) For duct that rises up:

	RKE3750B-V/VL	RKE5500B-V/VL, 7500B-V	RKE11000B1, 15000B-V
Minimum Cross Sectional Area (m ²) [B×W]	0.429	0.611	0.8
Maximum Length (m)	20	20	20

	RKE22000B-V, RKE30000B-V Right Unit	RKE22000B-V, RKE30000B-V Left Unit
Minimum Cross Sectional Area (m ²) [B×W]	0.64	0.64
Maximum Length (m)	20	20

(2) Rectangular ducting with bends:

- The cross sectional area should be greater than above, and Lx and Ly should be less than 2 m. (See Fig. 1.)
- If the length of Lx and Ly go over 2 m, then there should be a 20 cm gap between the hot exhaust air outlet from the unit and a fan should be installed on the duct outlet. Do not allow Lx and Ly to be longer than 5 m. (See Fig. 2.)

► Fig. 1 Examples of Bent Rectangular Ducting

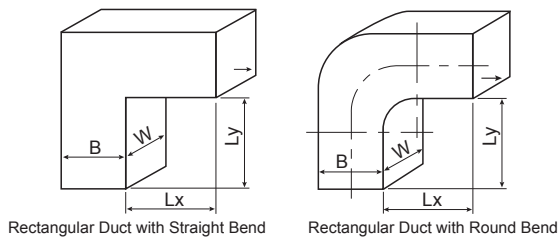

* The duct in the figure is one example. The particular direction the duct exhaust port goes from the unit does not matter, however the following important points must be enforced.

► Fig. 2 : Duct installation method when Lx and Ly exceed 2 m.

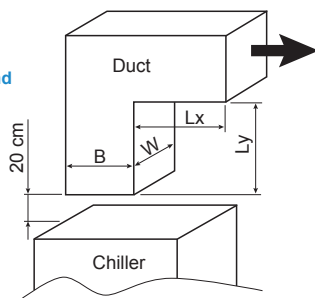

Model	RKE3750B-V/VL	RKE5500B-V/VL, 7500B-V	RKE11000B1, 15000B-V
Recommended Fan	50 Hz power (Mitsubishi Electric Corporation)	EJ-80FTC3 (Mitsubishi Electric Corporation)	EWF-50FTA (Mitsubishi Electric Corporation) × 2
	60 Hz power (Mitsubishi Electric Corporation)	EWG-60FTA (Mitsubishi Electric Corporation)	EWG-50ETA (Mitsubishi Electric Corporation) × 2
Minimum Required Airflow (m ³ /min)	119	186	119 × 2
Model	RKE22000B-V, RKE30000B-V		
Minimum Required Airflow (m ³ /min)	233 × 2		

<IMPORTANT>

Do not have anything such as walls or other obstacles that could obstruct exhaust output within 2 m of the unit in the direction of the duct exhaust output. Failure to follow this rule will result in decreased air flow, the main unit heat ventilation will be insufficient, and built-in safety devices may activate, which would cause unit operation to stop.

• Installing Ducting on the Unit

If ducting is to be affixed to the unit, first remove the suspension eyebolts from the top and replace them with M size bolts of the appropriate size. In this case, install ducting such that at least 500 mm of ducting above the product can be removed when needed in order to allow for easy fan maintenance and inspection.

Model	A	B	C	D	E	M Screw
RKE3750B-V/VL	720	723.5	655	654.6	33.8	M10
RKE5500B-V/VL, 7500B-V	869.5	825.2	804.5	758.6	31.5	M16
RKE11000B1-V	1379	827	1314.2	758.6	33.7	M16
RKE15000B-V	1609	827	1544.2	758.6	33.7	M16
RKE22000, 30000	2113.8	1171	2037	1090.6	41	M24

<IMPORTANT>

Unit : mm

- If ducting is to be affixed directly on the unit, be sure to install support hardware along the ducting in order to prevent the unit from tipping over.

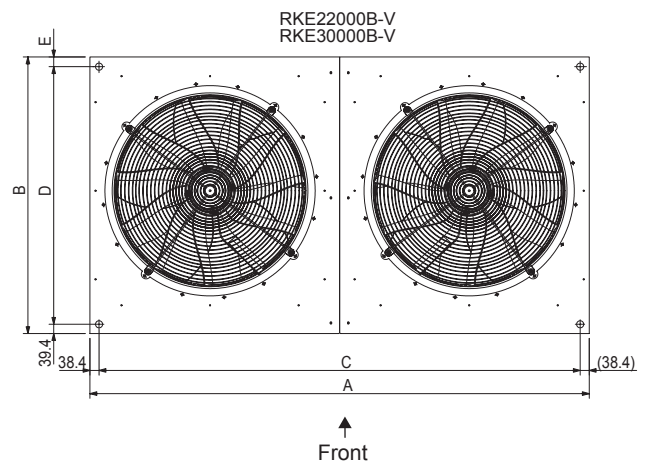
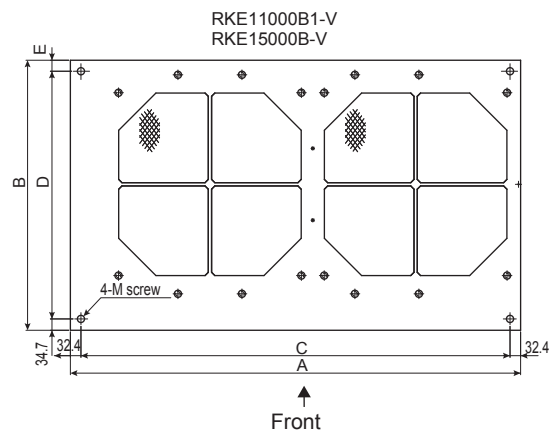
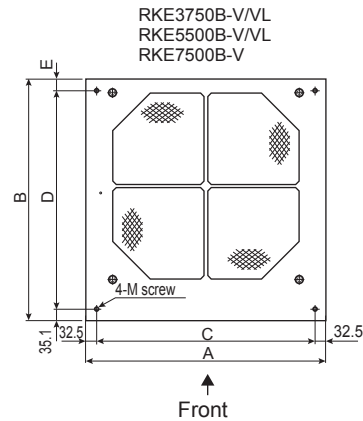

Points to Follow to Achieve Performance Specifications

• Important Points to Ensure Optimum Product Performance

1. Note the operating ranges and always operate the unit within these ranges. Operating outside the designated ranges can lead to unit breakdown.

Clause	RKE3750B-V/VW/VL, 5500B-V/VW/VL, 7500B-V/VW	RKE11000B1, 15000B, 22000B, 30000B-V
Ambient Temp Range (°C)	-20 to 45 (Air cooled) / 2 to 45 (Water cooled)	-20 to 45
Liquid Temp Range (°C)	3 to 35	
Power (V·Hz)	200 to 220 ±10% (50/60 : Air cooled) 200 ±10% (50 : Water cooled), 200 to 220 ±10% (60 : Water cooled)	200 to 220 ±10% (50/60)
Discharge Pump Operating Pressure (Mpa)	0.08 to 0.50	0.08 to 0.80

- Do not use aluminum parts for parts that will be wetted with the chilled water. The unit's water circuits operate with parts made of copper or copper alloys, so if user-installed wetted parts containing aluminum are present, the resulting copper ions will lead to electrolytic corrosion and copper deposits, which can cause water leakage around mechanical seals and clogging in the heat exchanger.
- Please consult your dealer before using any corrosion inhibiting water additives. Troubles such as the water becoming dirty, or damage to the refrigeration unit from clogging etc. can result depending on the type of additive used.
- Always apply power to the unit at least 12 hours before performing initial test runs or after the unit has been unpowered for 24 hours or more. Failure to apply power in advance as directed can lead to damage to the refrigeration compressor.

5. Operating with antifreeze or rust inhibitor additives can reduce the lifespan of the mechanical seals.

<IMPORTANT>

Do not operate with the discharge pump circuit (cooling water inlet/outlet) blocked. Operating the unit with the circuit blocked can result in freezing or damage of the evaporator, breakdown of the discharge pump, disconnection of hoses, or other trouble.

- When using brine for freeze-prevention, use a 30-40% industrial-use ethylene glycol solution. (The cooling capacity will drop approx. 10%.)
- Frequent starting and stopping can lead to unit breakdown. Allow at least 5 minutes between starting and stopping the unit. If the unit is started less than 5 minutes after stopping, warning "C064" or "C065" will be generated.
- Always fill the water tank and check the water level before operating. If the water level gauge goes below the "E" mark, alarm "E006" will occur and the unit cannot be operated.
- The water pressure at the water supply port should be 0.50 MPa or less. Too high pressure will result in the water supply failing to shut off or leakage.
- Always keep the water clean, inspect the water circuits monthly, and replace the water when necessary.
- Clean the condenser filter every month.
- Water cooled: The cooling water should be checked monthly to ensure that it is clean. The water should be changed if dirty.

Chilled Water

• Chilled Water Standards

The recommended liquid (chilled water) that can be used is either clean water (see chart below for water quality standard) or a 30 to 40% ethylene glycol solution. Alternatively, if deionized water is to be used, it should have

	Item	Standard Levels
Standard Components	pH (25 °C)	6.8 – 8.0
	Conductivity (µS/cm) (25 °C)	1 – 400
	Chloride Ion (mgCl ⁻ /L)	Max. 50
	Sulphate (mgSO ₄ ²⁻ /L)	Max. 50
	Acid Consumption (pH 4.8) (mgCaCO ₃ /L)	Max. 50
	Total Hardness (mgCaCO ₃ /L)	Max. 70
	Calcium Hardness (mgCaCO ₃ /L)	Max. 50
	Silica Ion (mgSiO ₂ /L)	Max. 30

an electrical conductivity of at least 1 µS/cm. Cooling non-approved liquid can result in equipment damage, leaking, and possible electric shock or electrical shorts.

	Item	Standard Levels
Reference Components	Iron (mgFe/L)	Max. 1.0
	Copper (mgCu/L)	Max. 1.0
	Sulfide Ion (mgS ²⁻ /L)	Not detected
	Ammonium Ion (mgNH ₄ ⁺ /L)	Max. 1.0
	Residual Chlorine (mgCl/L)	Max. 0.3
	Free Carbon Dioxide (mgCO ₂ /L)	Max. 4.0

* Excerpt from JRA-GL-02-1994 guidelines from The Japan Refrigeration and Air Conditioning Industry Association.

Cooling Water

• Water Selection

Water for the water-cooled condenser may be ground water, municipal water, or cooling-tower water. Refer to the following water quality standard for guidance in selecting the water type.

• Water Quality Standard Guidelines

Primary cooling water (refrigeration unit condenser cooling water, constant temperature water for the water temperature controller, and humidification water) should meet the water quality standard as described in the chart on the right

1. Standard Concentration Levels for Primary Cooling Water

- If tap water is used as the primary cooling water for water cooled equipment, then the water should meet the following water quality standard.
- "○" marks in a tendency column show the factor related to either corrosion or scale generation tendency.
- The 15 items listed to the right are the primary components that can lead to corrosion or scaling.

	Clause	Cooling Water		Tendencies	
		Circulation Water	Supplied Water	Corrosion	Scaling
Standard Items	pH (25 °C)	6.5 to 8.2	6.0 to 8.0	○	○
	Electric Conductivity (µS/cm) (25 °C)	800 or below	300 or below	○	○
	Chloride Ion (mgCl ⁻ /L)	200 or below	50 or below	○	
	Sulfate Ion (mgSO ₄ ²⁻ /L)	200 or below	50 or below	○	
	Acid Consumption (pH4.8) (mgCaC ₂ /L)	100 or below	50 or below		○
	Total Hardness (mgCaCO ₃ /L)	200 or below	70 or below		○
	Calcium Hardness (mgCaCO ₃ /L)	150 or below	50 or below		○
	Ionic Silica (mgSiO ₂ /L)	50 or below	30 or below		○
	Reference Items	Iron (mgFe/L)	1.0 or below	0.3 or below	○
Copper (mgCu/L)		0.3 or below	0.1 or below	○	
Sulfide Ion (mgS ²⁻ /L)		None detected	None detected	○	
Ammonium Ion (mgNH ₄ ⁺ /L)		1.0 or below	0.1 or below	○	
Residual Chlorine (mgCl/L)		0.3 or below	0.3 or below	○	
Free Carbon Dioxide (mgCO ₂ /L)		4.0 or below	4.0 or below	○	
Stability Index		6.0 to 7.0	-	○	○

* Excerpt from JRA-GL-02-1994 guidelines from The Japan Refrigeration and Air Conditioning Industry Association.

Important Unloading and Placement Information RKE-A Series

⚠ WARNING = Failure to follow instructions contained in a WARNING may result in death or serious injury.

⚠ CAUTION = Failure to follow instructions contained in a CAUTION may result in injury to the operator or damage to property.

Pre-Unloading and Unloading Procedures

• Before Unloading

After unpacking, check the nameplate of the unit to ensure it is the correct model ordered. Also, check that the below mentioned included parts are present.

Part Name	Specifications	Qty Per Unit
Y-Strainer	40 mesh equiv., 1.1/4B Model : RKE18000A-V/A-VW	1 pc.
	40 mesh equiv., 2B Model : RKE22000A-VW RKE30000A-VW	1 pc.
Nipple	1.1/4B (To attach the Y-strainer) Model : RKE18000A-V/A-VW	1 pc.
	2B (To attach the Y-strainer) Model : RKE22000A-VW RKE30000A-VW	1 pc.

It is possible that the unit could be damaged during shipping, transport, or other handling. When receiving the unit, check to make sure that there are no scratches or other abnormalities. If any damage or abnormality is detected, please contact the dealer where the unit was purchased.

⚠ WARNING

When making use of the eyebolts, suspend the unit from all 4 eyebolts and make sure there is at least a 60° angle between the top face of the unit and each of the suspension cables. Improper suspension may lead to the unit tipping over or falling, which could result in injury.

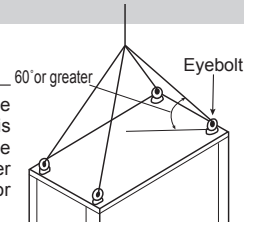

• Unloading Procedure

The unit is heavy; please be careful when transporting it. The unit has rectangular slots at its base in order to accept forklift tines. When lifting the unit by forklift, make sure the forklift tines go through the forklift slots all the way and protrude from the other side of the unit.

Model	Mass (Dry weight)
RKE18000A-V	approx. 660 kg
RKE18000A-VW	610 kg
RKE22000A-VW	approx. 1100 kg
RKE30000A-VW	approx. 1420 kg

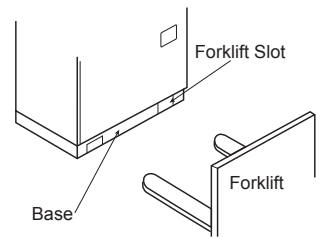

⚠ WARNING

Installation of this equipment should be performed by your dealer or other qualified personnel. Improper installation by the end user may lead to water leakage, electric shock, and fire.

Unit Placement

• Choice of Installation Location

Choose an installation location that is free from combustible materials, areas that could lead to electric shock, or environments that could lead to unit breakdown.

⚠ CAUTION

Install on a level surface that can adequately support the weight of the unit and fix the unit down with anchor bolts to prevent it from moving around. Not properly installing the equipment as indicated can result in water leaks or injury etc., from the unit tipping over or falling.

1. Ensure there is adequate space for heat ventilation as well as sufficient space for maintenance and inspection of the unit. Also note that if the unit is enclosed as in the illustration below, exhaust heat from the unit will be forced back into the unit, causing

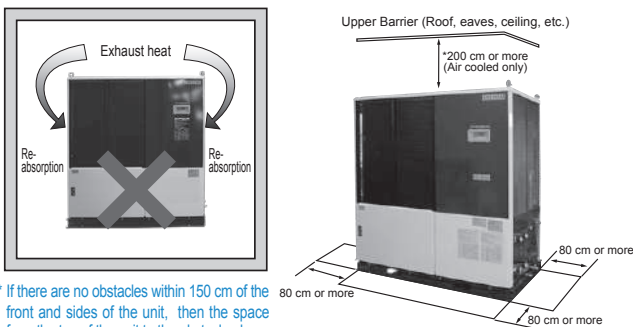

* If there are no obstacles within 150 cm of the front and sides of the unit, then the space from the top of the unit to the obstacle above can be as low as 100 cm or higher.

the refrigerant pressure to rise, and eventually causing the unit to stop.

2. If the unit will be installed where a wind of 8 m/s or higher will be blown on it, measures to block the wind from hitting the unit such as installation of a wind-break panel or wall is required.
3. Install out of direct sunlight and do not install where the unit would be affected by heat. Contact with direct sunlight or heat can cause the unit to perform below specified performance equal to the amount of that exposure. It can also lead to the activation of built-in safety devices which will prevent unit operation.
4. Air cooled: Operate the unit in the ambient temperature of -5 °C – 43 °C. Operating outside this temperature range can lead to breakdown of the compressor. And operating in temperatures over 43 °C will result in a drop in the effectiveness of thermal radiation of the condenser. Built-in safety devices may activate causing the unit to shut down. If the ambient temperature will be above 43 °C, install ducting, following the section on page 86, "Ducting Design Points".
Water cooled: Operate the unit in the ambient temperature of 2 °C – 43 °C. Operating outside this temperature range can lead to breakdown of the compressor.

When performing ductwork, install such that the ducting is not constricted along the way. Failure to follow this rule can also lead to activation of built-in safety devices which will stop unit operation.

5. Install in a place that is generally free of dust and dirt. Installation in places with heavy dust and dirt can result in reduction of unit performance.
6. Note that operating air-cooled models solely in the Snow-Protection Mode in areas that heavy snowfall will result in reduced performance. It is therefore recommended that the unit be installed away from falling snow. (Air cooled only)
7. Operate the product at a cooling water temperature within the range of 5 °C to 34 °C. If operated outside the specified range, the safety device will be activated to shutdown the product. It can also cause the compressor to malfunction. (Water cooled only)

Model	Air Cooled		Water Cooled	
	RKE18000A-V	RKE18000A-VW	RKE22000A-VW	RKE30000A-VW
Maint. & Insp. Space (cm)	Front	80 or more	100 or more	
	Side	80 or more	100 or more	
	Back	10 or more	-	
	Top	200 or more	-	
Ambient Temp (°C)	-5 to 43		2 to 43	
Cooling Water Temp (°C)	-		5 to 34	

Water Supply and Drainage Construction

- Reliably install water supply and drainage piping. Improper water supply and drainage construction could result in water spraying out, causing water damage to the surrounding area.
- Keep water supply pressure at or below 0.50 MPa. Too high pressure can lead to equipment damage, which may lead to water leaks, flooding of the surrounding area, and electric shock.
- Keep the cooling water pressure below 0.69 MPa. Higher pressure may damage the components to cause water leakage and may result in electric shock.

- When performing water piping, be careful to avoid the following points. Failure to do so can result in water leakage.

1. Overtightening the piping connected to the water supply port.
2. Having external forces on the water supply port.
3. Piping installation that does not absorb vibrations of water hammer, etc.

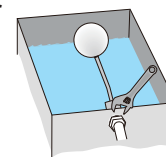

- When connecting piping to the water supply port, always use two tools, using one to support the ball tap valve, as shown in the illustration to the right.

Chilled Water / Cooling Water Piping

Piping Sizes

Piping diameters for each model are listed below.

Piping Item	Piping Size			
	RKE18000A-V	RKE18000A-VW	RKE22000A-VW	RKE30000A-VW
Chilled Water Inlet	Rc1.1/4		Rc2	
Chilled Water Outlet	Rc1.1/4		Rc2	
Water Tank Drain	Rc3/4			Rc1
Overflow	Rp1			
Drain Pan Drain Port	Rc1/2		Rc1/2, 3 locations	
Water Supply Port	Rp1/2			
Cooling Water Piping Inlet	-	Rc1.1/2	Rc2	
Cooling Water Piping Outlet	-	Rc1.1/2	Rc2	

Piping Methods

Piping installation should follow the guidelines below.

1. Check the chilled water inlet and outlet ports.
2. Make pipe lengths as short as possible, and also avoid vertical and curved piping as much as possible.
3. When tightening overflow piping connections, use 2 pipe wrenches or adjustable wrenches in order to grasp both sides of the joint.
4. Always install valves (customer supplied) at the chilled water inlet and outlet ports.
5. Install the included Y-strainer on the chilled water intake side port.
6. Make sure that there is no excessive weight or vibration directed on the unit from the connected piping. Long horizontal piping should be supported with additional support hardware to ensure unreasonable forces are not applied directly to the unit's connection ports. Failure to properly support piping can lead to equipment damage.
7. Piping should be insulated. (Install the pipe insulation such that there is enough gap to allow the removal of the cabinet water supply port.)
8. If an automatic water supply system is to be installed, be sure to install a valve on the supply port. Also, keep water supply pressure at or below 0.50 MPa.
9. Always support water supply piping with support fittings, and make sure that piping is horizontal.

Pipe Connection Procedure (Water cooled)

1. Confirm the positions of the Cooling Water inlet and outlet. The Cooling Water inlet and outlet are specified with stickers.
2. Follow the instructions below for piping work.
 - (1) Mount the Cooling Water inlet valve <1> and the Cooling Water outlet valve <2>.
 - (2) Be sure to mount the safety relief valve <3>. The regulating valve that is installed in the cooling water circuit performs the opening and closing of the valve automatically by detecting the refrigerant pressure. Thus, there is a possibility that the regulating valve becomes full-closed during operation. Be sure to install the safety relief valve for the water leakage prevention in the cooling water circuit, and set the cooling water inlet pressure 0.69 MPa or lower.
 - (3) Install the purge/drain valve <4>.
 - (4) Be sure to install the union coupling <5>. Make sure that the product and the cooling water piping can be easily disassembled when carrying out the cleaning of water-cooled condenser inside the product.

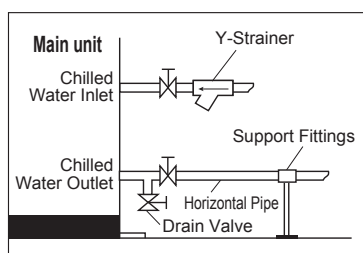
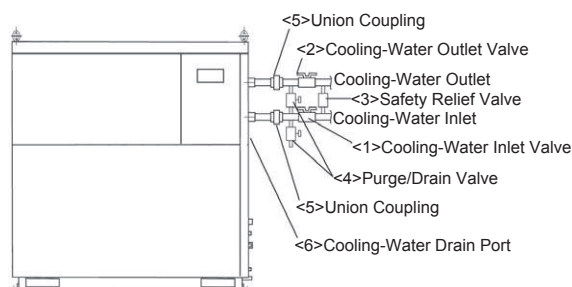

Important Unloading and Placement Information

Electrical Wiring

• Correct Wiring Installation

When performing electrical wiring, be sure to carefully follow the guidelines listed below.

* Photo below shows the piping arrangement of model RKE18000A-V.

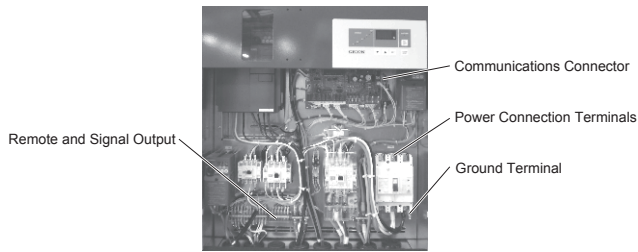

1. Choose a power cable based on the breaker capacity shown in the table to the right. Hook up the ground wire to the earth (ground) terminal located in the distribution box. Also, regarding the power and signal terminal block, refer to the chart on the right for the screw size and terminal block width.
2. Route the power cord through the power cord access hole, located on the lower-right part of the unit, to the inside of the terminal box. (Use 1 of the 2 available power cord access holes. The other can be used for remote control panel connections, etc.) Connect the power cord to the L1, L2,

and L3 terminals on the terminal block. Fix the power cord in place with a cable tie.

3. Always properly ground this unit. Connect the ground wire to a proper earth/ground point that has been installed by a qualified electrician. Furthermore, the diameter of the grounding wire must be at least 2 mm².
- * Prepare the ground wire terminal of a size according to the screw size listed in the chart to the right.
4. Ensure the source voltage is within ±10% of the specified voltage. Also make sure the source voltage phase unbalance is within ±3%.
- * Phase unbalance (%) = (Maximum voltage [V] - Minimum voltage [V]) ÷ Average voltage of 3 phases (V) × 67. (Based on IEC61800-3.)

<IMPORTANT>

- Make sure the power cord does not come into contact with the refrigerant piping or any motor within the unit. Contact with hot surfaces could cause the cord to melt, resulting in an electrical short. (Secure the power cable with the cable tie inside the distribution box.)
- Never operate the unit when the water circuit is empty. Always fill the water tank and confirm the water level before operating.
- Do not attempt to perform withstand voltage tests or insulation resistance tests. Doing so can damage the semiconductors used in the chiller control board or inverter. If the tests are deemed necessary, please consult with your dealer.

Item		RKE18000A-V	RKE18000A-VW	RKE22000A-VW	RKE30000A-VW
Power Source (V•Hz)		Three-phase 200 V, 50/60 Hz; three-phase 220 V, 60 Hz			
Terminal Block	Screw size	Power	M8		
		Signal	M3.5		
	Terminal Block Width (mm)	Power	23		
		Signal	7.5		
Breaker Capacity (A)		125			175
Current Sensitivity (mA)			100		
Ground Terminal		M6			M8
Ground Terminal (mm ²)			2 or more		

If Employing Remote Control Operation

• Information Regarding Remote Operation and Communications Functions

Perform the wiring after confirming the required specifications. * Please prepare terminals that fit M3 size screws.

1. Please confirm the unit specifications which are as follows.

Remote Operation Input Specifications	<ul style="list-style-type: none"> • No-voltage contacts input (alternate switch) • Maximum cable length: 20 m • Input resistance: 1200 Ω • Open circuit voltage (Voc): 12 Vdc • Short circuit current (Isc): 10 mA DC
Signal Output Specifications	<ul style="list-style-type: none"> • Relay output (a contact) • 250 VAC / 30 VDC, 3 A (resistance load) (normally closed) • Minimum operating current (for reference only) 5 VDC, 10 mA

2. Remote operation and signal output terminals are as follows:

	Remote Operation
Remote Operation Contacts	
Signal Output Contacts	13 Operation Signal (Closed during operation)
	15 Alarm Signal (Closed during alarm condition)
	16

• When Using Communications Functions

RS-232C	Connector: D sub 9 pin female connector Comm. cable max. length: 15 m. * May differ depending on specific operating conditions.
---------	---

RS-422A (RS-485)	Terminal Block Comm. Cable Size: AWG 16 to 24 * If inserting 2 wires into one location on the terminal block: AWG 18 to 24 * Length of insulation to remove: 10 mm Max. comm. cable length: 100 m. (From host to the end-unit) * May differ depending on specific operating conditions.
------------------	---

• Communication Protocol

ORION Protocol

Ducting Design Points (Air cooled only)

• Ducting Design Points (For User Installed Ducting)

If the area where the unit is to be installed is narrow or has a low ceiling, the ambient temperature could raise to above 43 °C from the heat coming from the ventilation outlet. In such cases, ducting should be used to move the heat outside of the room or at least away from the unit so that the effects of it do not cause the temperature around the unit to rise. Take the following into consideration when planning duct work.

1. Duct cross sectional area

(1) For duct that rises up:

Model		RKE18000A-V
Min. Cross Sectional Area (m ²) [B×W]		0.519
Max. Length (m)		20
Recommended Fan	50 Hz Power	EWF-60FTB (Mitsubishi Elec. Co.) × 2
	60 Hz Power	
Min. Req. Air Flow (m ³ /min)		186 × 2

(2) Rectangular ducting with bends:

- The cross sectional area should be greater than above, and Lx and Ly should be less than 2 m. (See Fig. 1.)
- If the length of Lx and Ly go over 2 m, then there should be a 20 cm gap between the hot exhaust air outlet from the unit and a fan should be installed on the duct outlet. Do not allow Lx and Ly to be longer than 5 m. (See Fig. 2.)

* The duct in the figure is one example. The particular direction the duct exhaust port goes from the unit does not matter, however the following important points must be enforced.

▶ Fig. 1 Examples of bent rectangular ducting.

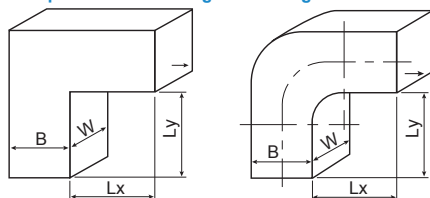

• Installing Ducting on the Unit

If ducting is to be installed directly onto the product, then use the duct mounting holes located at the top of the product. In such cases, in order to allow for easy fan maintenance and inspection, provide for at least 500 mm of space above the product to allow for removal of the ducting.

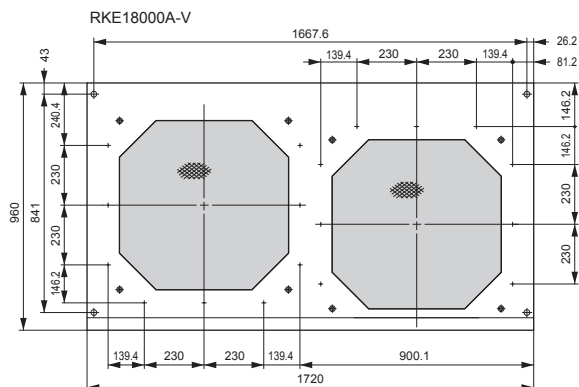

<IMPORTANT>

Do not have anything such as walls or other obstacles that could obstruct exhaust output within 2 m of the unit in the direction of the duct exhaust output. Failure to follow this rule will result in decreased air flow, the main unit heat ventilation will be insufficient, and built-in safety devices may activate, which would cause unit operation to stop.

▶ Fig. 2 : Duct installation method when Lx and Ly exceed 2 m.

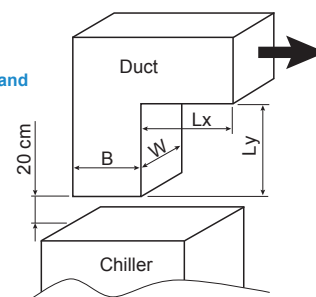

<IMPORTANT>

- If ducting is to be affixed directly on the unit, be sure to install support hardware along the ducting in order to prevent the unit from tipping over.

Important Unloading and Placement Information

Points to Follow to Achieve Performance Specifications

• Important Points to Ensure Optimum Product Performance

1. Note the operating ranges and always operate the unit within these ranges. Operating outside the designated ranges can lead to unit breakdown.

Item	RKE18000A-V	RKE18000A-VW	RKE22000A-VW	RKE30000A-VW
Operable Ambient Temp Range (°C)	-5 to 43		2 to 43	
Operable Liquid Temp Range (°C)		5 to 35		15 to 30
Power (V•Hz)	Three-phase 200 ±10% (50/60), three-phase 220 ±10% (60)			
Discharge Pump Operating Pressure (MPa)	0.5 or lower			

- Do not use aluminum parts for parts that will be wetted with the chilled water. The unit's water circuits operate with parts made of copper or copper alloys, so if user-installed wetted parts containing aluminum are present, the resulting copper ions will lead to electrolytic corrosion and copper deposits, which can cause water leakage around mechanical seals and clogging in the heat exchanger.
- Please consult your dealer before using any corrosion inhibiting water additives. Troubles such as the water becoming dirty, or damage to the refrigeration unit from clogging etc. can result depending on the type of additive used.
- Always apply power to the unit at least 12 hours before performing initial test runs or after the unit has been unpowered for 24 hours or more. Failure to apply power in advance as directed can lead to damage to the refrigeration compressor.
- Operating with antifreeze rust inhibitor additives can reduce the lifespan of the mechanical seals.

<IMPORTANT>

Do not operate with the discharge pump circuit (cooling water inlet/outlet) blocked. Operating the unit with the circuit blocked can result in freezing or damage of the evaporator, breakdown of the discharge pump, disconnection of hoses, or other trouble.

- When using brine for freeze-prevention, use a 30-40% industrial-use ethylene glycol solution. (The cooling capacity will drop approx. 10%.)
- Frequent starting and stopping can lead to unit breakdown. Allow at least 5 minutes between starting and stopping the unit. If the unit is started less than 5 minutes after stopping, warning "C064" or "C065" will be generated.
- Always fill the water tank and check the water level before operating. If the water level gauge goes below the "E" mark, alarm "E006" will occur and the unit cannot be operated.
- The water pressure at the water supply port should be 0.50 MPa or less. Too high pressure will result in the water supply failing to shut off or leakage.
- Always keep the water clean, inspect the water circuits monthly, and replace the water when necessary.
- Clean the condenser filter every month.
- Water cooled: The cooling water should be checked monthly to ensure that it is clean. The water should be changed if dirty.

Chilled Water

• Chilled Water Standards

The recommended liquid (chilled water) that can be used is either clean water (see chart below for water quality standard) or a 30 to 40% ethylene glycol solution. Alternatively, if deionized water is to be used, it should have

Item	Standard Levels
pH (25 °C)	6.8 – 8.0
Conductivity (µS/cm) (25 °C)	1 – 400
Chloride Ion (mgCl ⁻ /L)	Max. 50
Sulphate (mgSO ₄ ²⁻ /L)	Max. 50
Acid Consumption (pH 4.8) (mgCaCO ₃ /L)	Max. 50
Total Hardness (mgCaCO ₃ /L)	Max. 70
Calcium Hardness (mgCaCO ₃ /L)	Max. 50
Silica Ion (mgSiO ₂ /L)	Max. 30

an electrical conductivity of at least 1 µS/cm. Cooling non-approved liquid can result in equipment damage, leaking, and possible electric shock or electrical shorts.

Item	Standard Levels
Iron (mgFe/L)	Max. 1.0
Copper (mgCu/L)	Max. 1.0
Sulfide Ion (mgS ²⁻ /L)	Not detected
Ammonium Ion (mgNH ₄ ⁺ /L)	Max. 1.0
Residual Chlorine (mgCl/L)	Max. 0.3
Free Carbon Dioxide (mgCO ₂ /L)	Max. 4.0

* Excerpt from JRA-GL-02-1994 guidelines from The Japan Refrigeration and Air Conditioning Industry Association.

Cooling Water

• Water Selection

Water for the water-cooled condenser may be ground water, municipal water, or cooling-tower water. Refer to the following water quality standard for guidance in selecting the water type.

• Water Quality Standard Guidelines

Primary cooling water (refrigeration unit condenser cooling water, constant temperature water for the water temperature controller, and humidification water) should meet the water quality standard as described in the chart on the right

1. Standard Concentration Levels for Primary Cooling Water

- If tap water is used as the primary cooling water for water cooled equipment, then the water should meet the following water quality standard.
- "o" marks in a tendency column show the factor related to either corrosion or scale generation tendency.
- The 15 items listed to the right are the primary components that can lead to corrosion or scaling.

Clause	Cooling Water		Tendencies			
	Circulation Water	Supplied Water	Corrosion	Scaling		
Standard Items	pH (25 °C)	6.5 to 8.2	6.0 to 8.0	o	o	
	Electric Conductivity (µS/cm) (25 °C)	800 or below	300 or below	o	o	
	Chloride Ion (mgCl ⁻ /L)	200 or below	50 or below	o	o	
	Sulfate Ion (mgSO ₄ ²⁻ /L)	200 or below	50 or below	o	o	
	Acid Consumption (pH4.8) (mgCaC ₃ /L)	100 or below	50 or below		o	
	Total Hardness (mgCaCO ₃ /L)	200 or below	70 or below		o	
	Calcium Hardness (mgCaCO ₃ /L)	150 or below	50 or below		o	
	Ionic Silica (mgSiO ₂ /L)	50 or below	30 or below		o	
	Reference Items	Iron (mgFe/L)	1.0 or below	0.3 or below	o	o
		Copper (mgCu/L)	0.3 or below	0.1 or below	o	o
		Sulfide Ion (mgS ²⁻ /L)	None detected	None detected	o	o
		Ammonium Ion (mgNH ₄ ⁺ /L)	1.0 or below	0.1 or below	o	o
		Residual Chlorine (mgCl/L)	0.3 or below	0.3 or below	o	o
		Free Carbon Dioxide (mgCO ₂ /L)	4.0 or below	4.0 or below	o	o
		Stability index	6.0 to 7.0	-	o	o

* Excerpt from JRA-GL-02-1994 guidelines from The Japan Refrigeration and Air Conditioning Industry Association.

Working Principles and Model Configurations

Working principles -- Diagrams

■ With Built-In Water Tank (Closed loop)

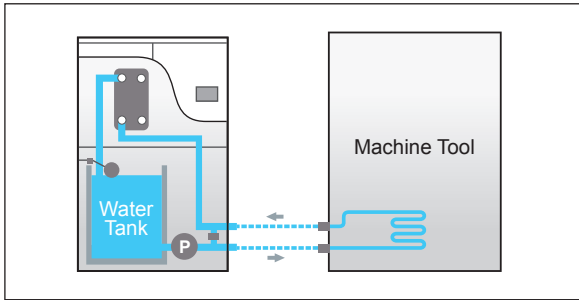

Working Principles

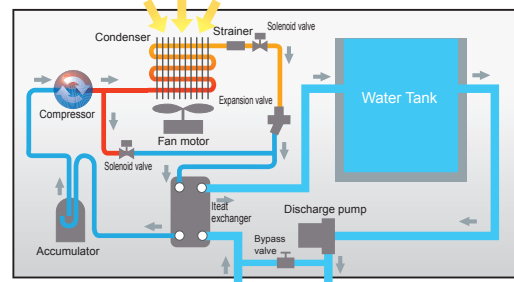

The pump built into the unit pumps liquid from the water tank and then through the heat exchanger. There, the liquid is cooled and then returns to the tank. This cycle is repeated and the liquid is continuously cooled until it reaches the desired set temperature, at which time the temperature regulator shuts off the chiller. And if the liquid temperature rises above the set control value, the chiller is automatically started again. In this way, the liquid temperature is maintained and the liquid is pumped out via the discharge pump.

* In addition to the discharge pump, some models are equipped with built-in circulation pumps. Please refer to individual model specifications for further details.

* The above image is for illustrative purpose only. Please refer to individual model specifications for further details.

Making the Right Model Choice

Sample cooling load calculation and model selection methods are listed below.

Please make a model choice that best suits your operating conditions and requirements.

Example 1

Find the cooling capacity required to deal with heat generated by a piece of equipment which is to be cooled by a chilled water flow.

The equipment to be cooled is accepting a cooling water flow of 12 L/min, the water temperature going into the equipment is 17 °C, and the temperature of the water coming out is 20 °C. What is the amount of heat being generated by this equipment?

$$Q = \frac{(t_2 - t_1) \times X \times C \times \rho}{60} = \frac{(20 - 17) \times 12 \times 4.2 \times 1}{60} \doteq 2.5 \text{ kJ/s} = 2.5 \text{ kW}$$

Note: When making a model selection, also consider heat from external sources that might raise the water temperature. In order to compensate for such external heat sources, it is recommended that an additional 20% in cooling capacity be added to the calculation.

$$Q = 2.5 \times 1.2 = 3.0 \text{ kW}$$

Example 2

In case a certain temperature drop is required in a fixed amount of time.

For example, if 40 L of 20 °C water is in a separate tank, what is the heat dissipation required to lower the temperature of the water to 5 °C in one hour?

$$Q = \frac{W \times C \times (t_2 - t_1)}{H} = \frac{40 \times 4.2 \times (20 - 5)}{3600} = 0.7 \text{ kJ/s} = 0.7 \text{ kW}$$

Note: When making a model selection, also consider heat from external sources that might raise the water temperature. In order to compensate for such external heat sources, it is recommended that an additional 20% in cooling capacity be added to the calculation.

$$Q = 0.7 \times 1.2 = 0.84 \text{ kW}$$

Q: Amount of heat in kW (kW = kJ/s)

W: Weight of liquid to be cooled in kg (volume (L) x specific gravity)

ρ: Specific gravity (kg/L, 1 in case of water)

C: Specific heat (kJ/kg°C, 4.2 in case of water)

t₂: Upper temperature (°C)

t₁: Lower temperature (°C)

H: Required cooling time in second

X: Water flow per minute (L/min)

Introducing the ORION IoT System

Remote Monitoring & Remote Operation of ORION Products.

Uses your factory's internal network for safety against leaks of internal information.

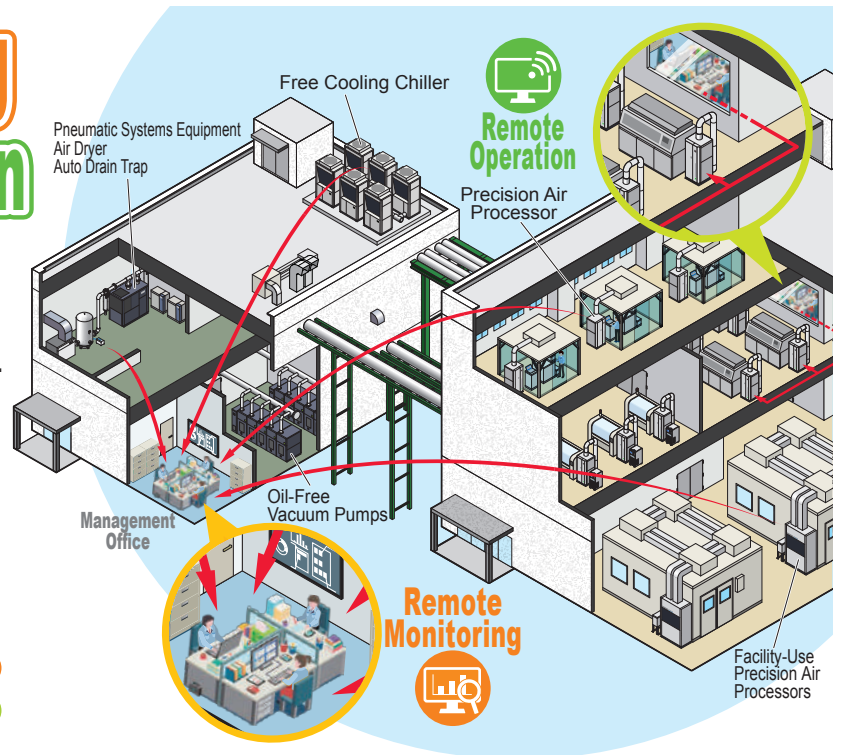

Compatible Models

RKE-C Series



Monitoring
Communication

RKE-B Series



Monitoring
Data Collection
Communication

RKE-A Series



Monitoring
Communication



Contact-State Monitoring Software

Includes Mail-Alert Functionality

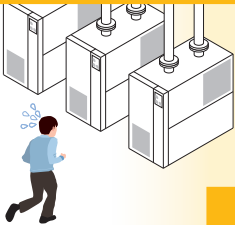

Need to walk to the site every day in order to check the operating state of your equipment...

And the constant worry that you won't be around when an alarm condition occurs!

Monitoring of product operating states from remote sites is possible. Can be used as long as contact outputs are non-voltage contacts. Get email alerts when alarms occur! Getting alerts while away from the PC gives peace of mind!

Checking operating states is easy! Mail alerts for alarm conditions give peace-of-mind when away from the site.



Operation Data Acquisition Software

Includes Mail-Alert Functionality

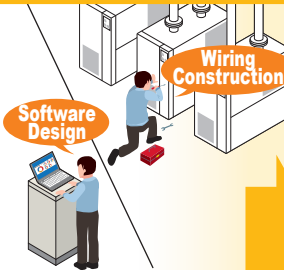

We need to design wiring and specialized software to enable data logging product operating-states and operating conditions...

Can perform CSV-format logging of product operation status. Data can be graphed using our free downloadable software that is easy and safe, even for beginners!

Data can be viewed from other PCs or tablets through the Internet.



ORION Communication Software

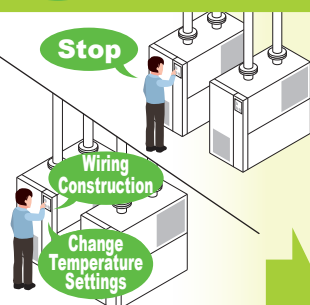

Need to walk to the factory each time to start and stop operation...

Run/Stop operations are possible from remote locations. And temperature settings can also be changed.

Now, Run/Stop and other operations are easier!



How to Download our IoT Software

STEP 1

Visit our website.



STEP 2

Confirm the download you need from the list of software.

STEP 3

Perform the registration process and enter the product model number and serial number.

Note that our software is only offered in Japanese. Operation with non-Japanese operating systems has not been confirmed. Please refer to the instruction manual for required equipment and specifications.

ORION Offers a Wide-ranging Product Lineup

Compact Non-fluorocarbon Inverter Chiller with Water Tank

R1234yf is a non-fluorocarbon gas and therefore is not targeted under the “Fluorocarbon Emission Reduction Law” and, as such, does not require qualified technicians to perform collection or periodic inspections, which means reduced costs associated with fluorocarbon-related management and disposal.

Specifications

Cooling Capacity: 3.3 / 6.1 kW
Refrigerant: R1234yf
Temperature Control: ± 0.1



Compact Chillers with Built-in Water Tanks

Our 3-model lineup includes high spec., mid-grade, and economy models. Chose the chiller that meets your price and operating requirements from 3 models.

Specifications

Cooling Capacity(50/60Hz) : 1.3 / 1.5 to 9.5 kW
Refrigerant: R410A
Temperature Control: $\pm 0.1^{\circ}\text{C}$ ($\pm 2.0^{\circ}\text{C}$ for RKS-J Series models)



Energy Saving Precision Air Processor

Combining Energy Savings and High Precision.
Capacity Control from the Industry Leader in Heat Pump Balance Control

Specifications

Air Processing Capacity: 3 to 40 m³/min (PAP),
0.7 to 4 m³/min (PAP mini)
Temperature Setting Range: 18 to 30 °C
Temperature Control Precision: $\pm 0.1^{\circ}\text{C}$



Energy Saving Dry Room System

Integrated Unit Provides for an Easy, Ultra-Low Humidity Space. Perfect for experimentation and research applications!

Specifications

Air Processing Capacity: 0.5 to 1.5 m³/min (DPU01A),
1.0 to 2.5 m³/min (DPU02A)
Temperature Setting Range: 23 to 27 °C (DPU02A only)
Temperature Control Precision: $\pm 0.5^{\circ}\text{C}$ (DPU02A only)





Orion Products -- Service and Safety

● Safety Notes

- Before operating this equipment, please read the operating manual carefully, and only use as indicated.
- For installation of this equipment and required wiring, employ a qualified person or consult with your dealer.
- Be sure to select equipment which suits your needs. Do not use this equipment for purposes other than those for which it is intended. Doing so can lead to accidents or equipment breakdown.

● Air-Cooled Models

If the condenser becomes clogged with dust or dirt, heat exchange will be greatly reduced and electricity consumption will increase. This will lead not only to decreased performance, but can also lead to the activation of built-in safety devices, and eventual damage to the equipment. For these reasons, the condenser should be cleaned on a regular basis.

● Water-Cooled Models

In general, water used to cool condensers will be well-water, tap water, or water from a cooling tower. However water of insufficient quality can lead to scaling in cooling pipes resulting in lower levels of heat exchange, increased electricity consumption and lower performance. Therefore water quality should be confirmed on a regular basis.

Regarding After-Service

- For information regarding repair of equipment that has been in operation, please consult your dealer.
- The customer will be responsible for charges incurred for repairs conducted after the warranty period has expired. In cases where equipment function can be improved by certain service procedures, such procedures will be taken at the specific request of the customer.
- Regarding spare parts... "Spare parts" are those which are necessary in order to maintain the function of the product. It is the policy of ORION to maintain a stock of replacement parts for 7 years after production of the product ceases.

Recommended Maintenance Inspections

- Depending on the particular item, extended use can lead to the product becoming dirty or worn, which can lead to decreased performance. In order to realize continued best performance of this equipment, in addition to prescribed customer maintenance, it is also recommended that regular inspections be conducted. (Service and inspection fees apply.) For further information please consult your dealer or contact ORION directly.

Refrigerant Management

Some of the products in this catalog contain HFC refrigerants. Refrigeration technologies that use HFC refrigerants are essential for achieving efficient temperature control, and while such technologies make great contributions toward saving energy, there is also concern of the impact that the accidental release of HFC refrigerants into the atmosphere has on global warming.

When dealing with HFCs, please ensure compliance with laws and regulations and be sure to manage them appropriately for your safety and for the protection of the environment.

●GWP Values of Refrigerants Used in Our Products

Refrigerant	Global Warming Potential (100-year GWP)
R134a	1430
R404A	3920
R407C	1770
R410A	2090
R32	675

* For details about the refrigerant used in specific products, please refer to the product's specification page.

ORION is continuing to develop a complete and trustworthy nationwide network of expedient sales and service -- everywhere, anytime.



*ORION has wide reaching regional service bases in various countries throughout the world. Please consult your ORION dealer for details.



For inquiries, please contact the following representative:

Distributed by:



+62 811 8754 185

www.kobelindo.co.id

ORION MACHINERY CO.,LTD.

International Group 246, Kotaka, Suzaka-shi, Nagano-ken, 382-8502 Japan
TEL +81-(0)26-246-5664 FAX +81-(0)26-246-5022
Email: kokusai@orionkikai.co.jp

Head Office & Factory 246, Kotaka, Suzaka-shi, Nagano-ken, 382-8502 Japan
TEL +81-(0)26-245-1230 FAX +81-(0)26-245-5424
URL: <http://www.orionkikai.co.jp>

This catalog contains product specifications as of March, 2024.

- Actual product colors may vary slightly from the pictures.
- Please note that the structure or specifications of products contained in this catalog are subject to change without prior notice.